

Air Cooled screw chiller



EWAD~T-B

T-SS (Standard Efficiency - Standard Noise) - Cooling Capacity from 290 to 2148 kW
T-SL (Standard Efficiency - Low Noise) - Cooling Capacity from 290 to 2148 kW
T-SR (Standard Efficiency - Reduced Noise) - Cooling Capacity from 685 to 2077 kW
T-XS (High Efficiency - Standard Noise) - Cooling Capacity from 351 to 2087 kW
T-XL (High Efficiency - Low Noise) - Cooling Capacity from 351 to 2087 kW
T-XR (High Efficiency - Reduced Noise) - Cooling Capacity from 694 to 2024 kW

Performance according to EN14511.



www.eurovent-certification.com

Low operating cost and extended operating life. EWAD~T -B chiller range is the result of careful design, aimed to optimize the energy efficiency of the chillers, with the objective of bringing down operating costs and improving installation profitability, effectiveness and economical management. The chillers feature a high efficiency single screw compressor design, large condenser coil surface area for maximum heat transfer and low discharge pressure, advanced technology condenser fans and a ‘shell&tube’ evaporator with low refrigerant pressure drops.

Low operating sound levels Very low sound levels both at full load and part load conditions are achieved by the latest compressor design and by a unique new fan that moves large volume of air at exceptionally low sound levels and by the virtually vibration -free operation.

Outstanding reliability The chillers have two truly independent refrigerant circuits, in order to assure maximum safety for any maintenance, whether planned or not. They are equipped with a rugged compressor design with advanced composite compressor gate rotors material, a proactive control logic and are full factory - run-tested to optimized trouble -free operation.

Infinite capacity control Cooling capacity control is infinitely variable by means of a single screw asymmetric compressor controlled by microprocessor system. Each unit has infinitely variable capacity control from 100% down to 12,5%. This modulation allows the compressor capacity to exactly match the building cooling load without any leaving evaporator water temperature fluctuation:

With a compressor load step control in fact, the compressor capacity, at partial loads, will be too high or too low compared to the building cooling load. The result is an increase in chiller energy costs, particularly at the part-load conditions at which the chiller operates most of the time.

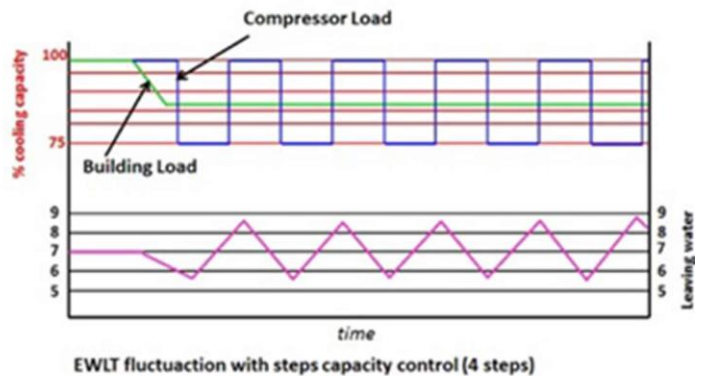

Units with stepless regulation offer benefits that the units with step regulation are unable to match. The ability to follow the system energy demand at any time and the possibility to provide steady outlet water temperature without deviations from the set-point, are the two points that allow you to understand how the optimum operating conditions of a system can be met through the use of a unit with stepless regulation.

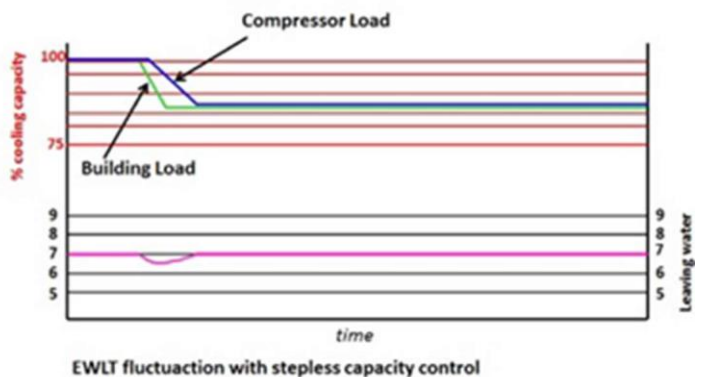

Superior control logic The MicroTech III controller provides an easy to use control environmental. The control logic is designed to provide maximum efficiency, to continue operation in unusual operating conditions and to provide a history of unit operation. One of the greatest benefits is the easy interface with LonWorks, Bacnet, Ethernet TCP/IP or Modbus communications. Master/Slave operation is provided as standard allowing to connect up to 4 units working as a single bigger chiller.

Code requirements – Safety and observant of laws/directives Units are designed and manufactured in accordance with applicable selections of the following:

Construction of pressure vessel	2014/68/EU
Machinery Directive	2006/42/EU
Low Voltage	2014/35/EU
Electromagnetic Compatibility	2014/30/EU
Electrical & Safety codes	EN 60204-1 / EN 60335-2-40
Manufacturing & Quality Standards	UNI EN ISO 1400

Certifications Units are CE marked, complying with European directives in force, concerning manufacturing and safety. On request units can be produced complying with laws in force in non European countries (ASME, GOST, etc.), and with other applications, such as naval (RINA, etc.).

Additional information related to F-GAS Regulation (EU) No 517/2014 of the European Parliament and of the Council of 16 April 2014 on fluorinated greenhouse gases and repealing Regulation (EC) No 842/2006

- **Double circuits**

Unit model	Refrigerant type	Refrigerant GWP	No. of circuits	Refrigerant charge circuit 1 (kg)	Refrigerant charge circuit 1 (TCO2Eq)	Refrigerant charge circuit 2 (kg)	Refrigerant charge circuit 2 (TCO2Eq)
EWAD290T-SS/SL B2	R134a	1430	2	17	24	33	47
EWAD330T-SS/SL B2	R134a	1430	2	17	24	33	47
EWAD370T-SS/SL B2	R134a	1430	2	28	40	28	40
EWAD400T-SS/SL B2	R134a	1430	2	28	40	28	40
EWAD430T-SS/SL B2	R134a	1430	2	29	41	29	41
EWAD510T-SS/SL B2	R134a	1430	2	29	41	29	41
EWAD520T-SS/SL B2	R134a	1430	2	26	37	40	57
EWAD580T-SS/SL B2	R134a	1430	2	27	39	40	57
EWAD700T-SS/SL/SR B2	R134a	1430	2	47	67	47	67
EWAD800T-SS/SL/SR B2	R134a	1430	2	47	67	47	67
EWAD940T-SS/SL/SR B2	R134a	1430	2	78	111	31	44
EWADC10T-SS/SL/SR B2	R134a	1430	2	78	111	31	44
EWADH10T-SS/SL/SR B2	R134a	1430	2	62	89	47	67
EWADC11T-SS/SL/SR B2	R134a	1430	2	78	111	47	67
EWADH12T-SS/SL/SR B2	R134a	1430	2	62	89	62	89
EWADH13T-SS/SL/SR B2	R134a	1430	2	78	111	62	89
EWADH14T-SS/SL/SR B2	R134a	1430	2	78	111	78	111
EWAD350T-XS/XL B2	R134a	1430	2	26	37	26	37
EWAD380T-XS/XL B2	R134a	1430	2	27	39	27	39
EWAD400T-XS/XL B2	R134a	1430	2	26	37	39	56
EWAD420T-XS/XL B2	R134a	1430	2	26	37	40	57
EWAD440T-XS/XL B2	R134a	1430	2	26	37	40	57
EWAD490T-XS/XL B2	R134a	1430	2	26	37	40	57
EWAD540T-XS/XL B2	R134a	1430	2	36	51	36	51
EWAD570T-XS/XL B2	R134a	1430	2	36	51	36	51
EWAD730T-XS/XL/XR B2	R134a	1430	2	47	67	47	67
EWAD820T-XS/XL/XR B2	R134a	1430	2	47	67	47	67
EWAD950T-XS/XL/XR B2	R134a	1430	2	78	111	47	67
EWADC10T-XS/XL/XR B2	R134a	1430	2	94	134	31	44
EWADH10T-XS/XL/XR B2	R134a	1430	2	78	111	62	89
EWADH11T-XS/XL/XR B2	R134a	1430	2	94	134	62	89
EWADC13T-XS/XL/XR B2	R134a	1430	2	78	111	78	111
EWADH13T-XS/XL/XR B2	R134a	1430	2	94	134	78	111
EWADC14T-XS/XL/XR B2	R134a	1430	2	94	134	78	111

• **Triple circuits**

Unit model	Refrigerant type	Refrigerant GWP	No. of circuits	Refrigerant charge circuit 1 (kg)	Refrigerant charge circuit 1 (TCO2Eq)	Refrigerant charge circuit 2 (kg)	Refrigerant charge circuit 2 (TCO2Eq)	Refrigerant charge circuit 2 (kg)	Refrigerant charge circuit 2 (TCO2Eq)
EWADH15T-SS/SL/SR B3	R134a	1430	3	50	71	50	71	50	71
EWADH16T-SS/SL/SR B3	R134a	1430	3	66	94	55	79	55	79
EWADC17T-SS/SL/SR B3	R134a	1430	3	66	94	66	94	55	79
EWADH18T-SS/SL/SR B3	R134a	1430	3	66	94	66	94	66	94
EWADC19T-SS/SL/SR B3	R134a	1430	3	81	116	72	103	72	103
EWADC20T-SS/SL/SR B3	R134a	1430	3	87	124	87	124	77	110
EWADC21T-SS/SL/SR B3	R134a	1430	3	93	133	93	133	93	133
EWADH15T-XS/XL/XR B3	R134a	1430	3	55	79	55	79	55	79
EWADH16T-XS/XL/XR B3	R134a	1430	3	72	103	60	86	60	86
EWADC17T-XS/XL/XR B3	R134a	1430	3	77	110	77	110	64	91
EWADH18T-XS/XL/XR B3	R134a	1430	3	83	119	83	119	83	119
EWADC19T-XS/XL/XR B3	R134a	1430	3	93	133	83	119	83	119
EWADC20T-XS/XL/XR B3	R134a	1430	3	93	133	93	133	83	119

Note: Equipment contains fluorinated greenhouse gases. Actual refrigerant charge depends on the final unit construction, details can be found on the unit labels.

Versions This range is available in two different versions:

STANDARD EFFICIENCY (Eurovent conditions according EN14511)

17 sizes to cover a range from 290 up to 2148 kW with an EER up to 3.04 and an ESEER up to 3.93 (data referred to Standard Noise).

HIGH EFFICIENCY (Eurovent conditions according EN14511)

17 sizes to cover a range from 351 up to 2087 kW with an EER up to 3.15 and an ESEER up to 4.05 (data referred to Standard Noise).

The EER (Energy Efficiency Ratio) is the ratio of the Cooling Capacity to the Power Input of the unit. The Power Input includes: the power input for operation of the compressors, the power input of all control and safety devices, the power input for fans.

The ESEER (European Seasonal Energy Efficiency Ratio) is a weighed formula enabling to take into account the variation of EER with the load rate and the variation of air inlet condenser temperature.
 $ESEER = A \times EER_{100\%} + B \times EER_{75\%} + C \times EER_{50\%} + D \times EER_{25\%}$
 K = Coefficient; T = Air inlet condenser temperature.

Sound configurations Standard, low and reduced sound configurations available as follows:

STANDARD SOUND

Condenser fan rotating at 900 rpm, rubber antivibration under compressor

LOW SOUND

Compressor fan rotating at 900 rpm, rubber antivibration under compressor and the sound attenuation is achieved thanks to special connections at the suction of each compressor that allows to reduce drastically the vibration transmission.

REDUCED SOUND

Compressor fan rotating at 700 rpm, rubber antivibration under compressor and the compressors are closed into a soundproof cabinet especially designed to minimize the sound emissions. Also special connections at the suction of each compressor allow to reduce drastically the vibration transmission.

Cabinet and structure The cabinet is painted to provide a high resistance to corrosion. Color Ivory White (Munsell code 5Y7.5/1) (\pm RAL7044). The base frame has eye-hooks to lift the unit with ropes for an easy installation. The weight is uniformly distributed along the profiles of the baseframe and this facilitates the arrangement of the unit.

Compressor (Asymmetric Single Screw) The compressor is semi-hermetic, single-screw type with gate-rotor made with the latest high-strength fiber reinforced star material. The compressor has an asymmetric slide regulation managed by the unit controller for infinitely modulating capacity from 100% to 25%. An integrated high efficiency oil separator maximizes the oil separation and standard start is Wye-Delta (Y- Δ) type.

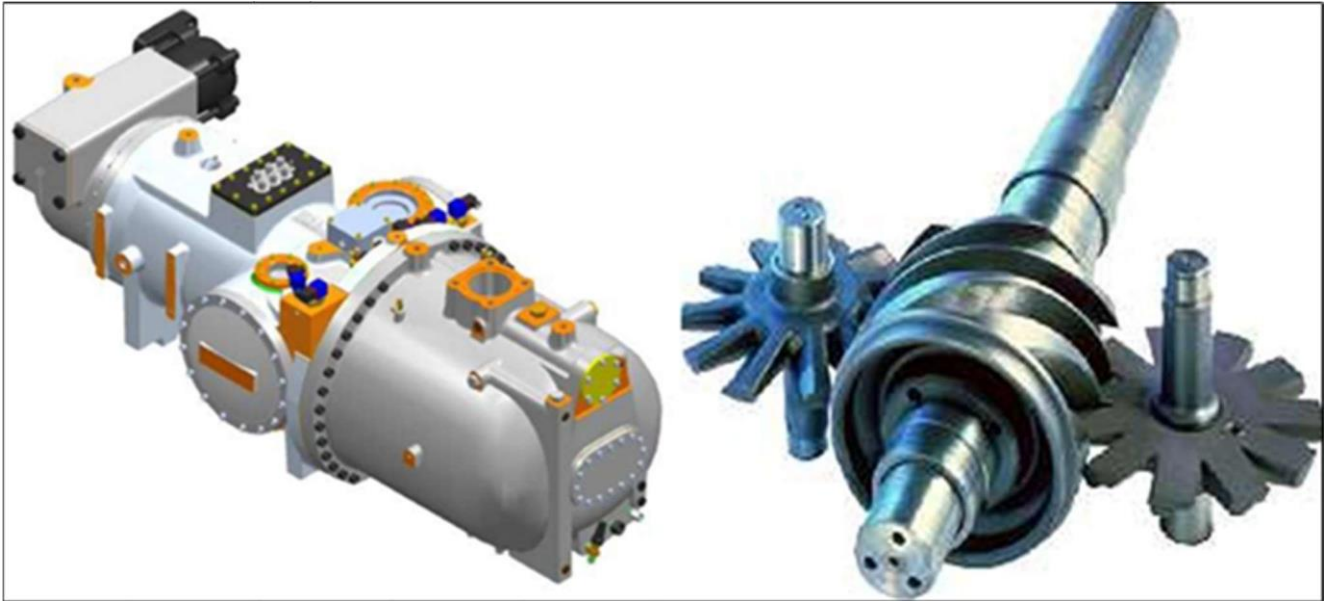

Condenser The condenser is made entirely of aluminum with flat tubes containing small channels. Full-depth louvered aluminum fins are inserted between the tubes maximizing the heat exchange. The Microchannel technology ensures the highest performance with the minimum surface for the exchanger. The quantity of refrigerant is also reduced compared to Cu/Al condenser. Special treatment ensure resistance to the corrosion by atmospheric agents extending the life time.

Note : for application in industrial, costal high polluted urban environment or combinations of the above a proper evaluation is needed to understand if, according to the specific environment, additional protections measures are needed.

Condenser fans (\varnothing 800) The condenser fans are propeller type with high efficiency design blades to maximize performances. The material of the blades is glass reinforced resin and each is protected by a guard. Fan motors are internally protected from overtemperature and are IP54.

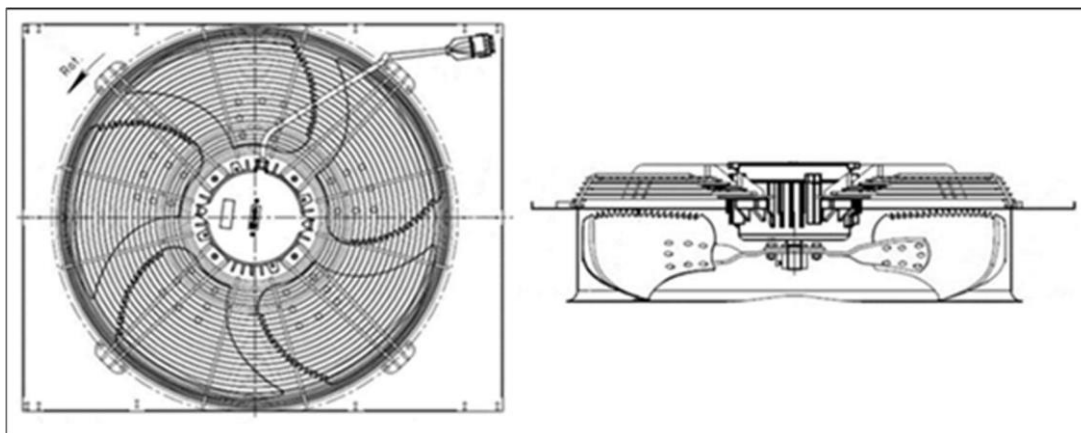

Electronic expansion valve The unit is equipped with the most advanced electronic expansion valve to achieve precise control of refrigerant mass flow. As today's system requires improved energy efficiency, tighter temperature control, wider range of operating conditions and incorporate features like remote monitoring and diagnostics, the application of electronic expansion valves becomes mandatory. Electronic expansion valves possesses unique features: short opening and closing time, high resolution, positive shut-off function to eliminate use of additional solenoid valve, continuous modulation of mass flow without stress in the refrigerant circuit and corrosion resistance stainless steel body. Electronic expansion valves are typically working with lower ΔP between high and low pressure side, than a thermostatic expansion valve. The electronic expansion valve allows the system to work with low condenser pressure (winter time) without any refrigerant flow problems and with a perfect chilled water leaving temperature control.

Refrigerant circuit Each unit has 2 independent refrigerant circuits and each one includes:

- Compressor with integrated oil separator
- Refrigerant
- Evaporator
- Air Cooled Condenser
- Electronic expansion valve
- Discharge line shut off valve
- Liquid line shut off valve
- Sight glass with moisture indicator
- Filter drier
- Charging valves
- High pressure switch
- High pressure transducers
- Low pressure transducers
- Oil pressure transducer
- Suction temperature sensor

Electrical control panel Power and control are located in the main panel that is manufactured to ensure protection against all weather conditions. The electrical panel is IP54 and (when opening the doors) internally protected against possible accidental contact with live parts. The main panel is fitted with a main switch interlocked door that shuts off power supply when opening.

Power Section The power section includes compressors and fans protection devices, fans starters and control circuit power supply.

MicroTech III controller MicroTech III controller is installed as standard; it can be used to modify unit set-points and check control parameters. A built-in display shows chiller operating status plus temperatures and pressures of water, refrigerant and air, programmable values, set-points. A sophisticated software with predictive logic, selects the most energy efficient combination of compressors, EEXV and condenser fans to keep stable operating conditions to maximize chiller energy efficiency and reliability. MicroTech III is able to protect critical components based on external signals from its system (such as motor temperatures, refrigerant gas and oil pressures, correct phase sequence, pressure switches and evaporator). The input coming from the high pressure switch cuts all digital output from the controller in less than 50ms, this is an additional security for the equipment. Fast program cycle (200ms) for a precise monitoring of the system.

Floating point calculations supported for increased accuracy in Pressure / Temperature conversions.

Control section - main features

Main control features are (for more information refer to Unit Control Manual):

- Optimized management of compressors stepless capacity control through inverter drive.
- Display of evaporator entering/leaving water temperatures.

- Display of Ambient Temperature
- Display of refrigerant condensing/evaporating temperatures and pressures.
- Regulation of leaving evaporator water (cooling mode) or condenser water (heating mode).
- Display of compressor working hours and number of compressor starts.
- Re-start in case of power failure (automatic or manual depending on failure type).
- Soft load (optimized management of the compressor load during the start-up).
- Set point reset.
- Master/Slave operation (up to 4 chillers connected).
- Variable Primary Flow Management (available as option)

Alarms signaling (for more information refer to Unit Control Manual):

- Phase loss.
- Evaporator water flow loss.
- Evaporator water freezing protection.
- External alarm.
- Low evaporator refrigerant pressure.
- High refrigerant pressure (transducer).
- High refrigerant pressure (switch).
- Low pressure ratio.
- High refrigerant discharge temperature.
- High oil pressure differential.
- High motor temperature.

System security The following securities are available.

- Phase monitor.
- Low Ambient temperature lock-out.
- Freeze protection.

Regulation type Proportional integral derivative regulation on the evaporator leaving water output probe.

MicroTech III MicroTech III built-in terminal has the following features.

- 164x44 dots liquid crystal display with white back lighting. Supports Unicode fonts for multi-lingual.
- Key-pad consisting of 3 keys.
- Push'n'Roll control for an increased usability.
- Memory to protect the data.
- General faults alarm relays.
- Password access to modify the setting.
- Application security to prevent application tampering or hardware usability with third party applications.
- Service report displaying all running hours and general conditions.
- Alarm history memory to allow an easy fault analysis.

Supervising systems (on request) MicroTech III remote communication MicroTech III is able to communicate to BMS (Building Management System) based on the most common protocols as:

- ModbusRTU (Native)
- LonWorks, now also based on the international 8040 Standard Chiller Profile and LonMark Technology.
- BacNet BTP certified over IP and MS/TP (class 4) (Native).
- Ethernet TCP/IP (Native).

Nomenclature

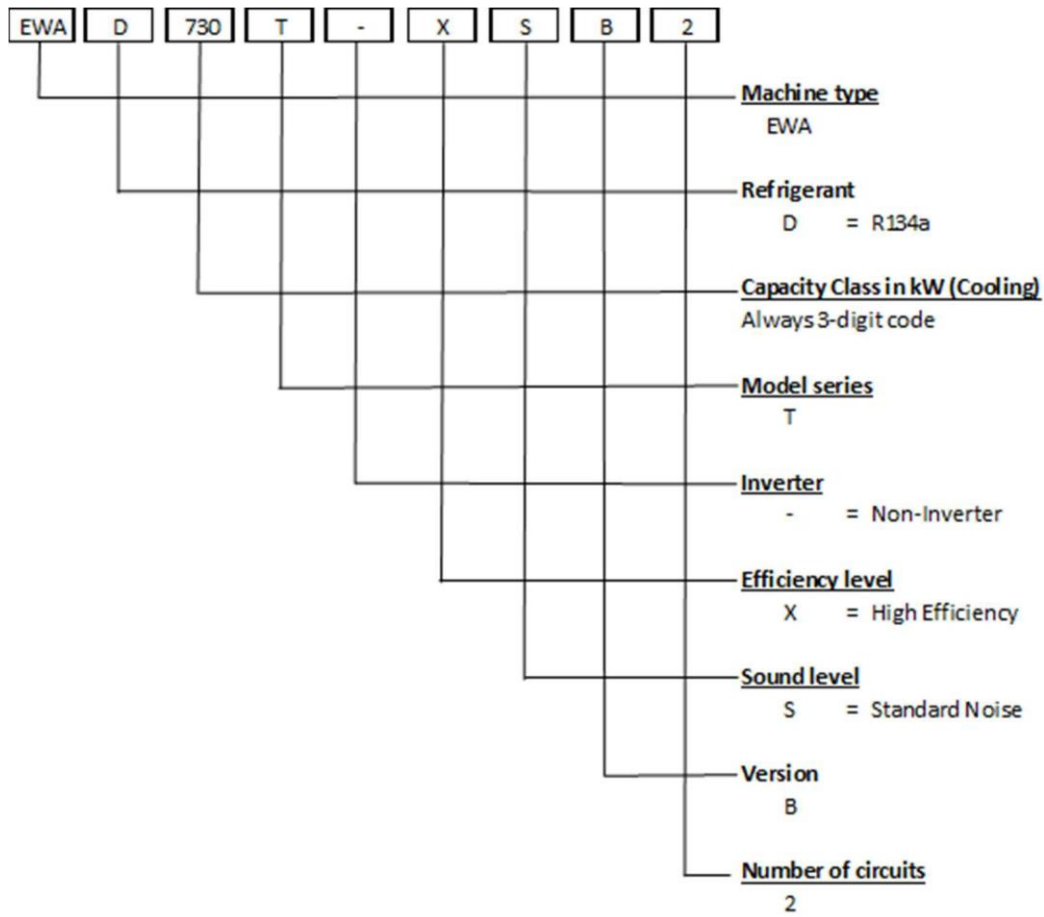

Standard Options (supplied on basic unit)

Wye -Delta compressor starter [Y-D] (opt. code 05 – provided as standard) For low inrush current and reduced starting torque – *Opt. incompatibility: 06*

Double set point (opt. code 10 – provided as standard) Dual leaving water temperature set points

Phase monitor (opt. code 13 – provided as standard) Device that monitors input voltage and stops the chiller in case of phase loss or wrong phase sequence.

Evaporator Victaulic KIT (opt. code 20 – provided as standard) Victaulic kit includes the victaulic joint and the counter pipe fitted with victaulic groove to be welded with the plant pipes. *Opt. incompatibility: 21*

20mm evaporator insulation (opt. code 29 – provided as standard) The external shell is covered with a 20mm closed cell insulation material. *Opt. incompatibility: 08*

Electronic expansion valve (opt. code 60 – provided as standard)

Discharge line shut-off valve (opt. code 61 – provided as standard) Installed on the discharge port of the compressor to facilitate maintenance operation.

Set point reset, demand limit and alarm from external device (opt. code 67/90 – provided as standard) Setpoint Reset: The leaving water temperature set-point can be overwritten with an external 4-20mA, through the ambient temperature, or through the evaporator water temperature ΔT . Demand Limit: Chiller capacity can be limited through an external 4-20mA signal or via network. Alarm from external device: The unit controller is able to receive an external alarm signal. The user can decide whether this alarm signal will stop the unit or not.

Hour run meter (opt. code 68 – provided as standard)

General fault contactor (opt. code 69 – provided as standard)

Fans circuit breakers (opt. code 96 – provided as standard) Safety devices that, added to the standard protection devices, protect fan motors against overload and overcurrent.

Main switch interlock door (opt. code 97 – provided as standard)

Unit right water connection (opt. code 101) - Available on request.

Master / Slave (opt. code 128 – provided as standard) The EWAD~T -B features the new DAIKIN Master/ Slave (M/S) control. Once set which unit has the role of master, the other(s) will operate as slave(s) based on the inputs provided by the master.

The chillers must be installed in parallel in the hydronic plant.

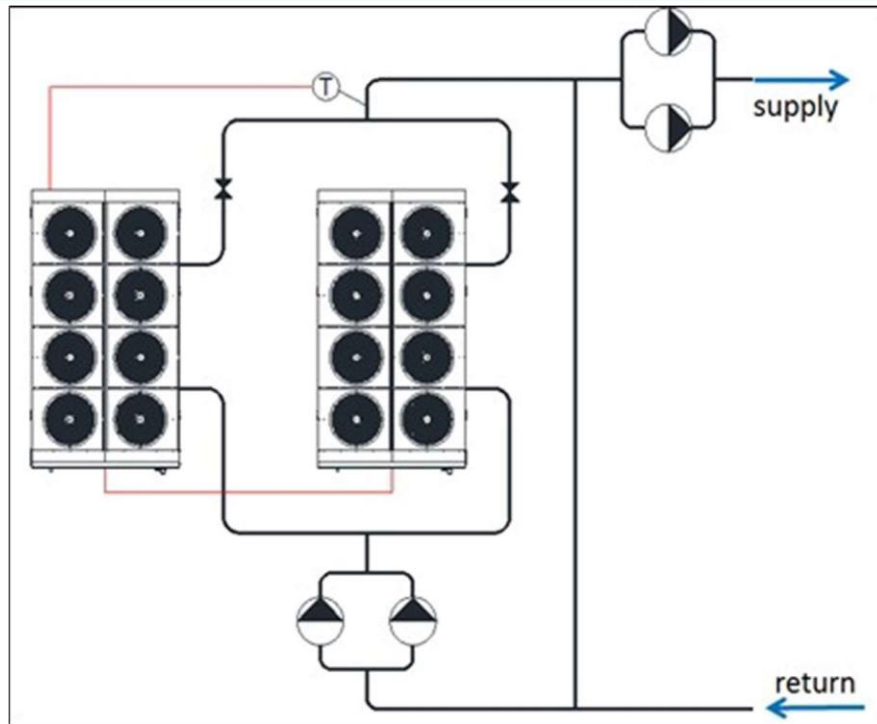

with Master / Slave control is possible to:

- balance the working hours of the compressors enhancing reliability and extending the life of the system;
- balancing the load between the units to maximize the efficiency of the system;

In order to operate in Master / Slave mode an additional probe (PT1000 or NTC10K) must be installed on the common line of the plant and connected to the master unit. The additional probe is not provided by the factory. Master / Slave can manage units selected with pump on board (fix speed and inverter driven pumps).

Note: check valves must be installed at the outlet of each chiller. Master / Slave can also manage the start and stop of external pumps (not provided by factory). The power supply of external pumps is not provided by the unit.

Mechanical options (on request)

Total Heat Recovery (opt. code 01) A plate to plate heat exchanger for each refrigerant circuit is installed in series to the air condenser coil. There is no switch nor solenoid valve in the circuit, thus compressor discharged refrigerant is always flowing through the heat recovery exchanger and warm water production is always available while the chiller is providing cooling. The amount of heat recovered is about the 80/85% (according to the operating conditions) of the total heat rejection of the chiller. The chiller perform the control on the recovery circuit, based on the return water temperature to the unit. Heat recovery capability is subject to cooling load demand (if no cooling demand is present then no heat recovery is available) - *Opt. incompatibility: 03*

Partial Heat Recovery (opt. code 03) A plate to plate heat exchanger for each refrigerant circuit is installed in series to the air condenser coil. There is no switch nor solenoid valve in the circuit, thus compressor discharged refrigerant is always flowing through the heat recovery exchanger and warm water production is always available while the chiller is providing cooling. The unit controller does not manage the partial heat recover operation. The recover must be managed from the plant manager that controls the operation of the pump on the recovery circuit. The amount of heat recovered is about the 15/20% (according to the operating conditions) of the total heat rejection of the chiller. Heat recovery capability is subject to cooling load demand (if no cooling demand is present then no heat recovery is available) - *Opt. incompatibility: 01*

Brine Version (opt. code 08) For operation with temperature at the outlet of the evaporator below 4°C, the unit must operate with glycol mixture (with ethylene or propylene glycol) and the Brine Version option must be selected. The Brine version provides dedicated control function and enhanced insulation - *Opt. incompatibility: 29*

Evaporator flange KIT (opt. code 21) The flange kit includes flange, counter-flange and gaskets, bolted together with fasteners and nuts - *Opt. incompatibility: 20*

Suction line shut-off valve (opt. code 62) Installed on the suction port of the compressor to facilitate maintenance operation.

High pressure side manometers (opt. code 63)

Low pressure side manometers (opt. code 64)

Hydronic kits:

- **One centrifugal pump (Low lift) (opt. code 78)** - *Opt. incompatibility: all the other centrifugal pumps*

- **One centrifugal pump (high lift) (opt. code 79)** - *Opt. incompatibility: all the other centrifugal pumps*

- **Two centrifugal pumps (Low lift) (opt. code 80)** - *Opt. incompatibility: all the other centrifugal pumps*

- **Two centrifugal pumps (high lift) (opt. code 81)** - *Opt. incompatibility: all the other centrifugal pumps*

Unit mounted hydronic kits are available with single and dual pumps. The Low lift kits provides an average available head of 100 kPa at chiller standard conditions. The High lift kits provides an average available head of 200 kPa at chiller standard conditions. The kit is completed with pressure gauge, safety valve, drain valve. The motor pump is protected by a circuit breaker installed in control panel. The kit is assembled and wired to the control panel. The pipe and pump are protected from freezing with an additional electrical heater. In case of unit equipped with hydronic kit on board selected to operate with glycol mixture, contact factory.

Double pressure relief valve with diverter (opt. code 91)

E-coating microchannel coils (opt. code 139) As protection, a layer of an epoxy polymer is added on the surface of the exchanger. The process consists in the complete immersion of the exchanger in the epoxy polymer solution. An electric voltage applied to the exchanger causes a difference with the electrical charge of the polymer molecules that, as result, are drawn to the metal. The thickness controlled by the applied voltage. The result is a uniform layer of epoxy polymers applied all over the exchanger surface. A final UV top-coat treatment is applied on the coil surface. The treatment is recommended in all application where high risk of corrosion exist (eg: high polluted urban, costal, industrial environments and their combinations). *Opt. incompatibility: 153.*

Unit guards (to cover unit access) (opt. code 140) Wire mesh that cover the access around the unit.

Side panels on coil ends (opt. code 141) Protection carter on both side of each condensing module.

Blue coat (opt. code 153) An epoxy powder is sprayed and electrostatically fixed to the coil. Once the surface is completely covered by the epoxy material, the coil is sent in to a furnace for the drying and curing phase. The result is a uniform and durable coating that enhances the resistance to corrosion. The treatment is recommended in all applications where a moderate risk of corrosion exists (e.g.: urban, coastal, industrial environments) - Opt. incompatibility: 139

Electrical options (on request)

Soft Starter (opt. code 06) Electronic starting device, alternative to WYE – DELTA compressor starter, adopted to reduce the mechanical stress during compressor start-up - *Opt. incompatibility: 05-11-110*

Compressor thermal overloads relays (opt. code 11) Safety electronic devices that, added to the standard protection devices, protect compressor motors against overload and current unbalance - *Opt. incompatibility: 95*

Under over voltage control (opt. code 15) Electronic device that monitors and displays input voltage, and stops the chiller in case of phase loss, wrong phase sequence, or voltage exceeding minimum and maximum allowed values.

Energy meter (including current limit) (opt. code 16a) Device installed inside the control box that displays all chiller electrical power parameters at line input such as line voltage and phase current, input active and reactive power, active and reactive energy, including current limit option. An integrated RS485 module allows a Modbus communication to an external BMS.

Current limit (opt. code 19) The option, enabled from the unit controller, limits the maximum absorbed current of the chiller and so indirectly the cooling capacity of the unit.

Speedtrol (opt. code 42) Continuous fan speed regulation on the first fan (VFD driven) of each circuit. It allows unit operation down to -18°C - *Opt. incompatibility: 99a-142*

Evaporator electric heater (opt. code 57) 125W electric heater, controlled by a thermostat (heater is activated if water temperature is <5°C) and installed in the evaporator.

Evaporator flow switch (opt. code 58) Supplied separately to be wired and installed on the evaporator water piping (by the customer). The installation of the flow switch is mandatory.

Compressors circuit breakers (opt. code 95) Safety devices that include in a single device all safety functions otherwise provided by standard fuses and optional thermal relays, such as protection against overcurrent, overload, current unbalance - *Opt. incompatibility: 11.*

Fans speed regulation opt. code 99a) - Continuous fan speed regulation of all fans (VFD driven) for improved sound level of the unit during low ambient temperature operation. At very low temperatures, all fans except the first are switched off thus allowing unit operation down to -18°C - *Opt. incompatibility: 142-42-96.*

Ground fault relay (opt. code 102) To shut down the entire unit if a ground fault condition is detected.

Rapid restart (opt. code 110) Rapid Restart is the ideal solution for those application where we cannot afford the loose of cooling such as data centers, health care facilities, process cooling ...etc. For this kind of applications, in case of a power failure, chiller equipment are required to restore the cooling supply to the system as fast as possible. Standard unit (without the Rapid Restart option) will be starting within 310 seconds after the power is restored and it will be reaching full load cooling capacity within 20 ÷ 25 minutes (obviously depending on the load demand). Rapid Restart is allowing the chiller to start as fast as 30 seconds after power is restored and to reach full load cooling capacity in less than 6 minutes from the unit restart.

For more details about this option please refer to the Control Manual.

Inverter kit for pumps:

- **INVERTER KIT FOR 1 CENTR PUMP LOW LIFT (opt. code 120e)** *Opt. incompatibility: 79-80- 81-120f-120g-120h*

- **INVERTER KIT FOR 1 CENTR PUMP HIGH LIFT (opt. code 120f)** *Opt. incompatibility: 78- 80-81-120e -120g-120h*

- **INVERTER KIT FOR 2 CENTR PUMPS LOW LIFT (opt. code 120g)** *Opt. incompatibility: 78-79-81-120e-120f-120h*

- **INVERTER KIT FOR 2 CENTR PUMPS HIGH LIFT (opt. code 120h)** *Opt. incompatibility: 78-79-80-120e-120f-120g*

note: the Inverter kit must be associated with the corresponding hydronic kit (opt. code 78/79/80/81). Piping between the inertial tank and the unit is not included. Electric heater power supply has to be provided from external source.

The inverter kit can be used for the following purposes:

- **Tuning the water flow during unit commissioning.**
- **Control the pump speed via external input from Building Management System (BMS).** For this application a 0-10V signal for the pump speed must be provided from the plant manager according to the specific control strategy of the plant. The water must be within the minimum and maximum value allowed for the unit (refer to the "Operating limit" chapter). The change in water flow rate must not be exceed more than 10% of the design water flow rate per minute.
- **Set a "thermostat off" pump speed .** Providing the unit with the inverter kit for the on-board pump is possible to manage two different water flow settings. A setting for water flow during the "Thermostat ON" mode (when the chiller is actually providing cooling to the plant), and a set for the "thermostat off" mode (when the plant load is satisfied and the compressors are waiting to start). This feature allows to achieve energy saving on plant operating cost by reducing the speed of the pumps when the chiller has reached the set point.

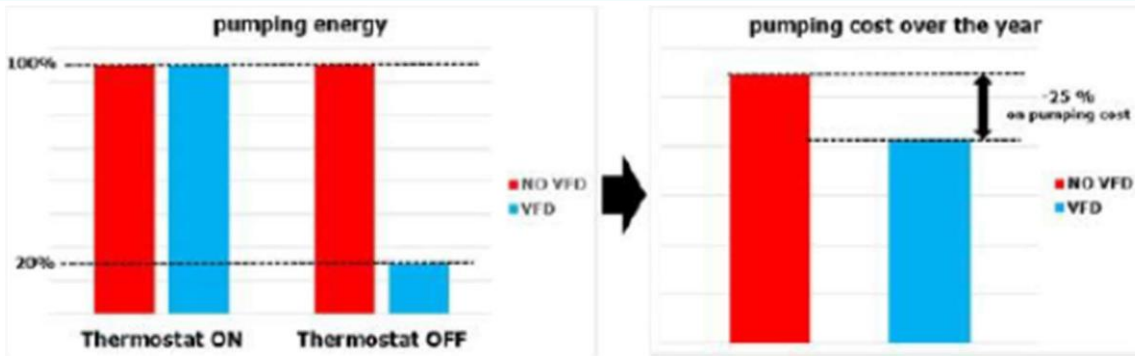

Thanks to the saving on pumping cost, the payback time for the Inverter Kit is approximately one year.

High ambient kit (opt. code 142) - The high ambient kit must be selected in case of design condition from 46°C ambient and above. It consists of oversized electrical equipment, enhanced ventilation for the electrical box (according to the selected size), sunshield.

Daikin on site modem with antenna (opt. code 155) - Whenever LAN connection to the unit will not be available, connecting the unit to Daikin on Site will be possible through a dedicated 3G M2M modem that can be ordered from Factory. When ordered, the modem will be installed on the unit before leaving the Factory.

Installation options (on request)

Rubber anti vibration mounts (opt. code 75) Supplied separately, these are positioned under the base of the unit during installation. Ideal to reduce the vibrations when the unit is floor mounted - *Opt. incompatibility: 77*

Spring anti vibration mounts (opt. code 77) Supplied separately, these are positioned under the base of the unit during installation. Ideal for dampening vibrations for installation on roofs and metallic structures - *Opt. incompatibility: 75*

Other options (on request)

Container kit (opt. 71) - *Opt. incompatibility: 112*

Transport kit (opt. code 112) - *Opt. incompatibility: 71*

External tank (opt. code 83, 84, 87, 88) Tank shipped loose with the unit. This can be ordered with or without cabinet and 500l or 100l) - *Opt. incompatibility: only one external tank has to be selected.*

Witness test & acoustic test

EWAD~T-SSB

MODEL		EWAD290T-SS B2	EWAD330T-SS B2	EWAD370T-SS B2	EWAD400T-SS B2	EWAD430T-SS B2	EWAD510T-SS B2
COOLING PERFORMANCE							
Capacity - Cooling	kW	291	335	373	401	430	506
Capacity control - Type		Stepless	Stepless	Stepless	Stepless	Stepless	Stepless
Capacity control - Minimum capacity	%	12.5	12.5	12.5	12.5	12.5	12.5
Unit power input - Cooling	kW	92.7	111	120	131	141	166
EER		3.14	3.00	3.09	3.06	3.04	3.04
ESEER		3.86	3.73	3.74	3.66	3.65	3.87
IPLV		4.48	4.38	4.37	4.37	4.28	4.83
CASING							
Colour *		IW	IW	IW	IW	IW	IW
Material *		GPSS	GPSS	GPSS	GPSS	GPSS	GPSS
DIMENSIONS							
Height	mm	2540	2540	2540	2540	2540	2540
Width	mm	2258	2258	2258	2258	2258	2258
Length	mm	3230	3230	4130	4130	4130	4130
WEIGHT							
Unit Weight	kg	3061	3061	4104	4114	4124	4724
Operating Weight	kg	3161	3161	4274	4284	4294	4894
WATER HEAT EXCHANGER							
Type *		S&T	S&T	S&T	S&T	S&T	S&T
Water Volume	l	89	89	181	175	164	164
Water flow rate	l/s	13.9	16.0	17.9	19.2	20.6	24.2
Water pressure drop	kPa	28.5	31.1	42.0	47.3	39.5	30.5
Insulation material *		CC	CC	CC	CC	CC	CC
AIR HEAT EXCHANGER							
Type *		MCH	MCH	MCH	MCH	MCH	MCH
FAN							
Type *		ON-OFF (DPT)	ON-OFF (DPT)	ON-OFF (DPT)	ON-OFF (DPT)	ON-OFF (DPT)	ON-OFF (DPT)
Drive *		On/Off	On/Off	On/Off	On/Off	On/Off	On/Off
Diameter	mm	800	800	800	800	800	800
Nominal air flow	l/s	33129	33129	44172	44172	44172	44172
Quantity	No.	6	6	8	8	8	8
Speed	rpm	900	900	900	900	900	900
Motor input	kW	10.0	10.0	13.4	13.4	13.4	13.4
COMPRESSOR							
Type		Asymm Single Screw	Asymm Single Screw	Asymm Single Screw	Asymm Single Screw	Asymm Single Screw	Asymm Single Screw
Oil charge	l	26.0	26.0	26.0	26.0	26.0	32.0
Quantity	No.	2	2	2	2	2	2
SOUND LEVEL**							
Sound Power - Cooling	dB(A)	98	98	98	98	98	101
Sound Pressure level@1m distance - Cooling	dB(A)	78	78	78	78	78	81
REFRIGERANT CIRCUIT							
Refrigerant type		R134a	R134a	R134a	R134a	R134a	R134a
Refrigerant charge	kg	50	50	55	56	58	58
N. of circuits	No.	2	2	2	2	2	2
PIPING CONNECTIONS							
Evaporator water inlet/outlet	mm	114.3	114.3	139.7	139.7	139.7	139.7

All the performances (Cooling capacity, unit power input in cooling and EER) are based on the following conditions: evaporator 12.0/7.0°C; ambient 35.0°C, unit at full load operation; operating fluid: Water ; fouling factor = 0.

(* IW: Ivory White; GPSS: Galvanized and Painted Steel Sheet; PHE: Plate Heat Exchanger; S&T: Single Pass Shell & Tube; MCH: Microchannel; CC: Closed Cell; DPT: Direct Propeller Type; DOL: Direct On Line - VFD: Inverter - BRS: Brushless

(**) Sound power level (referred to evaporator 12/7°C, ambient 35°C full load operation) are measured in accordance with ISO 9614 and Eurovent 8/1 for Eurovent certified units. The certification refers only to the overall sound power level, the sound pressure is calculated from the sound power level and are for information only and not considered binding.

The minimum capacity indicated is referred to unit operating at standard Eurovent conditions. Dimensions and weights are for indication only and not considered binding. Before designing the installation, consult the official drawings available from the factory at request. All the data are referred to standard unit without options. Data are subject to change without notice.

EWAD~T-SSB

MODEL		EWAD520T-SS B2	EWAD580T-SS B2	EWAD700T-SS B2	EWAD800T-SS B2	EWAD940T-SS B2	EWADC10T-SS B2
COOLING PERFORMANCE							
Capacity - Cooling	kW	523	576	701	810	936	1.000
Capacity control - Type		Stepless	Stepless	Stepless	Stepless	Stepless	Stepless
Capacity control - Minimum capacity	%	12.5	12.5	12.5	12.5	12.5	12.5
Unit power input - Cooling	kW	171	189	234	266	308	340
EER		3.06	3.04	3.00	3.04	3.04	2.93
ESEER		3.95	4.05	3.87	3.89	3.82	3.89
IPLV		5.38	5.49	4.93	4.55	4.69	4.61
CASING							
Colour *		IW	IW	IW	IW	IW	IW
Material *		GPSS	GPSS	GPSS	GPSS	GPSS	GPSS
DIMENSIONS							
Height	mm	2540	2540	2537	2537	2537	2537
Width	mm	2258	2258	2282	2282	2282	2282
Length	mm	5030	5030	5976	5976	6876	6876
WEIGHT							
Unit Weight	kg	4860	4860	5527	5525	5858	5858
Operating Weight	kg	5030	5030	5825	5825	6188	6188
WATER HEAT EXCHANGER							
Type *		S&T	S&T	S&T	S&T	S&T	S&T
Water Volume	l	170	164	315	240	289	289
Water flow rate	l/s	25.0	27.6	33.6	38.7	44.8	47.8
Water pressure drop	kPa	43.6	60.4	51.4	32.4	39.5	44.7
Insulation material *		CC	CC	CC	CC	CC	CC
AIR HEAT EXCHANGER							
Type *		MCH	MCH	MCH	MCH	MCH	MCH
FAN							
Type *		ON-OFF (DPT)	ON-OFF (DPT)	ON-OFF (DPT)	ON-OFF (DPT)	ON-OFF (DPT)	ON-OFF (DPT)
Drive *		On/Off	On/Off	On/Off	On/Off	On/Off	On/Off
Diameter	mm	800	800	800	800	800	800
Nominal air flow	l/s	55214	55214	66257	66257	77300	77300
Quantity	No.	10	10	12	12	14	14
Speed	rpm	900	900	900	900	900	900
Motor input	kW	16.7	16.7	20.0	20.0	23.4	23.4
COMPRESSOR							
Type		Asymm Single Screw	Asymm Single Screw	Asymm Single Screw	Asymm Single Screw	Asymm Single Screw	Asymm Single Screw
Oil charge	l	32.0	32.0	34.0	34.0	42.0	42.0
Quantity	No.	2	2	2	2	2	2
SOUND LEVEL**							
Sound Power - Cooling	dB(A)	101	101	99	99	99	100
Sound Pressure level@1m distance - Cooling	dB(A)	81	81	78	78	78	79
REFRIGERANT CIRCUIT							
Refrigerant type		R134a	R134a	R134a	R134a	R134a	R134a
Refrigerant charge	kg	66	67	93.6	93.6	109.2	109.2
N. of circuits	No.	2	2	2	2	2	2
PIPING CONNECTIONS							
Evaporator water inlet/outlet	mm	139.7	139.7	168.3	168.3	168.3	168.3

All the performances (Cooling capacity, unit power input in cooling and EER) are based on the following conditions: evaporator 12.0/7.0°C; ambient 35.0°C, unit at full load operation; operating fluid: Water ; fouling factor = 0.

(*) IW: Ivory White; GPSS: Galvanized and Painted Steel Sheet; PHE: Plate Heat Exchanger; S&T: Single Pass Shell & Tube; MCH: Microchannel; CC: Closed Cell; DPT: Direct Propeller Type; DOL: Direct On Line - VFD: Inverter - BRS: Brushless

(**) Sound power level (referred to evaporator 12/7°C, ambient 35°C full load operation) are measured in accordance with ISO 9614 and Eurovent 8/1 for Eurovent certified units. The certification refers only to the overall sound power level, the sound pressure is calculated from the sound power level and are for information only and not considered binding.

The minimum capacity indicated is referred to unit operating at standard Eurovent conditions. Dimensions and weights are for indication only and not considered binding. Before designing the installation, consult the official drawings available from the factory at request. All the data are referred to standard unit without options. Data are subject to change without notice.

EWAD~T-SSB

MODEL		EWADH10T-SS B2	EWADC11T-SS B2	EWADH12T-SS B2	EWADH13T-SS B2	EWADH14T-SS B2	EWADH15T-SS B3
COOLING PERFORMANCE							
Capacity - Cooling	kW	1.052	1.136	1.268	1.353	1.457	1.457
Capacity control - Type		Stepless	Stepless	Stepless	Stepless	Stepless	Stepless
Capacity control - Minimum capacity	%	12.5	12.5	12.5	12.5	12.5	12.5
Unit power input - Cooling	kW	362	387	438	464	490	534
EER		2.90	2.93	2.89	2.91	2.97	2.96
ESEER		3.74	3.77	3.77	3.79	3.80	3.89
IPLV		4.41	4.46	4.46	4.50	4.53	4.58
CASING							
Colour *		IW	IW	IW	IW	IW	IW
Material *		GPSS	GPSS	GPSS	GPSS	GPSS	GPSS
DIMENSIONS							
Height	mm	2537	2537	2537	2537	2537	2537
Width	mm	2282	2282	2282	2282	2282	2282
Length	mm	6876	7776	7776	8676	9576	10509
WEIGHT							
Unit Weight	kg	6229	6520	6780	8084	8426	9938
Operating Weight	kg	6710	6981	7272	8554	8887	10460
WATER HEAT EXCHANGER							
Type *		S&T	S&T	S&T	S&T	S&T	S&T
Water Volume	l	518	502	492	470	461	522
Water flow rate	l/s	50.3	54.3	60.7	64.7	69.8	75.5
Water pressure drop	kPa	41.6	32.7	34.2	44.5	61.3	43.8
Insulation material *		CC	CC	CC	CC	CC	CC
AIR HEAT EXCHANGER							
Type *		MCH	MCH	MCH	MCH	MCH	MCH
FAN							
Type *		ON-OFF (DPT)	ON-OFF (DPT)	ON-OFF (DPT)	ON-OFF (DPT)	ON-OFF (DPT)	ON-OFF (DPT)
Drive *		On/Off	On/Off	On/Off	On/Off	On/Off	On/Off
Diameter	mm	800	800	800	800	800	800
Nominal air flow	l/s	77300	88343	88343	99386	110429	12472
Quantity	No.	14	16	16	18	20	22
Speed	rpm	900	900	900	900	900	900
Motor input	kW	23.4	26.7	26.7	30.1	33.4	36.7
COMPRESSOR							
Type		Asymm Single Screw	Asymm Single Screw	Asymm Single Screw	Asymm Single Screw	Asymm Single Screw	Asymm Single Screw
Oil charge	l	42.0	42.0	50.0	50.0	50.0	75.0
Quantity	No.	2	2	2	2	2	3
SOUND LEVEL**							
Sound Power - Cooling	dB(A)	100	100	100	101	101	103
Sound Pressure level@ 1m distance - Cooling	dB(A)	79	78	78	79	79	80
REFRIGERANT CIRCUIT							
Refrigerant type		R134a	R134a	R134a	R134a	R134a	R134a
Refrigerant charge	kg	109.2	124.8	124.8	140.4	156	172
N. of circuits	No.	2	2	2	2	2	3
PIPING CONNECTIONS							
Evaporator water inlet/outlet	mm	219.1	219.1	219.1	219.1	219.1	219.1

All the performances (Cooling capacity, unit power input in cooling and EER) are based on the following conditions: evaporator 12.0/7.0°C; ambient 35.0°C, unit at full load operation; operating fluid: Water ; fouling factor = 0.

(*) IW: Ivory White; GPSS: Galvanized and Painted Steel Sheet; PHE: Plate Heat Exchanger; S&T: Single Pass Shell & Tube; MCH: Microchannel; CC: Closed Cell; DPT: Direct Propeller Type; DOL: Direct On Line - VFD: Inverter - BRS: Brushless

(**) Sound power level (referred to evaporator 12/7°C, ambient 35°C full load operation) are measured in accordance with ISO 9614 and Eurovent 8/1 for Eurovent certified units. The certification refers only to the overall sound power level, the sound pressure is calculated from the sound power level and are for information only and not considered binding.

The minimum capacity indicated is referred to unit operating at standard Eurovent conditions. Dimensions and weights are for indication only and not considered binding. Before designing the installation, consult the official drawings available from the factory at request. All the data are referred to standard unit without options. Data are subject to change without notice.

EWAD~T-SSB

MODEL		EWADH16T-SS B3	EWADC17T-SS B3	EWADH18T-SS B3	EWADC19T-SS B3	EWADC20T-SS B3	EWADC21T-SS B3
COOLING PERFORMANCE							
Capacity - Cooling	kW	1.684	1.762	1.871	1.967	2.065	2.148
Capacity control - Type		Stepless	Stepless	Stepless	Stepless	Stepless	Stepless
Capacity control - Minimum capacity	%	12.5	12.5	12.5	12.5	12.5	12.5
Unit power input - Cooling	kW	563	605	654	682	710	735
EER		2.99	2.91	2.86	2.88	2.91	2.92
ESEER		3.93	3.88	3.73	3.71	3.66	3.71
IPLV		4.61	4.54	4.45	4.46	4.40	4.53
CASING							
Colour *		IW	IW	IW	IW	IW	IW
Material *		GPSS	GPSS	GPSS	GPSS	GPSS	GPSS
DIMENSIONS							
Height	mm	2537	2537	2537	2537	2537	2537
Width	mm	2282	2282	2282	2282	2282	2282
Length	mm	11409	11409	11409	12309	13209	14109
WEIGHT							
Unit Weight	kg	10575	10575	10636	10902	11202	11422
Operating Weight	kg	11446	11446	11589	11855	12237	12457
WATER HEAT EXCHANGER							
Type *		S&T	S&T	S&T	S&T	S&T	S&T
Water Volume	l	871	871	953	953	1035	1035
Water flow rate	l/s	80.6	84.4	89.6	94.2	98.9	102
Water pressure drop	kPa	49.3	53.5	56.4	64.5	64.8	69.6
Insulation material *		CC	CC	CC	CC	CC	CC
AIR HEAT EXCHANGER							
Type *		MCH	MCH	MCH	MCH	MCH	MCH
FAN							
Type *		ON-OFF (DPT)	ON-OFF (DPT)	ON-OFF (DPT)	ON-OFF (DPT)	ON-OFF (DPT)	ON-OFF (DPT)
Drive *		On/Off	On/Off	On/Off	On/Off	On/Off	On/Off
Diameter	mm	800	800	800	800	800	800
Nominal air flow	l/s	132515	132515	132515	143557	154600	165643
Quantity	No.	24	24	24	26	28	30
Speed	rpm	900	900	900	900	900	900
Motor input	kW	40.1	40.1	40.1	43.4	46.8	50.1
COMPRESSOR							
Type		Asymm Single Screw	Asymm Single Screw	Asymm Single Screw	Asymm Single Screw	Asymm Single Screw	Asymm Single Screw
Oil charge	l	75.0	75.0	75.0	75.0	75.0	75.0
Quantity	No.	3	3	3	3	3	3
SOUND LEVEL**							
Sound Power - Cooling	dB(A)	103	103	103	103	103	103
Sound Pressure level@1m distance - Cooling	dB(A)	80	80	80	80	80	80
REFRIGERANT CIRCUIT							
Refrigerant type		R134a	R134a	R134a	R134a	R134a	R134a
Refrigerant charge	kg	187	187	187	203	218	234
N. of circuits	No.	3	3	3	3	3	3
PIPING CONNECTIONS							
Evaporator water inlet/outlet	mm	273	273	273	273	273	273

All the performances (Cooling capacity, unit power input in cooling and EER) are based on the following conditions: evaporator 12.0/7.0°C; ambient 35.0°C, unit at full load operation; operating fluid: Water ; fouling factor = 0.

(*) IW: Ivory White; GPSS: Galvanized and Painted Steel Sheet; PHE: Plate Heat Exchanger; S&T: Single Pass Shell & Tube; MCH: Microchannel; CC: Closed Cell; DPT: Direct Propeller Type; DOL: Direct On Line - VFD: Inverter - BRS: Brushless

(**) Sound power level (referred to evaporator 12/7°C, ambient 35°C full load operation) are measured in accordance with ISO 9614 and Eurovent 8/1 for Eurovent certified units. The certification refers only to the overall sound power level, the sound pressure is calculated from the sound power level and are for information only and not considered binding.

The minimum capacity indicated is referred to unit operating at standard Eurovent conditions. Dimensions and weights are for indication only and not considered binding. Before designing the installation, consult the official drawings available from the factory at request. All the data are referred to standard unit without options. Data are subject to change without notice.

EWAD~T-SLB

MODEL		EWAD290T-SL B2	EWAD330T-SL B2	EWAD370T-SL B2	EWAD400T-SL B2	EWAD430T-SL B2	EWAD510T-SL B2
COOLING PERFORMANCE							
Capacity - Cooling	kW	291	335	373	401	430	506
Capacity control - Type		Stepless	Stepless	Stepless	Stepless	Stepless	Stepless
Capacity control - Minimum capacity	%	12.5	12.5	12.5	12.5	12.5	12.5
Unit power input - Cooling	kW	92.7	111	120	131	141	166
EER		3.14	3.00	3.09	3.06	3.04	3.04
ESEER		3.86	3.73	3.74	3.66	3.65	3.87
IPLV		4.48	4.38	4.37	4.37	4.28	4.83
CASING							
Colour *		IW	IW	IW	IW	IW	IW
Material *		GPSS	GPSS	GPSS	GPSS	GPSS	GPSS
DIMENSIONS							
Height	mm	2540	2540	2540	2540	2540	2540
Width	mm	2258	2258	2258	2258	2258	2258
Length	mm	3230	3230	4130	4130	4130	4130
WEIGHT							
Unit Weight	kg	3061	3061	4104	4114	4124	4724
Operating Weight	kg	3161	3161	4274	4284	4294	4894
WATER HEAT EXCHANGER							
Type *		S&T	S&T	S&T	S&T	S&T	S&T
Water Volume	l	89	89	181	175	164	164
Water flow rate	l/s	13.9	16.0	17.9	19.2	20.6	24.2
Water pressure drop	kPa	28.5	31.1	42.0	47.3	39.5	30.5
Insulation material *		CC	CC	CC	CC	CC	CC
AIR HEAT EXCHANGER							
Type *		MCH	MCH	MCH	MCH	MCH	MCH
FAN							
Type *		ON-OFF (DPT)	ON-OFF (DPT)	ON-OFF (DPT)	ON-OFF (DPT)	ON-OFF (DPT)	ON-OFF (DPT)
Drive *		On/Off	On/Off	On/Off	On/Off	On/Off	On/Off
Diameter	mm	800	800	800	800	800	800
Nominal air flow	l/s	33129	33129	44172	44172	44172	44172
Quantity	No.	6	6	8	8	8	8
Speed	rpm	900	900	900	900	900	900
Motor input	kW	10.0	10.0	13.4	13.4	13.4	13.4
COMPRESSOR							
Type		Asymm Single Screw	Asymm Single Screw	Asymm Single Screw	Asymm Single Screw	Asymm Single Screw	Asymm Single Screw
Oil charge	l	26.0	26.0	26.0	26.0	26.0	32.0
Quantity	No.	2	2	2	2	2	2
SOUND LEVEL**							
Sound Power - Cooling	dB(A)	94	94	95	95	95	97
Sound Pressure level@1m distance - Cooling	dB(A)	74	74	75	75	75	77
REFRIGERANT CIRCUIT							
Refrigerant type		R134a	R134a	R134a	R134a	R134a	R134a
Refrigerant charge	kg	50	50	55	56	58	58
N. of circuits	No.	2	2	2	2	2	2
PIPING CONNECTIONS							
Evaporator water inlet/outlet	mm	114.3	114.3	139.7	139.7	139.7	139.7

All the performances (Cooling capacity, unit power input in cooling and EER) are based on the following conditions: evaporator 12.0/7.0°C; ambient 35.0°C, unit at full load operation; operating fluid: Water ; fouling factor = 0.

(* IW: Ivory White; GPSS: Galvanized and Painted Steel Sheet; PHE: Plate Heat Exchanger; S&T: Single Pass Shell & Tube; MCH: Microchannel; CC: Closed Cell; DPT: Direct Propeller Type; DOL: Direct On Line - VFD: Inverter - BRS: Brushless

(**) Sound power level (referred to evaporator 12/7°C, ambient 35°C full load operation) are measured in accordance with ISO 9614 and Eurovent 8/1 for Eurovent certified units. The certification refers only to the overall sound power level, the sound pressure is calculated from the sound power level and are for information only and not considered binding.

The minimum capacity indicated is referred to unit operating at standard Eurovent conditions. Dimensions and weights are for indication only and not considered binding. Before designing the installation, consult the official drawings available from the factory at request. All the data are referred to standard unit without options. Data are subject to change without notice.

EWAD~T-SLB

MODEL		EWAD520T-SL B2	EWAD580T-SL B2	EWAD700T-SL B2	EWAD800T-SL B2	EWAD940T-SL B2	EWADC10T-SL B2
COOLING PERFORMANCE							
Capacity - Cooling	kW	523	576	701	810	936	1.000
Capacity control - Type		Stepless	Stepless	Stepless	Stepless	Stepless	Stepless
Capacity control - Minimum capacity	%	12.5	12.5	12.5	12.5	12.5	12.5
Unit power input - Cooling	kW	171	189	234	266	308	340
EER		3.06	3.04	3.00	3.04	3.04	2.93
ESEER		3.95	4.05	3.87	3.89	3.82	3.89
IPLV		5.38	5.49	4.93	4.55	4.69	4.61
CASING							
Colour *		IW	IW	IW	IW	IW	IW
Material *		GPSS	GPSS	GPSS	GPSS	GPSS	GPSS
DIMENSIONS							
Height	mm	2540	2540	2537	2537	2537	2537
Width	mm	2258	2258	2282	2282	2282	2282
Length	mm	5030	5030	5976	5976	6876	6876
WEIGHT							
Unit Weight	kg	4860	4860	5527	5525	5858	5858
Operating Weight	kg	5030	5030	5825	5825	6188	6188
WATER HEAT EXCHANGER							
Type *		S&T	S&T	S&T	S&T	S&T	S&T
Water Volume	l	170	164	315	240	289	289
Water flow rate	l/s	25.0	27.6	33.6	38.7	44.8	47.8
Water pressure drop	kPa	43.6	60.4	51.4	32.4	39.5	44.7
Insulation material *		CC	CC	CC	CC	CC	CC
AIR HEAT EXCHANGER							
Type *		MCH	MCH	MCH	MCH	MCH	MCH
FAN							
Type *		ON-OFF (DPT)	ON-OFF (DPT)	ON-OFF (DPT)	ON-OFF (DPT)	ON-OFF (DPT)	ON-OFF (DPT)
Drive *		On/Off	On/Off	On/Off	On/Off	On/Off	On/Off
Diameter	mm	800	800	800	800	800	800
Nominal air flow	l/s	55214	55214	66257	66257	77300	77300
Quantity	No.	10	10	12	12	14	14
Speed	rpm	900	900	900	900	900	900
Motor input	kW	16.7	16.7	20.0	20.0	23.4	23.4
COMPRESSOR							
Type		Asymm Single Screw	Asymm Single Screw	Asymm Single Screw	Asymm Single Screw	Asymm Single Screw	Asymm Single Screw
Oil charge	l	32.0	32.0	34.0	34.0	42.0	42.0
Quantity	No.	2	2	2	2	2	2
SOUND LEVEL**							
Sound Power - Cooling	dB(A)	97	97	96	96	97	98
Sound Pressure level@ 1m distance - Cooling	dB(A)	77	77	75	75	76	77
REFRIGERANT CIRCUIT							
Refrigerant type		R134a	R134a	R134a	R134a	R134a	R134a
Refrigerant charge	kg	66	67	93.6	93.6	109.2	109.2
N. of circuits	No.	2	2	2	2	2	2
PIPING CONNECTIONS							
Evaporator water inlet/outlet	mm	139.7	139.7	168.3	168.3	168.3	168.3

All the performances (Cooling capacity, unit power input in cooling and EER) are based on the following conditions: evaporator 12.0/7.0°C; ambient 35.0°C, unit at full load operation; operating fluid: Water ; fouling factor = 0.

(*) IW: Ivory White; GPSS: Galvanized and Painted Steel Sheet; PHE: Plate Heat Exchanger; S&T: Single Pass Shell & Tube; MCH: Microchannel; CC: Closed Cell; DPT: Direct Propeller Type; DOL: Direct On Line - VFD: Inverter - BRS: Brushless

(**) Sound power level (referred to evaporator 12/7°C, ambient 35°C full load operation) are measured in accordance with ISO 9614 and Eurovent 8/1 for Eurovent certified units. The certification refers only to the overall sound power level, the sound pressure is calculated from the sound power level and are for information only and not considered binding.

The minimum capacity indicated is referred to unit operating at standard Eurovent conditions. Dimensions and weights are for indication only and not considered binding. Before designing the installation, consult the official drawings available from the factory at request. All the data are referred to standard unit without options. Data are subject to change without notice.

EWAD~T-SLB

MODEL		EWADH10T-SL B2	EWADC11T-SL B2	EWADH12T-SL B2	EWADH13T-SL B2	EWADH14T-SL B2	EWADH15T-SL B3
COOLING PERFORMANCE							
Capacity - Cooling	kW	1.052	1.136	1.268	1.353	1.457	1.579
Capacity control - Type		Stepless	Stepless	Stepless	Stepless	Stepless	Stepless
Capacity control - Minimum capacity	%	12.5	12.5	12.5	12.5	12.5	12.5
Unit power input - Cooling	kW	362	387	438	464	490	534
EER		2.90	2.93	2.89	2.91	2.97	2.96
ESEER		3.74	3.77	3.77	3.79	3.80	3.89
IPLV		4.41	4.46	4.46	4.50	4.53	4.58
CASING							
Colour *		IW	IW	IW	IW	IW	IW
Material *		GPSS	GPSS	GPSS	GPSS	GPSS	GPSS
DIMENSIONS							
Height	mm	2537	2537	2537	2537	2537	2537
Width	mm	2282	2282	2282	2282	2282	2282
Length	mm	6876	7776	7776	8676	9576	10509
WEIGHT							
Unit Weight	kg	6229	6520	6780	8084	8426	9938
Operating Weight	kg	6710	6981	7272	8554	8887	10460
WATER HEAT EXCHANGER							
Type *		S&T	S&T	S&T	S&T	S&T	S&T
Water Volume	l	518	502	492	470	461	522
Water flow rate	l/s	50.3	54.3	60.7	64.7	69.8	75.5
Water pressure drop	kPa	41.6	32.7	34.2	44.5	61.3	43.8
Insulation material *		CC	CC	CC	CC	CC	CC
AIR HEAT EXCHANGER							
Type *		MCH	MCH	MCH	MCH	MCH	MCH
FAN							
Type *		ON-OFF (DPT)	ON-OFF (DPT)	ON-OFF (DPT)	ON-OFF (DPT)	ON-OFF (DPT)	ON-OFF (DPT)
Drive *		On/Off	On/Off	On/Off	On/Off	On/Off	On/Off
Diameter	mm	800	800	800	800	800	800
Nominal air flow	l/s	77300	88343	88343	99386	110429	121472
Quantity	No.	14	16	16	18	20	22
Speed	rpm	900	900	900	900	900	900
Motor input	kW	23.4	26.7	26.7	30.1	33.4	36.7
COMPRESSOR							
Type		Asymm Single Screw	Asymm Single Screw	Asymm Single Screw	Asymm Single Screw	Asymm Single Screw	Asymm Single Screw
Oil charge	l	42.0	42.0	50.0	50.0	50.0	75.0
Quantity	No.	2	2	2	2	2	3
SOUND LEVEL**							
Sound Power - Cooling	dB(A)	97	98	98	98	98	98
Sound Pressure level@1m distance - Cooling	dB(A)	76	76	76	76	76	76
REFRIGERANT CIRCUIT							
Refrigerant type		R134a	R134a	R134a	R134a	R134a	R134a
Refrigerant charge	kg	109.2	124.8	124.8	140.4	156	172
N. of circuits	No.	2	2	2	2	2	3
PIPING CONNECTIONS							
Evaporator water inlet/outlet	mm	219.1	219.1	219.1	219.1	219.1	219.1

All the performances (Cooling capacity, unit power input in cooling and EER) are based on the following conditions: evaporator 12.0/7.0°C; ambient 35.0°C, unit at full load operation; operating fluid: Water ; fouling factor = 0.

(*) IW: Ivory White; GPSS: Galvanized and Painted Steel Sheet; PHE: Plate Heat Exchanger; S&T: Single Pass Shell & Tube; MCH: Microchannel; CC: Closed Cell; DPT: Direct Propeller Type; DOL: Direct On Line - VFD: Inverter - BRS: Brushless

(**) Sound power level (referred to evaporator 12/7°C, ambient 35°C full load operation) are measured in accordance with ISO 9614 and Eurovent 8/1 for Eurovent certified units. The certification refers only to the overall sound power level, the sound pressure is calculated from the sound power level and are for information only and not considered binding.

The minimum capacity indicated is referred to unit operating at standard Eurovent conditions. Dimensions and weights are for indication only and not considered binding. Before designing the installation, consult the official drawings available from the factory at request. All the data are referred to standard unit without options. Data are subject to change without notice.

EWAD~T-SLB

MODEL		EWADH16T-SL B3	EWADC17T-SL B3	EWADH18T-SL B3	EWADC19T-SL B3	EWADC20T-SL B3	EWADC21T-SL B3
COOLING PERFORMANCE							
Capacity - Cooling	kW	1.684	1.762	1.871	1.967	2.065	2.148
Capacity control - Type		Stepless	Stepless	Stepless	Stepless	Stepless	Stepless
Capacity control - Minimum capacity	%	12.5	12.5	12.5	12.5	12.5	12.5
Unit power input - Cooling	kW	563	605	654	682	710	735
EER		2.99	2.91	2.86	2.88	2.91	2.92
ESEER		3.93	3.88	3.73	3.71	3.66	3.71
IPLV		4.61	4.54	4.45	4.46	4.40	4.53
CASING							
Colour *		IW	IW	IW	IW	IW	IW
Material *		GPSS	GPSS	GPSS	GPSS	GPSS	GPSS
DIMENSIONS							
Height	mm	2537	2537	2537	2537	2537	2537
Width	mm	2282	2282	2282	2282	2282	2282
Length	mm	11409	11409	11409	12309	13209	14109
WEIGHT							
Unit Weight	kg	10575	10575	10636	10902	11202	11422
Operating Weight	kg	11446	11446	11589	11855	12237	12457
WATER HEAT EXCHANGER							
Type *		S&T	S&T	S&T	S&T	S&T	S&T
Water Volume	l	871	871	953	953	1035	1035
Water flow rate	l/s	80.6	84.4	89.6	94.2	98.9	102
Water pressure drop	kPa	49.3	53.5	56.4	64.5	64.8	69.6
Insulation material *		CC	CC	CC	CC	CC	CC
AIR HEAT EXCHANGER							
Type *		MCH	MCH	MCH	MCH	MCH	MCH
FAN							
Type *		ON-OFF (DPT)	ON-OFF (DPT)	ON-OFF (DPT)	ON-OFF (DPT)	ON-OFF (DPT)	ON-OFF (DPT)
Drive *		On/Off	On/Off	On/Off	On/Off	On/Off	On/Off
Diameter	mm	800	800	800	800	800	800
Nominal air flow	l/s	132515	132515	132515	143557	154600	165643
Quantity	No.	24	24	24	26	28	30
Speed	rpm	900	900	900	900	900	900
Motor input	kW	40.1	40.1	40.1	43.4	46.8	50.1
COMPRESSOR							
Type		Asymm Single Screw	Asymm Single Screw	Asymm Single Screw	Asymm Single Screw	Asymm Single Screw	Asymm Single Screw
Oil charge	l	75.0	75.0	75.0	75.0	75.0	75.0
Quantity	No.	3	3	3	3	3	3
SOUND LEVEL**							
Sound Power - Cooling	dB(A)	100	100	100	100	100	100
Sound Pressure level@1m distance - Cooling	dB(A)	77	77	77	77	77	77
REFRIGERANT CIRCUIT							
Refrigerant type		R134a	R134a	R134a	R134a	R134a	R134a
Refrigerant charge	kg	187	187	187	203	218	234
N. of circuits	No.	3	3	3	3	3	3
PIPING CONNECTIONS							
Evaporator water inlet/outlet	mm	273	273	273	273	273	273

All the performances (Cooling capacity, unit power input in cooling and EER) are based on the following conditions: evaporator 12.0/7.0°C; ambient 35.0°C, unit at full load operation; operating fluid: Water ; fouling factor = 0.

(*) IW: Ivory White; GPSS: Galvanized and Painted Steel Sheet; PHE: Plate Heat Exchanger; S&T: Single Pass Shell & Tube; MCH: Microchannel; CC: Closed Cell; DPT: Direct Propeller Type; DOL: Direct On Line - VFD: Inverter - BRS: Brushless

(**) Sound power level (referred to evaporator 12/7°C, ambient 35°C full load operation) are measured in accordance with ISO 9614 and Eurovent 8/1 for Eurovent certified units. The certification refers only to the overall sound power level, the sound pressure is calculated from the sound power level and are for information only and not considered binding.

The minimum capacity indicated is referred to unit operating at standard Eurovent conditions. Dimensions and weights are for indication only and not considered binding. Before designing the installation, consult the official drawings available from the factory at request. All the data are referred to standard unit without options. Data are subject to change without notice.

EWAD~T-SRB

MODEL		EWAD700T-SR B2	EWAD800T-SR B2	EWAD940T-SR B2	EWADC10T-SR B2	EWADH10T-SR B2	EWADC11T-SR B2
COOLING PERFORMANCE							
Capacity - Cooling	kW	685	787	910	967	1.014	1.099
Capacity control - Type		Stepless	Stepless	Stepless	Stepless	Stepless	Stepless
Capacity control - Minimum capacity	%	12.5	12.5	12.5	12.5	12.5	12.5
Unit power input - Cooling	kW	236	270	314	351	373	398
EER		2.89	2.91	2.89	2.76	2.72	2.76
ESEER		3.89	3.90	3.85	3.79	3.73	3.76
IPLV		4.90	4.56	4.57	4.45	4.39	4.44
CASING							
Colour *		IW	IW	IW	IW	IW	IW
Material *		GPSS	GPSS	GPSS	GPSS	GPSS	GPSS
DIMENSIONS							
Height	mm	2537	2537	2537	2537	2537	2537
Width	mm	2282	2282	2282	2282	2282	2282
Length	mm	5976	5976	6876	6876	6876	7776
WEIGHT							
Unit Weight	kg	5847	5845	6178	6178	6549	6840
Operating Weight	kg	6145	6145	6508	6508	7030	7301
WATER HEAT EXCHANGER							
Type *		S&T	S&T	S&T	S&T	S&T	S&T
Water Volume	l	315	240	289	289	518	502
Water flow rate	l/s	32.8	37.6	43.5	46.3	48.5	52.6
Water pressure drop	kPa	49.2	30.7	37.5	42.2	39.0	30.8
Insulation material *		CC	CC	CC	CC	CC	CC
AIR HEAT EXCHANGER							
Type *		MCH	MCH	MCH	MCH	MCH	MCH
FAN							
Type *		ON-OFF (DPT)	ON-OFF (DPT)	ON-OFF (DPT)	ON-OFF (DPT)	ON-OFF (DPT)	ON-OFF (DPT)
Drive *		On/Off	On/Off	On/Off	On/Off	On/Off	On/Off
Diameter	mm	800	800	800	800	800	800
Nominal air flow	l/s	52172	52172	60868	60868	60868	69563
Quantity	No.	12	12	14	14	14	16
Speed	rpm	700	700	700	700	700	700
Motor input	kW	10.4	10.4	12.2	12.2	12.2	13.9
COMPRESSOR							
Type		Asymm Single Screw	Asymm Single Screw	Asymm Single Screw	Asymm Single Screw	Asymm Single Screw	Asymm Single Screw
Oil charge	l	34.0	34.0	42.0	42.0	42.0	42.0
Quantity	No.	2	2	2	2	2	2
SOUND LEVEL**							
Sound Power - Cooling	dB(A)	91	91	91	92	92	92
Sound Pressure level@1m distance - Cooling	dB(A)	70	70	70	71	71	70
REFRIGERANT CIRCUIT							
Refrigerant type		R134a	R134a	R134a	R134a	R134a	R134a
Refrigerant charge	kg	93.6	93.6	109.2	109.2	109.2	124.8
N. of circuits	No.	2	2	2	2	2	2
PIPING CONNECTIONS							
Evaporator water inlet/outlet	mm	168.3	168.3	168.3	168.3	219.1	219.1

All the performances (Cooling capacity, unit power input in cooling and EER) are based on the following conditions: evaporator 12.0/7.0°C; ambient 35.0°C, unit at full load operation; operating fluid: Water ; fouling factor = 0.

(* IW: Ivory White; GPSS: Galvanized and Painted Steel Sheet; PHE: Plate Heat Exchanger; S&T: Single Pass Shell & Tube; MCH: Microchannel; CC: Closed Cell; DPT: Direct Propeller Type; DOL: Direct On Line - VFD: Inverter - BRS: Brushless

(**) Sound power level (referred to evaporator 12/7°C, ambient 35°C full load operation) are measured in accordance with ISO 9614 and Eurovent 8/1 for Eurovent certified units. The certification refers only to the overall sound power level, the sound pressure is calculated from the sound power level and are for information only and not considered binding.

The minimum capacity indicated is referred to unit operating at standard Eurovent conditions. Dimensions and weights are for indication only and not considered binding. Before designing the installation, consult the official drawings available from the factory at request. All the data are referred to standard unit without options. Data are subject to change without notice.

EWAD~T-SRB

MODEL		EWADH12T-SR B2	EWADH13T-SR B2	EWADH14T-SR B2	EWADH15T-SR B3	EWADH16T-SR B3	EWADC17T-SR B3
COOLING PERFORMANCE							
Capacity - Cooling	kW	1.217	1.303	1.408	1.525	1.632	1.702
Capacity control - Type		Stepless	Stepless	Stepless	Stepless	Stepless	Stepless
Capacity control - Minimum capacity	%	12.5	12.5	12.5	12.5	12.5	12.5
Unit power input - Cooling	kW	453	478	504	547	575	622
EER		2.68	2.72	2.79	2.79	2.84	2.74
ESEER		3.75	3.77	3.81	3.89	3.94	3.88
IPLV		4.43	4.49	4.49	4.60	4.62	4.54
CASING							
Colour *		IW	IW	IW	IW	IW	IW
Material *		GPSS	GPSS	GPSS	GPSS	GPSS	GPSS
DIMENSIONS							
Height	mm	2537	2537	2537	2537	2537	2537
Width	mm	2282	2282	2282	2282	2282	2282
Length	mm	7776	8676	9576	10509	11409	11409
WEIGHT							
Unit Weight	kg	7100	8404	8746	10588	11225	11225
Operating Weight	kg	7592	8874	9207	11110	12096	12096
WATER HEAT EXCHANGER							
Type *		S&T	S&T	S&T	S&T	S&T	S&T
Water Volume	l	492	470	461	522	871	871
Water flow rate	l/s	58.2	62.3	67.4	73.0	78.1	81.5
Water pressure drop	kPa	31.7	41.6	57.7	41.1	46.5	50.2
Insulation material *		CC	CC	CC	CC	CC	CC
AIR HEAT EXCHANGER							
Type *		MCH	MCH	MCH	MCH	MCH	MCH
FAN							
Type *		ON-OFF (DPT)	ON-OFF (DPT)	ON-OFF (DPT)	ON-OFF (DPT)	ON-OFF (DPT)	ON-OFF (DPT)
Drive *		On/Off	On/Off	On/Off	On/Off	On/Off	On/Off
Diameter	mm	800	800	800	800	800	800
Nominal air flow	l/s	69563	78258	86954	95649	104344	104344
Quantity	No.	16	18	20	22	24	24
Speed	rpm	700	700	700	700	700	700
Motor input	kW	13.9	15.7	17.4	19.1	20.9	20.9
COMPRESSOR							
Type		Asymm Single Screw	Asymm Single Screw	Asymm Single Screw	Asymm Single Screw	Asymm Single Screw	Asymm Single Screw
Oil charge	l	50.0	50.0	50.0	75.0	75.0	75.0
Quantity	No.	2	2	2	3	3	3
SOUND LEVEL**							
Sound Power - Cooling	dB(A)	92	93	93	95	95	95
Sound Pressure level@1m distance - Cooling	dB(A)	70	71	71	72	72	72
REFRIGERANT CIRCUIT							
Refrigerant type		R134a	R134a	R134a	R134a	R134a	R134a
Refrigerant charge	kg	124.8	140.4	156	172	187	187
N. of circuits	No.	2	2	2	3	3	3
PIPING CONNECTIONS							
Evaporator water inlet/outlet	mm	219.1	219.1	219.1	219.1	273	273

All the performances (Cooling capacity, unit power input in cooling and EER) are based on the following conditions: evaporator 12.0/7.0°C; ambient 35.0°C, unit at full load operation; operating fluid: Water ; fouling factor = 0.

(*) IW: Ivory White; GPSS: Galvanized and Painted Steel Sheet; PHE: Plate Heat Exchanger; S&T: Single Pass Shell & Tube; MCH: Microchannel; CC: Closed Cell; DPT: Direct Propeller Type; DOL: Direct On Line - VFD: Inverter - BRS: Brushless

(**) Sound power level (referred to evaporator 12/7°C, ambient 35°C full load operation) are measured in accordance with ISO 9614 and Eurovent 8/1 for Eurovent certified units. The certification refers only to the overall sound power level, the sound pressure is calculated from the sound power level and are for information only and not considered binding.

The minimum capacity indicated is referred to unit operating at standard Eurovent conditions. Dimensions and weights are for indication only and not considered binding. Before designing the installation, consult the official drawings available from the factory at request. All the data are referred to standard unit without options. Data are subject to change without notice.

EWAD~T-SRB

MODEL		EWADH18T-SR B3	EWADC19T-SR B3	EWADC20T-SR B3	EWADC21T-SR B3
COOLING PERFORMANCE					
Capacity - Cooling	kW	1.798	1.894	1,992	2.077
Capacity control - Type		Stepless	Stepless	Stepless	Stepless
Capacity control - Minimum capacity	%	12.5	12.5	12.5	12.5
Unit power input - Cooling	kW	675	703	730	755
EER		2.66	2.69	2.73	2.75
ESEER		3.72	3.70	3.65	3.71
IPLV		4.44	4.46	4.40	4.53
CASING					
Colour *		IW	IW	IW	IW
Material *		GPSS	GPSS	GPSS	GPSS
DIMENSIONS					
Height	mm	2537	2537	2537	2537
Width	mm	2282	2282	2282	2282
Length	mm	11409	12309	13209	14109
WEIGHT					
Unit Weight	kg	11286	11552	11852	12072
Operating Weight	kg	12239	12505	12887	13107
WATER HEAT EXCHANGER					
Type *		S&T	S&T	S&T	S&T
Water Volume	l	953	953	1035	1035
Water flow rate	l/s	86.1	90.7	95.4	99.5
Water pressure drop	kPa	52.5	60.2	60.7	65.5
Insulation material *		CC	CC	CC	CC
AIR HEAT EXCHANGER					
Type *		MCH	MCH	MCH	MCH
FAN					
Type *		ON-OFF (DPT)	ON-OFF (DPT)	ON-OFF (DPT)	ON-OFF (DPT)
Drive *		On/Off	On/Off	On/Off	On/Off
Diameter	mm	800	800	800	800
Nominal air flow	l/s	104344	113040	121735	130431
Quantity	No.	24	26	28	30
Speed	rpm	700	700	700	700
Motor input	kW	20.9	22.6	24.4	26.1
COMPRESSOR					
Type		Asymm Single Screw	Asymm Single Screw	Asymm Single Screw	Asymm Single Screw
Oil charge	l	75.0	75.0	75.0	75.0
Quantity	No.	3	3	3	3
SOUND LEVEL**					
Sound Power - Cooling	dB(A)	95	96	96	96
Sound Pressure level@1m distance - Cooling	dB(A)	73	73	73	73
REFRIGERANT CIRCUIT					
Refrigerant type		R134a	R134a	R134a	R134a
Refrigerant charge	kg	187	203	218	234
N. of circuits	No.	3	3	3	3
PIPING CONNECTIONS					
Evaporator water inlet/outlet	mm	273	273	273	273

All the performances (Cooling capacity, unit power input in cooling and EER) are based on the following conditions: evaporator 12.0/7.0°C; ambient 35.0°C, unit at full load operation; operating fluid: Water ; fouling factor = 0.

(*) IW: Ivory White; GPSS: Galvanized and Painted Steel Sheet; PHE: Plate Heat Exchanger; S&T: Single Pass Shell & Tube; MCH: Microchannel; CC: Closed Cell; DPT: Direct Propeller Type; DOL: Direct On Line - VFD: Inverter - BRS: Brushless

(**) Sound power level (referred to evaporator 12/7°C, ambient 35°C full load operation) are measured in accordance with ISO 9614 and Eurovent 8/1 for Eurovent certified units. The certification refers only to the overall sound power level, the sound pressure is calculated from the sound power level and are for information only and not considered binding.

The minimum capacity indicated is referred to unit operating at standard Eurovent conditions. Dimensions and weights are for indication only and not considered binding. Before designing the installation, consult the official drawings available from the factory at request. All the data are referred to standard unit without options. Data are subject to change without notice.

EWAD~T-XSB

MODEL		EWAD350T- XS B2	EWAD380T- XS B2	EWAD400T- XS B2	EWAD420T- XS B2	EWAD440T- XS B2	EWAD490T- XS B2
COOLING PERFORMANCE							
Capacity - Cooling	kW	351	377	398	415	438	492
Capacity control - Type		Stepless	Stepless	Stepless	Stepless	Stepless	Stepless
Capacity control - Minimum capacity	%	12.5	12.5	12.5	12.5	12.5	12.5
Unit power input - Cooling	kW	106	114	121	128	138	159
EER		3.31	3.28	3.28	3.22	3.16	3.09
ESEER		4.01	3.96	4.15	3.97	3.96	4.11
IPLV		4.60	4.55	4.76	4.61	4.57	5.46
CASING							
Colour *		IW	IW	IW	IW	IW	IW
Material *		GPSS	GPSS	GPSS	GPSS	GPSS	GPSS
DIMENSIONS							
Height	mm	2540	2540	2540	2540	2540	2540
Width	mm	2258	2258	2258	2258	2258	2258
Length	mm	4130	4130	5030	5030	5030	5030
WEIGHT							
Unit Weight	kg	4054	4064	4360	4360	4360	4860
Operating Weight	kg	4224	4234	4530	4530	4530	5030
WATER HEAT EXCHANGER							
Type *		S&T	S&T	S&T	S&T	S&T	S&T
Water Volume	l	134	129	129	170	170	170
Water flow rate	l/s	16.8	18.0	19.0	19.8	20.9	23.5
Water pressure drop	kPa	20.1	26.3	25.1	19.3	21.1	42.7
Insulation material *		CC	CC	CC	CC	CC	CC
AIR HEAT EXCHANGER							
Type *		MCH	MCH	MCH	MCH	MCH	MCH
FAN							
Type *		ON-OFF (DPT)	ON-OFF (DPT)	ON-OFF (DPT)	ON-OFF (DPT)	ON-OFF (DPT)	ON-OFF (DPT)
Drive *		On/Off	On/Off	On/Off	On/Off	On/Off	On/Off
Diameter	mm	800	800	800	800	800	800
Nominal air flow	l/s	44172	44172	55214	55214	55214	55214
Quantity	No.	8	8	10	10	10	10
Speed	rpm	900	900	900	900	900	900
Motor input	kW	13.4	13.4	16.7	16.7	16.7	16.7
COMPRESSOR							
Type		Asymm Single Screw	Asymm Single Screw	Asymm Single Screw	Asymm Single Screw	Asymm Single Screw	Asymm Single Screw
Oil charge	l	26.0	26.0	26.0	26.0	26.0	32.0
Quantity	No.	2	2	2	2	2	2
SOUND LEVEL**							
Sound Power - Cooling	dB(A)	98	98	98	98	98	101
Sound Pressure level@1m distance - Cooling	dB(A)	78	78	78	78	78	81
REFRIGERANT CIRCUIT							
Refrigerant type		R134a	R134a	R134a	R134a	R134a	R134a
Refrigerant charge	kg	52	54	65	66	66	66
N. of circuits	No.	2	2	2	2	2	2
PIPING CONNECTIONS							
Evaporator water inlet/outlet	mm	139.7	139.7	139.7	139.7	139.7	139.7

All the performances (Cooling capacity, unit power input in cooling and EER) are based on the following conditions: evaporator 12.0/7.0°C; ambient 35.0°C, unit at full load operation; operating fluid: Water ; fouling factor = 0.

(*) IW: Ivory White; GPSS: Galvanized and Painted Steel Sheet; PHE: Plate Heat Exchanger; S&T: Single Pass Shell & Tube; MCH: Microchannel; CC: Closed Cell; DPT: Direct Propeller Type; DOL: Direct On Line - VFD: Inverter - BRS: Brushless

(**) Sound power level (referred to evaporator 12/7°C, ambient 35°C full load operation) are measured in accordance with ISO 9614 and Eurovent 8/1 for Eurovent certified units. The certification refers only to the overall sound power level, the sound pressure is calculated from the sound power level and are for information only and not considered binding.

The minimum capacity indicated is referred to unit operating at standard Eurovent conditions. Dimensions and weights are for indication only and not considered binding. Before designing the installation, consult the official drawings available from the factory at request. All the data are referred to standard unit without options. Data are subject to change without notice.

EWAD~T-XSB

MODEL		EWAD540T- XS B2	EWAD570T- XS B2	EWAD730T- XS B2	EWAD820T- XS B2	EWAD950T- XS B2	EWADC10T- XS B2
COOLING PERFORMANCE							
Capacity - Cooling	kW	541	565	725	832	943	1.008
Capacity control - Type		Stepless	Stepless	Stepless	Stepless	Stepless	Stepless
Capacity control - Minimum capacity	%	12.5	12.5	12.5	12.5	12.5	12.5
Unit power input - Cooling	kW	166	177	234	267	299	333
EER		3.25	3.18	3.09	3.11	3.15	3.03
ESEER		4.13	4.05	3.94	3.88	4.05	3.95
IPLV		5.49	5.30	4.93	4.55	5.17	4.69
CASING							
Colour *		IW	IW	IW	IW	IW	IW
Material *		GPSS	GPSS	GPSS	GPSS	GPSS	GPSS
DIMENSIONS							
Height	mm	2540	2540	2537	2537	2537	2537
Width	mm	2258	2258	2282	2282	2282	2282
Length	mm	5878	5878	5976	5976	7776	7776
WEIGHT							
Unit Weight	kg	5397	5387	5315	5525	6121	6121
Operating Weight	kg	5567	5557	5604	5825	6451	6451
WATER HEAT EXCHANGER							
Type *		S&T	S&T	S&T	S&T	S&T	S&T
Water Volume	l	164	170	315	232	289	289
Water flow rate	l/s	25.9	27.0	34.7	39.8	45.1	48.3
Water pressure drop	kPa	34.1	33.4	33.0	36.8	40.8	46.0
Insulation material *		CC	CC	CC	CC	CC	CC
AIR HEAT EXCHANGER							
Type *		MCH	MCH	MCH	MCH	MCH	MCH
FAN							
Type *		ON-OFF (DPT)	ON-OFF (DPT)	ON-OFF (DPT)	ON-OFF (DPT)	ON-OFF (DPT)	ON-OFF (DPT)
Drive *		On/Off	On/Off	On/Off	On/Off	On/Off	On/Off
Diameter	mm	800	800	800	800	800	800
Nominal air flow	l/s	66257	66257	66257	66257	88343	88343
Quantity	No.	12	12	12	12	16	16
Speed	rpm	900	900	900	900	900	900
Motor input	kW	20.0	20.0	20.0	20.0	26.7	26.7
COMPRESSOR							
Type		Asymm Single Screw	Asymm Single Screw	Asymm Single Screw	Asymm Single Screw	Asymm Single Screw	Asymm Single Screw
Oil charge	l	32.0	32.0	34.0	34.0	42.0	42.0
Quantity	No.	2	2	2	2	2	2
SOUND LEVEL**							
Sound Power - Cooling	dB(A)	101	101	99	99	100	100
Sound Pressure level@1m distance - Cooling	dB(A)	81	81	78	78	78	78
REFRIGERANT CIRCUIT							
Refrigerant type		R134a	R134a	R134a	R134a	R134a	R134a
Refrigerant charge	kg	72	72	93.6	93.6	124.8	124.8
N. of circuits	No.	2	2	2	2	2	2
PIPING CONNECTIONS							
Evaporator water inlet/outlet	mm	139.7	139.7	168.3	168.3	168.3	168.3

All the performances (Cooling capacity, unit power input in cooling and EER) are based on the following conditions: evaporator 12.0/7.0°C; ambient 35.0°C, unit at full load operation; operating fluid: Water ; fouling factor = 0.

(*) IW: Ivory White; GPSS: Galvanized and Painted Steel Sheet; PHE: Plate Heat Exchanger; S&T: Single Pass Shell & Tube; MCH: Microchannel; CC: Closed Cell; DPT: Direct Propeller Type; DOL: Direct On Line - VFD: Inverter - BRS: Brushless

(**) Sound power level (referred to evaporator 12/7°C, ambient 35°C full load operation) are measured in accordance with ISO 9614 and Eurovent 8/1 for Eurovent certified units. The certification refers only to the overall sound power level, the sound pressure is calculated from the sound power level and are for information only and not considered binding.

The minimum capacity indicated is referred to unit operating at standard Eurovent conditions. Dimensions and weights are for indication only and not considered binding. Before designing the installation, consult the official drawings available from the factory at request. All the data are referred to standard unit without options. Data are subject to change without notice.

EWAD~T-XSB

MODEL		EWADH10T- XS B2	EWADH11T- XS B2	EWADC13T- XS B2	EWADH13T- XS B2	EWADC14T- XS B2	EWADH15T- XS B3
COOLING PERFORMANCE							
Capacity - Cooling	kW	1.077	1.165	1.308	1.390	1.454	1.606
Capacity control - Type		Stepless	Stepless	Stepless	Stepless	Stepless	Stepless
Capacity control - Minimum capacity	%	12.5	12.5	12.5	12.5	12.5	12.5
Unit power input - Cooling	kW	347	374	421	447	481	520
EER		3.10	3.11	3.11	3.11	3.02	3.09
ESEER		3.89	3.88	3.95	3.94	3.87	3.94
IPLV		4.63	4.66	4.64	4.68	4.63	4.50
CASING							
Colour *		IW	IW	IW	IW	IW	IW
Material *		GPSS	GPSS	GPSS	GPSS	GPSS	GPSS
DIMENSIONS							
Height	mm	2537	2537	2537	2537	2537	2537
Width	mm	2282	2282	2282	2282	2282	2282
Length	mm	8676	9576	9576	10476	10476	11409
WEIGHT							
Unit Weight	kg	7798	8126	8386	8751	8765	10575
Operating Weight	kg	8259	8587	8878	9232	9235	11446
WATER HEAT EXCHANGER							
Type *		S&T	S&T	S&T	S&T	S&T	S&T
Water Volume	l	502	502	492	481	470	871
Water flow rate	l/s	51.6	55.8	62.6	66.5	69.6	76.9
Water pressure drop	kPa	51.9	60.5	36.2	40.4	50.8	45.2
Insulation material *		CC	CC	CC	CC	CC	CC
AIR HEAT EXCHANGER							
Type *		MCH	MCH	MCH	MCH	MCH	MCH
FAN							
Type *		ON-OFF (DPT)	ON-OFF (DPT)	ON-OFF (DPT)	ON-OFF (DPT)	ON-OFF (DPT)	ON-OFF (DPT)
Drive *		On/Off	On/Off	On/Off	On/Off	On/Off	On/Off
Diameter	mm	800	800	800	800	800	800
Nominal air flow	l/s	99386	110429	110429	121472	121472	132515
Quantity	No.	18	20	20	22	22	24
Speed	rpm	900	900	900	900	900	900
Motor input	kW	30.1	33.4	33.4	36.7	36.7	40.1
COMPRESSOR							
Type		Asymm Single Screw	Asymm Single Screw	Asymm Single Screw	Asymm Single Screw	Asymm Single Screw	Asymm Single Screw
Oil charge	l	42.0	42.0	50.0	50.0	50.0	75.0
Quantity	No.	2	2	2	2	2	3
SOUND LEVEL**							
Sound Power - Cooling	dB(A)	100	101	101	101	101	103
Sound Pressure level@1m distance - Cooling	dB(A)	78	79	79	79	79	80
REFRIGERANT CIRCUIT							
Refrigerant type		R134a	R134a	R134a	R134a	R134a	R134a
Refrigerant charge	kg	140.4	156	156	171.6	171.6	187
N. of circuits	No.	2	2	2	2	2	3
PIPING CONNECTIONS							
Evaporator water inlet/outlet	mm	219.1	219.1	219.1	219.1	219.1	273

All the performances (Cooling capacity, unit power input in cooling and EER) are based on the following conditions: evaporator 12.0/7.0°C; ambient 35.0°C, unit at full load operation; operating fluid: Water ; fouling factor = 0.

(*) IW: Ivory White; GPSS: Galvanized and Painted Steel Sheet; PHE: Plate Heat Exchanger; S&T: Single Pass Shell & Tube; MCH: Microchannel; CC: Closed Cell; DPT: Direct Propeller Type; DOL: Direct On Line - VFD: Inverter - BRS: Brushless

(**) Sound power level (referred to evaporator 12/7°C, ambient 35°C full load operation) are measured in accordance with ISO 9614 and Eurovent 8/1 for Eurovent certified units. The certification refers only to the overall sound power level, the sound pressure is calculated from the sound power level and are for information only and not considered binding.

The minimum capacity indicated is referred to unit operating at standard Eurovent conditions. Dimensions and weights are for indication only and not considered binding. Before designing the installation, consult the official drawings available from the factory at request. All the data are referred to standard unit without options. Data are subject to change without notice.

EWAD~T-XSB

MODEL		EWADH16T- XS B3	EWADC17T- XS B3	EWADH18T- XS B3	EWADC19T- XS B3	EWADC20T- XS B3
COOLING PERFORMANCE						
Capacity - Cooling	kW	1.705	1.836	1,952	2.027	2.088
Capacity control - Type		Stepless	Stepless	Stepless	Stepless	Stepless
Capacity control - Minimum capacity	%	12.5	12.5	12.5	12.5	12.5
Unit power input - Cooling	kW	552	589	624	662	699
EER		3.09	3.12	3.13	3.06	2.99
ESEER		3.84	3.88	3.97	3.92	3.93
IPLV		4.51	4.55	4.56	4.53	4.48
CASING						
Colour *		IW	IW	IW	IW	IW
Material *		GPSS	GPSS	GPSS	GPSS	GPSS
DIMENSIONS						
Height	mm	2537	2537	2537	2537	2537
Width	mm	2282	2282	2282	2282	2282
Length	mm	12309	13209	14109	14109	14109
WEIGHT						
Unit Weight	kg	10841	10711	10931	11451	11451
Operating Weight	kg	11712	11233	11453	12461	12461
WATER HEAT EXCHANGER						
Type *		S&T	S&T	S&T	S&T	S&T
Water Volume	l	871	522	522	1010	1010
Water flow rate	l/s	81.6	87.9	93.5	97.1	100
Water pressure drop	kPa	50.4	54.5	63.6	62.7	66.1
Insulation material *		CC	CC	CC	CC	CC
AIR HEAT EXCHANGER						
Type *		MCH	MCH	MCH	MCH	MCH
FAN						
Type *		ON-OFF (DPT)	ON-OFF (DPT)	ON-OFF (DPT)	ON-OFF (DPT)	ON-OFF (DPT)
Drive *		On/Off	On/Off	On/Off	On/Off	On/Off
Diameter	mm	800	800	800	800	800
Nominal air flow	l/s	143557	154600	165643	165643	165643
Quantity	No.	26	28	30	30	30
Speed	rpm	900	900	900	900	900
Motor input	kW	43.4	46.8	50.1	50.1	50.1
COMPRESSOR						
Type		Asymm Single Screw	Asymm Single Screw	Asymm Single Screw	Asymm Single Screw	Asymm Single Screw
Oil charge	l	75.0	75.0	75.0	75.0	75.0
Quantity	No.	3	3	3	3	3
SOUND LEVEL**						
Sound Power - Cooling	dB(A)	103	103	103	103	103
Sound Pressure level@1m distance - Cooling	dB(A)	80	79	79	80	80
REFRIGERANT CIRCUIT						
Refrigerant type		R134a	R134a	R134a	R134a	R134a
Refrigerant charge	kg	203	218	234	234	234
N. of circuits	No.	3	3	3	3	3
PIPING CONNECTIONS						
Evaporator water inlet/outlet	mm	273	273	273	273	273

All the performances (Cooling capacity, unit power input in cooling and EER) are based on the following conditions: evaporator 12.0/7.0°C; ambient 35.0°C, unit at full load operation; operating fluid: Water ; fouling factor = 0.

(* IW: Ivory White; GPSS: Galvanized and Painted Steel Sheet; PHE: Plate Heat Exchanger; S&T: Single Pass Shell & Tube; MCH: Microchannel; CC: Closed Cell; DPT: Direct Propeller Type; DOL: Direct On Line - VFD: Inverter - BRS: Brushless

(**) Sound power level (referred to evaporator 12/7°C, ambient 35°C full load operation) are measured in accordance with ISO 9614 and Eurovent 8/1 for Eurovent certified units. The certification refers only to the overall sound power level, the sound pressure is calculated from the sound power level and are for information only and not considered binding.

The minimum capacity indicated is referred to unit operating at standard Eurovent conditions. Dimensions and weights are for indication only and not considered binding. Before designing the installation, consult the official drawings available from the factory at request. All the data are referred to standard unit without options. Data are subject to change without notice.

EWAD~T-XLB

MODEL		EWAD350T-XL B2	EWAD380T-XL B2	EWAD400T-XL B2	EWAD420T-XL B2	EWAD440T-XL B2	EWAD490T-XL B2
COOLING PERFORMANCE							
Capacity - Cooling	kW	351	377	398	415	438	492
Capacity control - Type		Stepless	Stepless	Stepless	Stepless	Stepless	Stepless
Capacity control - Minimum capacity	%	12.5	12.5	12.5	12.5	12.5	12.5
Unit power input - Cooling	kW	106	114	121	128	138	159
EER		3.31	3.28	3.28	3.22	3.16	3.09
ESEER		4.01	3.96	4.15	3.97	3.96	4.11
IPLV		4.60	4.55	4.76	4.61	4.57	5.46
CASING							
Colour *		IW	IW	IW	IW	IW	IW
Material *		GPSS	GPSS	GPSS	GPSS	GPSS	GPSS
DIMENSIONS							
Height	mm	2540	2540	2540	2540	2540	2540
Width	mm	2258	2258	2258	2258	2258	2258
Length	mm	4130	4130	5030	5030	5030	5030
WEIGHT							
Unit Weight	kg	4054	4064	4360	4360	4360	4860
Operating Weight	kg	4224	4234	4530	4530	4530	5030
WATER HEAT EXCHANGER							
Type *		S&T	S&T	S&T	S&T	S&T	S&T
Water Volume	l	134	129	129	170	170	170
Water flow rate	l/s	16.8	18.0	19.0	19.8	20.9	23.5
Water pressure drop	kPa	20.1	26.3	25.1	19.3	21.1	42.7
Insulation material *		CC	CC	CC	CC	CC	CC
AIR HEAT EXCHANGER							
Type *		MCH	MCH	MCH	MCH	MCH	MCH
FAN							
Type *		ON-OFF (DPT)	ON-OFF (DPT)	ON-OFF (DPT)	ON-OFF (DPT)	ON-OFF (DPT)	ON-OFF (DPT)
Drive *		On/Off	On/Off	On/Off	On/Off	On/Off	On/Off
Diameter	mm	800	800	800	800	800	800
Nominal air flow	l/s	44172	44172	55214	55214	55214	55214
Quantity	No.	8	8	10	10	10	10
Speed	rpm	900	900	900	900	900	900
Motor input	kW	13.4	13.4	16.7	16.7	16.7	16.7
COMPRESSOR							
Type		Asymm Single Screw	Asymm Single Screw	Asymm Single Screw	Asymm Single Screw	Asymm Single Screw	Asymm Single Screw
Oil charge	l	26.0	26.0	26.0	26.0	26.0	32.0
Quantity	No.	2	2	2	2	2	2
SOUND LEVEL**							
Sound Power - Cooling	dB(A)	95	95	95	95	95	97
Sound Pressure level@1m distance - Cooling	dB(A)	75	75	75	75	75	77
REFRIGERANT CIRCUIT							
Refrigerant type		R134a	R134a	R134a	R134a	R134a	R134a
Refrigerant charge	kg	52	54	65	66	66	66
N. of circuits	No.	2	2	2	2	2	2
PIPING CONNECTIONS							
Evaporator water inlet/outlet	mm	139.7	139.7	139.7	139.7	139.7	139.7

All the performances (Cooling capacity, unit power input in cooling and EER) are based on the following conditions: evaporator 12.0/7.0°C; ambient 35.0°C, unit at full load operation; operating fluid: Water ; fouling factor = 0.

(*) IW: Ivory White; GPSS: Galvanized and Painted Steel Sheet; PHE: Plate Heat Exchanger; S&T: Single Pass Shell & Tube; MCH: Microchannel; CC: Closed Cell; DPT: Direct Propeller Type; DOL: Direct On Line - VFD: Inverter - BRS: Brushless

(**) Sound power level (referred to evaporator 12/7°C, ambient 35°C full load operation) are measured in accordance with ISO 9614 and Eurovent 8/1 for Eurovent certified units. The certification refers only to the overall sound power level, the sound pressure is calculated from the sound power level and are for information only and not considered binding.

The minimum capacity indicated is referred to unit operating at standard Eurovent conditions. Dimensions and weights are for indication only and not considered binding. Before designing the installation, consult the official drawings available from the factory at request. All the data are referred to standard unit without options. Data are subject to change without notice.

EWAD~T-XLB

MODEL		EWAD540T-XL B2	EWAD570T-XL B2	EWAD730T-XL B2	EWAD820T-XL B2	EWAD950T-XL B2	EWADC10T-XL B2
COOLING PERFORMANCE							
Capacity - Cooling	kW	541	565	725	832	943	1.008
Capacity control - Type		Stepless	Stepless	Stepless	Stepless	Stepless	Stepless
Capacity control - Minimum capacity	%	12.5	12.5	12.5	12.5	12.5	12.5
Unit power input - Cooling	kW	166	177	234	267	299	333
EER		3.25	3.18	3.09	3.11	3.15	3.03
ESEER		4.13	4.05	3.94	3.88	4.05	3.95
IPLV		5.49	5.30	4.93	4.55	5.17	4.69
CASING							
Colour *		IW	IW	IW	IW	IW	IW
Material *		GPSS	GPSS	GPSS	GPSS	GPSS	GPSS
DIMENSIONS							
Height	mm	2540	2540	2537	2537	2537	2537
Width	mm	2258	2258	2282	2282	2282	2282
Length	mm	5878	5878	5976	5976	7776	7776
WEIGHT							
Unit Weight	kg	5397	5387	5315	5525	6121	6121
Operating Weight	kg	5567	5557	5604	5825	6451	6451
WATER HEAT EXCHANGER							
Type *		S&T	S&T	S&T	S&T	S&T	S&T
Water Volume	l	164	170	315	232	289	289
Water flow rate	l/s	25.9	27.0	34.7	39.8	45.1	48.3
Water pressure drop	kPa	34.1	33.4	33.0	36.8	40.8	46.0
Insulation material *		CC	CC	CC	CC	CC	CC
AIR HEAT EXCHANGER							
Type *		MCH	MCH	MCH	MCH	MCH	MCH
FAN							
Type *		ON-OFF (DPT)	ON-OFF (DPT)	ON-OFF (DPT)	ON-OFF (DPT)	ON-OFF (DPT)	ON-OFF (DPT)
Drive *		On/Off	On/Off	On/Off	On/Off	On/Off	On/Off
Diameter	mm	800	800	800	800	800	800
Nominal air flow	l/s	66257	66257	66257	66257	88343	88343
Quantity	No.	12	12	12	12	16	16
Speed	rpm	900	900	900	900	900	900
Motor input	kW	20.0	20.0	20.0	20.0	26.7	26.7
COMPRESSOR							
Type		Asymm Single Screw	Asymm Single Screw	Asymm Single Screw	Asymm Single Screw	Asymm Single Screw	Asymm Single Screw
Oil charge	l	32.0	32.0	34.0	34.0	42.0	42.0
Quantity	No.	2	2	2	2	2	2
SOUND LEVEL**							
Sound Power - Cooling	dB(A)	97	97	97	97	98	98
Sound Pressure level@1m distance - Cooling	dB(A)	77	77	76	76	76	76
REFRIGERANT CIRCUIT							
Refrigerant type		R134a	R134a	R134a	R134a	R134a	R134a
Refrigerant charge	kg	72	72	93.6	93.6	124.8	124.8
N. of circuits	No.	2	2	2	2	2	2
PIPING CONNECTIONS							
Evaporator water inlet/outlet	mm	139.7	139.7	168.3	168.3	168.3	168.3

All the performances (Cooling capacity, unit power input in cooling and EER) are based on the following conditions: evaporator 12.0/7.0°C; ambient 35.0°C, unit at full load operation; operating fluid: Water ; fouling factor = 0.

(*) IW: Ivory White; GPSS: Galvanized and Painted Steel Sheet; PHE: Plate Heat Exchanger; S&T: Single Pass Shell & Tube; MCH: Microchannel; CC: Closed Cell; DPT: Direct Propeller Type; DOL: Direct On Line - VFD: Inverter - BRS: Brushless

(**) Sound power level (referred to evaporator 12/7°C, ambient 35°C full load operation) are measured in accordance with ISO 9614 and Eurovent 8/1 for Eurovent certified units. The certification refers only to the overall sound power level, the sound pressure is calculated from the sound power level and are for information only and not considered binding.

The minimum capacity indicated is referred to unit operating at standard Eurovent conditions. Dimensions and weights are for indication only and not considered binding. Before designing the installation, consult the official drawings available from the factory at request. All the data are referred to standard unit without options. Data are subject to change without notice.

EWAD~T-XLB

MODEL		EWADH10T-XL B2	EWADH11T-XL B2	EWADC13T-XL B2	EWADH13T-XL B2	EWADC14T-XL B2	EWADH15T-XL B3
COOLING PERFORMANCE							
Capacity - Cooling	kW	1.077	1.165	1.308	1.390	1.454	1.606
Capacity control - Type		Stepless	Stepless	Stepless	Stepless	Stepless	Stepless
Capacity control - Minimum capacity	%	12.5	12.5	12.5	12.5	12.5	12.5
Unit power input - Cooling	kW	347	374	421	447	481	520
EER		3.10	3.11	3.11	3.11	3.02	3.09
ESEER		3.89	3.88	3.95	3.94	3.87	3.94
IPLV		4.63	4.66	4.64	4.68	4.63	4.50
CASING							
Colour *		IW	IW	IW	IW	IW	IW
Material *		GPSS	GPSS	GPSS	GPSS	GPSS	GPSS
DIMENSIONS							
Height	mm	2537	2537	2537	2537	2537	2537
Width	mm	2282	2282	2282	2282	2282	2282
Length	mm	8676	9576	9576	10476	10476	11409
WEIGHT							
Unit Weight	kg	7798	8126	8386	8751	8765	10575
Operating Weight	kg	8259	8587	8878	9232	9235	11446
WATER HEAT EXCHANGER							
Type *		S&T	S&T	S&T	S&T	S&T	S&T
Water Volume	l	502	502	492	481	470	871
Water flow rate	l/s	51.6	55.8	62.6	66.5	69.6	76.9
Water pressure drop	kPa	51.9	60.5	36.2	40.4	50.8	45.2
Insulation material *		CC	CC	CC	CC	CC	CC
AIR HEAT EXCHANGER							
Type *		MCH	MCH	MCH	MCH	MCH	MCH
FAN							
Type *		ON-OFF (DPT)	ON-OFF (DPT)	ON-OFF (DPT)	ON-OFF (DPT)	ON-OFF (DPT)	ON-OFF (DPT)
Drive *		On/Off	On/Off	On/Off	On/Off	On/Off	On/Off
Diameter	mm	800	800	800	800	800	800
Nominal air flow	l/s	99386	110429	110429	121472	121472	132515
Quantity	No.	18	20	20	22	22	24
Speed	rpm	900	900	900	900	900	900
Motor input	kW	30.1	33.4	33.4	36.7	36.7	40.1
COMPRESSOR							
Type		Asymm Single Screw	Asymm Single Screw	Asymm Single Screw	Asymm Single Screw	Asymm Single Screw	Asymm Single Screw
Oil charge	l	42.0	42.0	50.0	50.0	50.0	75.0
Quantity	No.	2	2	2	2	2	3
SOUND LEVEL**							
Sound Power - Cooling	dB(A)	98	98	99	101	99	100
Sound Pressure level@1m distance - Cooling	dB(A)	76	76	77	77	77	77
REFRIGERANT CIRCUIT							
Refrigerant type		R134a	R134a	R134a	R134a	R134a	R134a
Refrigerant charge	kg	140.4	156	156	171.6	171.6	187
N. of circuits	No.	2	2	2	2	2	3
PIPING CONNECTIONS							
Evaporator water inlet/outlet	mm	219.1	219.1	219.1	219.1	219.1	273

All the performances (Cooling capacity, unit power input in cooling and EER) are based on the following conditions: evaporator 12.0/7.0°C; ambient 35.0°C, unit at full load operation; operating fluid: Water ; fouling factor = 0.

(*) IW: Ivory White; GPSS: Galvanized and Painted Steel Sheet; PHE: Plate Heat Exchanger; S&T: Single Pass Shell & Tube; MCH: Microchannel; CC: Closed Cell; DPT: Direct Propeller Type; DOL: Direct On Line - VFD: Inverter - BRS: Brushless

(**) Sound power level (referred to evaporator 12/7°C, ambient 35°C full load operation) are measured in accordance with ISO 9614 and Eurovent 8/1 for Eurovent certified units. The certification refers only to the overall sound power level, the sound pressure is calculated from the sound power level and are for information only and not considered binding.

The minimum capacity indicated is referred to unit operating at standard Eurovent conditions. Dimensions and weights are for indication only and not considered binding. Before designing the installation, consult the official drawings available from the factory at request. All the data are referred to standard unit without options. Data are subject to change without notice.

EWAD~T-XLB

MODEL		EWADH16T- XL B3	EWADC17T- XL B3	EWADH18T- XL B3	EWADC19T- XL B3	EWADC20T- XL B3
COOLING PERFORMANCE						
Capacity - Cooling	kW	1.705	1.836	1,952	2.027	2.088
Capacity control - Type		Stepless	Stepless	Stepless	Stepless	Stepless
Capacity control - Minimum capacity	%	12.5	12.5	12.5	12.5	12.5
Unit power input - Cooling	kW	552	589	624	662	699
EER		3.09	3.12	3.13	3.06	2.99
ESEER		3.84	3.88	3.97	3.92	3.93
IPLV		4.51	4.55	4.56	4.53	4.48
CASING						
Colour *		IW	IW	IW	IW	IW
Material *		GPSS	GPSS	GPSS	GPSS	GPSS
DIMENSIONS						
Height	mm	2537	2537	2537	2537	2537
Width	mm	2282	2282	2282	2282	2282
Length	mm	12309	13209	14109	14109	14109
WEIGHT						
Unit Weight	kg	10841	10711	10931	11451	11451
Operating Weight	kg	11712	11233	11453	12461	12461
WATER HEAT EXCHANGER						
Type *		S&T	S&T	S&T	S&T	S&T
Water Volume	l	871	522	522	1010	1010
Water flow rate	l/s	81.6	87.9	93.5	97.1	100
Water pressure drop	kPa	50.4	54.5	63.6	62.7	66.1
Insulation material *		CC	CC	CC	CC	CC
AIR HEAT EXCHANGER						
Type *		MCH	MCH	MCH	MCH	MCH
FAN						
Type *		ON-OFF (DPT)	ON-OFF (DPT)	ON-OFF (DPT)	ON-OFF (DPT)	ON-OFF (DPT)
Drive *		On/Off	On/Off	On/Off	On/Off	On/Off
Diameter	mm	800	800	800	800	800
Nominal air flow	l/s	143557	154600	165643	165643	165643
Quantity	No.	26	28	30	30	30
Speed	rpm	900	900	900	900	900
Motor input	kW	43.4	46.8	50.1	50.1	50.1
COMPRESSOR						
Type		Asymm Single Screw	Asymm Single Screw	Asymm Single Screw	Asymm Single Screw	Asymm Single Screw
Oil charge	l	75.0	75.0	75.0	75.0	75.0
Quantity	No.	3	3	3	3	3
SOUND LEVEL**						
Sound Power - Cooling	dB(A)	100	100	100	100	100
Sound Pressure level@1m distance - Cooling	dB(A)	77	77	77	77	77
REFRIGERANT CIRCUIT						
Refrigerant type		R134a	R134a	R134a	R134a	R134a
Refrigerant charge	kg	203	218	234	234	234
N. of circuits	No.	3	3	3	3	3
PIPING CONNECTIONS						
Evaporator water inlet/outlet	mm	273	273	273	273	273

All the performances (Cooling capacity, unit power input in cooling and EER) are based on the following conditions: evaporator 12.0/7.0°C; ambient 35.0°C, unit at full load operation; operating fluid: Water ; fouling factor = 0.

(* IW: Ivory White; GPSS: Galvanized and Painted Steel Sheet; PHE: Plate Heat Exchanger; S&T: Single Pass Shell & Tube; MCH: Microchannel; CC: Closed Cell; DPT: Direct Propeller Type; DOL: Direct On Line - VFD: Inverter - BRS: Brushless

(**) Sound power level (referred to evaporator 12/7°C, ambient 35°C full load operation) are measured in accordance with ISO 9614 and Eurovent 8/1 for Eurovent certified units. The certification refers only to the overall sound power level, the sound pressure is calculated from the sound power level and are for information only and not considered binding.

The minimum capacity indicated is referred to unit operating at standard Eurovent conditions. Dimensions and weights are for indication only and not considered binding. Before designing the installation, consult the official drawings available from the factory at request. All the data are referred to standard unit without options. Data are subject to change without notice.

EWAD~T-XRB

MODEL		EWAD730T- XR B2	EWAD820T- XR B2	EWAD950T- XR B2	EWADC10T- XR B2	EWADH10T- XR B2	EWADH11T- XR B2
COOLING PERFORMANCE							
Capacity - Cooling	kW	708	808	922	982	1.053	1.165
Capacity control - Type		Stepless	Stepless	Stepless	Stepless	Stepless	Stepless
Capacity control - Minimum capacity	%	12.5	12.5	12.5	12.5	12.5	12.5
Unit power input - Cooling	kW	237	272	301	338	349	374
EER		2.98	2.97	3.06	2.90	3.02	3.11
ESEER		3.94	3.87	4.07	3.85	3.91	3.88
IPLV		4.92	4.56	5.10	4.57	4.65	4.66
CASING							
Colour *		IW	IW	IW	IW	IW	IW
Material *		GPSS	GPSS	GPSS	GPSS	GPSS	GPSS
DIMENSIONS							
Height	mm	2537	2537	2537	2537	2537	2537
Width	mm	2282	2282	2282	2282	2282	2282
Length	mm	5976	5976	7776	7776	8676	9576
WEIGHT							
Unit Weight	kg	5635	5845	6441	6441	8118	8446
Operating Weight	kg	5924	6145	6771	6771	8579	8907
WATER HEAT EXCHANGER							
Type *		S&T	S&T	S&T	S&T	S&T	S&T
Water Volume	l	315	232	289	289	502	502
Water flow rate	l/s	33.8	38.6	44.1	47.0	50.4	50.4
Water pressure drop	kPa	31.6	34.9	39.2	43.9	49.8	49.8
Insulation material *		CC	CC	CC	CC	CC	CC
AIR HEAT EXCHANGER							
Type *		MCH	MCH	MCH	MCH	MCH	MCH
FAN							
Type *		ON-OFF (DPT)	ON-OFF (DPT)	ON-OFF (DPT)	ON-OFF (DPT)	ON-OFF (DPT)	ON-OFF (DPT)
Drive *		On/Off	On/Off	On/Off	On/Off	On/Off	On/Off
Diameter	mm	800	800	800	800	800	800
Nominal air flow	l/s	52172	52172	69563	69563	78258	78258
Quantity	No.	12	12	16	16	18	18
Speed	rpm	700	700	700	700	700	700
Motor input	kW	10.4	10.4	13.9	13.9	15.7	15.7
COMPRESSOR							
Type		Asymm Single Screw	Asymm Single Screw	Asymm Single Screw	Asymm Single Screw	Asymm Single Screw	Asymm Single Screw
Oil charge	l	34.0	34.0	42.0	42.0	42.0	42.0
Quantity	No.	2	2	2	2	2	2
SOUND LEVEL**							
Sound Power - Cooling	dB(A)	91	91	92	92	92	92
Sound Pressure level@1m distance - Cooling	dB(A)	70	70	70	70	70	71
REFRIGERANT CIRCUIT							
Refrigerant type		R134a	R134a	R134a	R134a	R134a	R134a
Refrigerant charge	kg	93.6	93.6	124.8	124.8	140.4	140.4
N. of circuits	No.	2	2	2	2	2	2
PIPING CONNECTIONS							
Evaporator water inlet/outlet	mm	168.3	168.3	168.3	168.3	219.1	219.1

All the performances (Cooling capacity, unit power input in cooling and EER) are based on the following conditions: evaporator 12.0/7.0°C; ambient 35.0°C, unit at full load operation; operating fluid: Water ; fouling factor = 0.

(* IW: Ivory White; GPSS: Galvanized and Painted Steel Sheet; PHE: Plate Heat Exchanger; S&T: Single Pass Shell & Tube; MCH: Microchannel; CC: Closed Cell; DPT: Direct Propeller Type; DOL: Direct On Line - VFD: Inverter - BRS: Brushless

(**) Sound power level (referred to evaporator 12/7°C, ambient 35°C full load operation) are measured in accordance with ISO 9614 and Eurovent 8/1 for Eurovent certified units. The certification refers only to the overall sound power level, the sound pressure is calculated from the sound power level and are for information only and not considered binding.

The minimum capacity indicated is referred to unit operating at standard Eurovent conditions. Dimensions and weights are for indication only and not considered binding. Before designing the installation, consult the official drawings available from the factory at request. All the data are referred to standard unit without options. Data are subject to change without notice.

EWAD~T-XRB

MODEL		EWADC13T- XR B2	EWADH13T- XR B2	EWADC14T- XR B2	EWADH15T- XR B3	EWADH16T- XR B3	EWADC17T- XR B3
COOLING PERFORMANCE							
Capacity - Cooling	kW	1.273	1.355	1.413	1.563	1.661	1.789
Capacity control - Type		Stepless	Stepless	Stepless	Stepless	Stepless	Stepless
Capacity control - Minimum capacity	%	12.5	12.5	12.5	12.5	12.5	12.5
Unit power input - Cooling	kW	426	452	490	528	559	596
EER		2.99	3.00	2.88	2.96	2.97	3.00
ESEER		3.96	3.96	3.88	3.94	3.85	3.90
IPLV		4.65	4.69	4.62	4.51	4.53	4.56
CASING							
Colour *		IW	IW	IW	IW	IW	IW
Material *		GPSS	GPSS	GPSS	GPSS	GPSS	GPSS
DIMENSIONS							
Height	mm	2537	2537	2537	2537	2537	2537
Width	mm	2282	2282	2282	2282	2282	2282
Length	mm	9576	10476	10476	11409	12309	13209
WEIGHT							
Unit Weight	kg	8706	9071	9085	11225	11491	11361
Operating Weight	kg	9198	9552	9555	12096	12362	11883
WATER HEAT EXCHANGER							
Type *		S&T	S&T	S&T	S&T	S&T	S&T
Water Volume	l	492	481	470	871	871	953
Water flow rate	l/s	60.9	64.8	67.6	74.8	79.5	85.6
Water pressure drop	kPa	34.4	38.5	48.2	43.0	48.1	52.0
Insulation material *		CC	CC	CC	CC	CC	CC
AIR HEAT EXCHANGER							
Type *		MCH	MCH	MCH	MCH	MCH	MCH
FAN							
Type *		ON-OFF (DPT)	ON-OFF (DPT)	ON-OFF (DPT)	ON-OFF (DPT)	ON-OFF (DPT)	ON-OFF (DPT)
Drive *		On/Off	On/Off	On/Off	On/Off	On/Off	On/Off
Diameter	mm	800	800	800	800	800	800
Nominal air flow	l/s	86954	95649	95649	104344	113040	121735
Quantity	No.	20	22	22	24	26	28
Speed	rpm	700	700	700	700	700	700
Motor input	kW	17.4	19.1	19.1	20.9	22.6	24.4
COMPRESSOR							
Type		Asymm Single Screw	Asymm Single Screw	Asymm Single Screw	Asymm Single Screw	Asymm Single Screw	Asymm Single Screw
Oil charge	l	50.0	50.0	50.0	75.0	75.0	75.0
Quantity	No.	2	2	2	3	3	3
SOUND LEVEL**							
Sound Power - Cooling	dB(A)	93	93	93	97	97	97
Sound Pressure level@1m distance - Cooling	dB(A)	71	71	71	75	74	74
REFRIGERANT CIRCUIT							
Refrigerant type		R134a	R134a	R134a	R134a	R134a	R134a
Refrigerant charge	kg	156	171.6	171.6	187	203	218
N. of circuits	No.	2	2	2	3	3	3
PIPING CONNECTIONS							
Evaporator water inlet/outlet	mm	219.1	219.1	219.1	273	273	273

All the performances (Cooling capacity, unit power input in cooling and EER) are based on the following conditions: evaporator 12.0/7.0°C; ambient 35.0°C, unit at full load operation; operating fluid: Water ; fouling factor = 0.

(*) IW: Ivory White; GPSS: Galvanized and Painted Steel Sheet; PHE: Plate Heat Exchanger; S&T: Single Pass Shell & Tube; MCH: Microchannel; CC: Closed Cell; DPT: Direct Propeller Type; DOL: Direct On Line - VFD: Inverter - BRS: Brushless

(**) Sound power level (referred to evaporator 12/7°C, ambient 35°C full load operation) are measured in accordance with ISO 9614 and Eurovent 8/1 for Eurovent certified units. The certification refers only to the overall sound power level, the sound pressure is calculated from the sound power level and are for information only and not considered binding.

The minimum capacity indicated is referred to unit operating at standard Eurovent conditions. Dimensions and weights are for indication only and not considered binding. Before designing the installation, consult the official drawings available from the factory at request. All the data are referred to standard unit without options. Data are subject to change without notice.

EWAD~T-XRB

MODEL		EWADH18T- XR B3	EWADC19T- XR B3	EWADC20T- XR B3
COOLING PERFORMANCE				
Capacity - Cooling	kW	1.903	1.970	2.024
Capacity control - Type		Stepless	Stepless	Stepless
Capacity control - Minimum capacity	%	12.5	12.5	12.5
Unit power input - Cooling	kW	631	674	714
EER		3.01	2.92	2.83
ESEER		3.98	3.93	3.94
IPLV		4.57	4.54	4.48
CASING				
Colour *		IW	IW	IW GPSS
Material *		GPSS	GPSS	
DIMENSIONS				
Height	mm	2537	2537	2537
Width	mm	2282	2282	2282
Length	mm	14109	14109	14109
WEIGHT				
Unit Weight	kg	11581	12101	12101
Operating Weight	kg	12103	13111	13111
WATER HEAT EXCHANGER				
Type *		S&T	S&T	S&T
Water Volume	l	935	1010	1010
Water flow rate	l/s	91.1	94.3	96.9
Water pressure drop	kPa	60.8	59.5	62.5
Insulation material *		CC	CC	CC
AIR HEAT EXCHANGER				
Type *		MCH	MCH	MCH
FAN				
Type *		ON-OFF (DPT)	ON-OFF (DPT)	ON-OFF (DPT)
Drive *		On/Off	On/Off	On/Off
Diameter	mm	800	800	800
Nominal air flow	l/s	130431	130431	130431
Quantity	No.	30	30	30
Speed	rpm	700	700	700
Motor input	kW	26.1	26.1	26.1
COMPRESSOR				
Type		Asymm Single Screw	Asymm Single Screw	Asymm Single Screw
Oil charge	l	75.0	75.0	75.0
Quantity	No.	3	3	3
SOUND LEVEL**				
Sound Power - Cooling	dB(A)	97	98	98
Sound Pressure level@1m distance - Cooling	dB(A)	74	74	74
REFRIGERANT CIRCUIT				
Refrigerant type		R134a	R134a	R134a
Refrigerant charge	kg	234	234	234
N. of circuits	No.	3	3	3
PIPING CONNECTIONS				
Evaporator water inlet/outlet	mm	273	273	273

All the performances (Cooling capacity, unit power input in cooling and EER) are based on the following conditions: evaporator 12.0/7.0°C; ambient 35.0°C, unit at full load operation; operating fluid: Water ; fouling factor = 0.

(*) IW: Ivory White; GPSS: Galvanized and Painted Steel Sheet; PHE: Plate Heat Exchanger; S&T: Single Pass Shell & Tube; MCH: Microchannel; CC: Closed Cell; DPT: Direct Propeller Type; DOL: Direct On Line - VFD: Inverter - BRS: Brushless

(**) Sound power level (referred to evaporator 12/7°C, ambient 35°C full load operation) are measured in accordance with ISO 9614 and Eurovent 8/1 for Eurovent certified units. The certification refers only to the overall sound power level, the sound pressure is calculated from the sound power level and are for information only and not considered binding.

The minimum capacity indicated is referred to unit operating at standard Eurovent conditions. Dimensions and weights are for indication only and not considered binding. Before designing the installation, consult the official drawings available from the factory at request. All the data are referred to standard unit without options. Data are subject to change without notice.

EWAD~T-SSB

MODEL		EWAD290T-SS B2	EWAD330T-SS B2	EWAD370T-SS B2	EWAD400T-SS B2	EWAD430T-SS B2	EWAD510T-SS B2
POWER SUPPLY							
Phases	No.	3	3	3	3	3	3
Frequency	Hz	50	50	50	50	50	50
Voltage	V	400	400	400	400	400	400
Voltage tolerance Minimum	%	-10%	-10%	-10%	-10%	-10%	-10%
Voltage tolerance Maximum	%	10%	10%	10%	10%	10%	10%
UNIT							
Maximum inrush current	A	253	264	306	399	417	470
Nominal running current cooling	A	76.76	94.25	195.63	109.02	123.85	144.71
Maximum running current	A	211	242	272	294	316	345
Maximum current for wires sizing	A	231	265	297	322	346	378
FANS							
Nominal running current cooling	A	15.48	15.48	20.64	20.64	20.64	20.64
COMPRESSORS							
Phases	No.	3	3	3	3	3	3
Voltage	V	400	400	400	400	400	400
Voltage tolerance Minimum	%	-10%	-10%	-10%	-10%	-10%	-10%
Voltage tolerance Maximum	%	10%	10%	10%	10%	10%	10%
Maximum running current	A	82	99	126	126	148	162
Starting method		Y-Δ	Y-Δ	Y-Δ	Y-Δ	Y-Δ	Y-Δ

MODEL		EWAD520T-SS B2	EWAD580T-SS B2	EWAD700T-SS B2	EWAD800T-SS B2	EWAD940T-SS B2	EWADC10T-SS B2
POWER SUPPLY							
Phases	No.	3	3	3	3	3	3
Frequency	Hz	50	50	50	50	50	50
Voltage	V	400	400	400	400	400	400
Voltage tolerance Minimum	%	-10%	-10%	-10%	-10%	-10%	-10%
Voltage tolerance Maximum	%	10%	10%	10%	10%	10%	10%
UNIT							
Maximum inrush current	A	493	493	574	645	697	705
Nominal running current cooling	A	148.11	171.97	370.76	422.34	486.54	534.13
Maximum running current	A	373	395	492	536	621	675
Maximum current for wires sizing	A	408	432	538	587	679	738
FANS							
Nominal running current cooling	A	25.8	25.8	30.96	30.96	36.12	36.12
COMPRESSORS							
Phases	No.	3	3	3	3	3	3
Voltage	V	400	400	400	400	400	400
Voltage tolerance Minimum	%	-10%	-10%	-10%	-10%	-10%	-10%
Voltage tolerance Maximum	%	10%	10%	10%	10%	10%	10%
Maximum running current	A	162	185	274	274	398	452
Starting method		Y-Δ	Y-Δ	Y-Δ	Y-Δ	Y-Δ	Y-Δ

Fluid: Water

Allowed voltage tolerance $\pm 10\%$. Voltage unbalance between phases must be within $\pm 3\%$.

Maximum starting current: starting current of biggest compressor + current of the other compressors at maximum load + fans current at maximum load.

In case of inverter driven units, no inrush current at start up is experienced.

Nominal current in cooling mode is referred to the following conditions: evaporator 12/7°C; ambient 35°C; compressors + fans current.

Maximum running current is based on max compressor absorbed current in its envelope and max fans absorbed current

Maximum unit current for wires sizing is based on minimum allowed voltage

Maximum current for wires sizing: (compressors full load ampere + fans current) x 1.1.

The data are referred to the standard unit without options.

For the electrical data of the hydronic kit refer to "Options technical data"

All data are subject to change without notice. Please refer to unit nameplate data.

EWAD~T-SSB

MODEL		EWADH10T-SS B2	EWADC11T-SS B2	EWADH12T-SS B2	EWADH13T-SS B2	EWADH14T-SS B2	EWADH15T-SS B3
POWER SUPPLY							
Phases	No.	3	3	3	3	3	3
Frequency	Hz	50	50	50	50	50	50
Voltage	V	400	400	400	400	400	400
Voltage tolerance Minimum	%	-10%	-10%	-10%	-10%	-10%	-10%
Voltage tolerance Maximum	%	10%	10%	10%	10%	10%	10%
UNIT							
Maximum inrush current	A	773	797	877	925	933	1075
Nominal running current cooling	A	572.46	610	692.46	727.9	763.34	839
Maximum running current	A	709	768	838	897	956	986
Maximum current for wires sizing	A	776	840	918	982	1046	1079
FANS							
Nominal running current cooling	A	36.12	41.28	41.28	46.44	51.6	56.8
COMPRESSORS							
Phases	No.	3	3	3	3	3	3
Voltage	V	400	400	400	400	400	400
Voltage tolerance Minimum	%	-10%	-10%	-10%	-10%	-10%	-10%
Voltage tolerance Maximum	%	10%	10%	10%	10%	10%	10%
Maximum running current	A	398	452	398	452	452	310
Starting method		Y-Δ	Y-Δ	Y-Δ	Y-Δ	Y-Δ	Y-Δ

MODEL		EWADH16T-SS B3	EWADC17T-SS B3	EWADH18T-SS B3	EWADC19T-SS B3	EWADC20T-SS B3	EWADC21T-SS B3
POWER SUPPLY							
Phases	No.	3	3	3	3	3	3
Frequency	Hz	50	50	50	50	50	50
Voltage	V	400	400	400	400	400	400
Voltage tolerance Minimum	%	-10%	-10%	-10%	-10%	-10%	-10%
Voltage tolerance Maximum	%	10%	10%	10%	10%	10%	10%
UNIT							
Maximum inrush current	A	1161	1217	1217	1270	1324	1324
Nominal running current cooling	A	885	951	1029	1073	1118	1158
Maximum running current	A	1118	1188	1257	1323	1389	1455
Maximum current for wires sizing	A	1223	1300	1377	1449	1521	1592
FANS							
Nominal running current cooling	A	61.9	61.9	61.9	67.08	72.24	77.4
COMPRESSORS							
Phases	No.	3	3	3	3	3	3
Voltage	V	400	400	400	400	400	400
Voltage tolerance Minimum	%	-10%	-10%	-10%	-10%	-10%	-10%
Voltage tolerance Maximum	%	10%	10%	10%	10%	10%	10%
Maximum running current	A	398	398	398	459	459	459
Starting method		Y-Δ	Y-Δ	Y-Δ	Y-Δ	Y-Δ	Y-Δ

Fluid: Water

Allowed voltage tolerance $\pm 10\%$. Voltage unbalance between phases must be within $\pm 3\%$.

Maximum starting current: starting current of biggest compressor + current of the other compressors at maximum load + fans current at maximum load.

In case of inverter driven units, no inrush current at start up is experienced.

Nominal current in cooling mode is referred to the following conditions: evaporator 12/7°C; ambient 35°C; compressors + fans current.

Maximum running current is based on max compressor absorbed current in its envelope and max fans absorbed current

Maximum unit current for wires sizing is based on minimum allowed voltage

Maximum current for wires sizing: (compressors full load ampere + fans current) x 1,1.

The data are referred to the standard unit without options.

For the electrical data of the hydronic kit refer to "Options technical data"

All data are subject to change without notice. Please refer to unit nameplate data.

EWAD~T-SLB

MODEL		EWAD290T-SL B2	EWAD330T-SL B2	EWAD370T-SL B2	EWAD400T-SL B2	EWAD430T-SL B2	EWAD510T-SL B2
POWER SUPPLY							
Phases	No.	3	3	3	3	3	3
Frequency	Hz	50	50	50	50	50	50
Voltage	V	400	400	400	400	400	400
Voltage tolerance Minimum	%	-10%	-10%	-10%	-10%	-10%	-10%
Voltage tolerance Maximum	%	10%	10%	10%	10%	10%	10%
UNIT							
Maximum inrush current	A	253	264	306	399	417	470
Nominal running current cooling	A	76.76	94.25	195.63	109.02	123.85	144.71
Maximum running current	A	211	242	272	294	316	345
Maximum current for wires sizing	A	231	265	297	322	346	378
FANS							
Nominal running current cooling	A	15.48	15.48	20.64	20.64	20.64	20.64
COMPRESSORS							
Phases	No.	3	3	3	3	3	3
Voltage	V	400	400	400	400	400	400
Voltage tolerance Minimum	%	-10%	-10%	-10%	-10%	-10%	-10%
Voltage tolerance Maximum	%	10%	10%	10%	10%	10%	10%
Maximum running current	A	82	99	126	126	148	162
Starting method		Y-Δ	Y-Δ	Y-Δ	Y-Δ	Y-Δ	Y-Δ

MODEL		EWAD520T-SL B2	EWAD580T-SL B2	EWAD700T-SL B2	EWAD800T-SL B2	EWAD940T-SL B2	EWADC10T-SL B2
POWER SUPPLY							
Phases	No.	3	3	3	3	3	3
Frequency	Hz	50	50	50	50	50	50
Voltage	V	400	400	400	400	400	400
Voltage tolerance Minimum	%	-10%	-10%	-10%	-10%	-10%	-10%
Voltage tolerance Maximum	%	10%	10%	10%	10%	10%	10%
UNIT							
Maximum inrush current	A	493	493	574	645	697	705
Nominal running current cooling	A	148.11	171.97	370.76	422.34	486.54	534.13
Maximum running current	A	373	395	492	536	621	675
Maximum current for wires sizing	A	408	432	538	587	679	738
FANS							
Nominal running current cooling	A	25.8	25.8	30.96	30.96	36.12	36.12
COMPRESSORS							
Phases	No.	3	3	3	3	3	3
Voltage	V	400	400	400	400	400	400
Voltage tolerance Minimum	%	-10%	-10%	-10%	-10%	-10%	-10%
Voltage tolerance Maximum	%	10%	10%	10%	10%	10%	10%
Maximum running current	A	162	185	274	274	398	452
Starting method		Y-Δ	Y-Δ	Y-Δ	Y-Δ	Y-Δ	Y-Δ

Fluid: Water

Allowed voltage tolerance $\pm 10\%$. Voltage unbalance between phases must be within $\pm 3\%$.

Maximum starting current: starting current of biggest compressor + current of the other compressors at maximum load + fans current at maximum load.

In case of inverter driven units, no inrush current at start up is experienced.

Nominal current in cooling mode is referred to the following conditions: evaporator 12/7°C; ambient 35°C; compressors + fans current.

Maximum running current is based on max compressor absorbed current in its envelope and max fans absorbed current

Maximum unit current for wires sizing is based on minimum allowed voltage

Maximum current for wires sizing: (compressors full load ampere + fans current) x 1.1.

The data are referred to the standard unit without options.

For the electrical data of the hydronic kit refer to "Options technical data"

All data are subject to change without notice. Please refer to unit nameplate data.

EWAD~T-SLB

MODEL		EWADH10T-SL B2	EWADC11T-SL B2	EWADH12T-SL B2	EWADH13T-SL B2	EWADH14T-SL B2	EWADH15T-SL B2
POWER SUPPLY							
Phases	No.	3	3	3	3	3	3
Frequency	Hz	50	50	50	50	50	50
Voltage	V	400	400	400	400	400	400
Voltage tolerance Minimum	%	-10%	-10%	-10%	-10%	-10%	-10%
Voltage tolerance Maximum	%	10%	10%	10%	10%	10%	10%
UNIT							
Maximum inrush current	A	773	797	877	925	933	1075
Nominal running current cooling	A	572.46	610	692.46	727.9	763.34	839
Maximum running current	A	709	768	838	897	956	986
Maximum current for wires sizing	A	776	840	918	982	1046	1079
FANS							
Nominal running current cooling	A	36.12	41.28	41.28	46.44	51.6	56.8
COMPRESSORS							
Phases	No.	3	3	3	3	3	3
Voltage	V	400	400	400	400	400	400
Voltage tolerance Minimum	%	-10%	-10%	-10%	-10%	-10%	-10%
Voltage tolerance Maximum	%	10%	10%	10%	10%	10%	10%
Maximum running current	A	398	452	398	452	452	310
Starting method		Y-Δ	Y-Δ	Y-Δ	Y-Δ	Y-Δ	Y-Δ

MODEL		EWADH16T-SL B3	EWADC17T-SL B3	EWADH18T-SL B3	EWADC19T-SL B3	EWADC20T-SL B3	EWADC21T-SL B3
POWER SUPPLY							
Phases	No.	3	3	3	3	3	3
Frequency	Hz	50	50	50	50	50	50
Voltage	V	400	400	400	400	400	400
Voltage tolerance Minimum	%	-10%	-10%	-10%	-10%	-10%	-10%
Voltage tolerance Maximum	%	10%	10%	10%	10%	10%	10%
UNIT							
Maximum inrush current	A	1161	1217	1217	1270	1324	1324
Nominal running current cooling	A	885	951	1029	1073	1118	1158
Maximum running current	A	1118	1188	1257	1323	1389	1455
Maximum current for wires sizing	A	1223	1300	1377	1449	1521	1592
FANS							
Nominal running current cooling	A	61.9	61.9	61.9	67.08	72.24	77.4
COMPRESSORS							
Phases	No.	3	3	3	3	3	3
Voltage	V	400	400	400	400	400	400
Voltage tolerance Minimum	%	-10%	-10%	-10%	-10%	-10%	-10%
Voltage tolerance Maximum	%	10%	10%	10%	10%	10%	10%
Maximum running current	A	398	398	398	459	459	459
Starting method		Y-Δ	Y-Δ	Y-Δ	Y-Δ	Y-Δ	Y-Δ

Fluid: Water

Allowed voltage tolerance $\pm 10\%$. Voltage unbalance between phases must be within $\pm 3\%$.

Maximum starting current: starting current of biggest compressor + current of the other compressors at maximum load + fans current at maximum load.

In case of inverter driven units, no inrush current at start up is experienced.

Nominal current in cooling mode is referred to the following conditions: evaporator 12/7°C; ambient 35°C; compressors + fans current.

Maximum running current is based on max compressor absorbed current in its envelope and max fans absorbed current

Maximum unit current for wires sizing is based on minimum allowed voltage

Maximum current for wires sizing: (compressors full load ampere + fans current) x 1,1.

The data are referred to the standard unit without options.

For the electrical data of the hydronic kit refer to "Options technical data"

All data are subject to change without notice. Please refer to unit nameplate data.

EWAD~T-SLB

MODEL		EWAD700T-SR B2	EWAD800T-SR B2	EWAD940T-SR B2	EWADC10T-SR B2	EWADH10T-SR B2	EWADC11T-SR B2
POWER SUPPLY							
Phases	No.	3	3	3	3	3	3
Frequency	Hz	50	50	50	50	50	50
Voltage	V	400	400	400	400	400	400
Voltage tolerance Minimum	%	-10%	-10%	-10%	-10%	-10%	-10%
Voltage tolerance Maximum	%	10%	10%	10%	10%	10%	10%
UNIT							
Maximum inrush current	A	567	638	693	701	766	786
Nominal running current cooling	A	376.73	431.76	499.71	554.32	592.7	629.99
Maximum running current	A	478	523	605	659	693	750
Maximum current for wires sizing	A	524	573	663	722	760	822
FANS							
Nominal running current cooling	A	17.28	17.28	20.16	20.16	20.16	23.04
COMPRESSORS							
Phases	No.	3	3	3	3	3	3
Voltage	V	400	400	400	400	400	400
Voltage tolerance Minimum	%	-10%	-10%	-10%	-10%	-10%	-10%
Voltage tolerance Maximum	%	10%	10%	10%	10%	10%	10%
Maximum running current	A	274	274	398	452	398	452
Starting method		Y-Δ	Y-Δ	Y-Δ	Y-Δ	Y-Δ	Y-Δ

MODEL		EWADH12T-SR B2	EWADH13T-SR B2	EWADH14T-SR B2	EWADH15T-SR B3	EWADH16T-SR B3	EWADC17T-SR B3
POWER SUPPLY							
Phases	No.	3	3	3	3	3	3
Frequency	Hz	50	50	50	50	50	50
Voltage	V	400	400	400	400	400	400
Voltage tolerance Minimum	%	-10%	-10%	-10%	-10%	-10%	-10%
Voltage tolerance Maximum	%	10%	10%	10%	10%	10%	10%
UNIT							
Maximum inrush current	A	868	914	922	1057	1143	1199
Nominal running current cooling	A	720.93	755.84	790.74	864	909	984
Maximum running current	A	820	876	933	961	1091	1160
Maximum current for wires sizing	A	900	962	1023	1054	1196	1273
FANS							
Nominal running current cooling	A	23.04	25.92	28.8	31.7	34.6	34.6
COMPRESSORS							
Phases	No.	3	3	3	3	3	3
Voltage	V	400	400	400	400	400	400
Voltage tolerance Minimum	%	-10%	-10%	-10%	-10%	-10%	-10%
Voltage tolerance Maximum	%	10%	10%	10%	-10%	10%	10%
Maximum running current	A	398	452	452	310	398	398
Starting method		Y-Δ	Y-Δ	Y-Δ	Y-Δ	Y-Δ	Y-Δ

Fluid: Water

Allowed voltage tolerance $\pm 10\%$. Voltage unbalance between phases must be within $\pm 3\%$.

Maximum starting current: starting current of biggest compressor + current of the other compressors at maximum load + fans current at maximum load.

In case of inverter driven units, no inrush current at start up is experienced.

Nominal current in cooling mode is referred to the following conditions: evaporator 12/7°C; ambient 35°C; compressors + fans current.

Maximum running current is based on max compressor absorbed current in its envelope and max fans absorbed current

Maximum unit current for wires sizing is based on minimum allowed voltage

Maximum current for wires sizing: (compressors full load ampere + fans current) x 1.1.

The data are referred to the standard unit without options.

For the electrical data of the hydronic kit refer to "Options technical data"

All data are subject to change without notice. Please refer to unit nameplate data.

EWAD~T-SRB

MODEL		EWADH18T - SR B3	EWADC19T - SR B3	EWADC20T - SR B2	EWADC21T- SR B2
POWER SUPPLY					
Phases	No.	3	3	3	3
Frequency	Hz	50	50	50	50
Voltage	V	400	400	400	400
Voltage tolerance Minimum	%	-10%	-10%	-10%	-10%
Voltage tolerance Maximum	%	10%	10%	10%	10%
UNIT					
Maximum inrush current	A	1199	1250	1301	1301
Nominal running current cooling	A	1070	1115	1161	1201
Maximum running current	A	1230	1293	1357	1420
Maximum current for wires sizing	A	1349	1419	1489	1558
FANS					
Nominal running current cooling	A	34.6	37.4	40.3	43.2
COMPRESSORS					
Phases	No.	3	3	3	3
Voltage	V	400	400	400	400
Voltage tolerance Minimum	%	-10%	-10%	-10%	-10%
Voltage tolerance Maximum	%	10%	10%	10%	10%
Maximum running current	A	398	459	459	459
Starting method		Y-Δ	Y-Δ	Y-Δ	Y-Δ

Fluid: Water

Allowed voltage tolerance $\pm 10\%$. Voltage unbalance between phases must be within $\pm 3\%$.

Maximum starting current: starting current of biggest compressor + current of the other compressors at maximum load + fans current at maximum load.
In case of inverter driven units, no inrush current at start up is experienced.

Nominal current in cooling mode is referred to the following conditions: evaporator 12/7°C; ambient 35°C; compressors + fans current.

Maximum running current is based on max compressor absorbed current in its envelope and max fans absorbed current

Maximum unit current for wires sizing is based on minimum allowed voltage

Maximum current for wires sizing: (compressors full load ampere + fans current) x 1,1.

The data are referred to the standard unit without options.

For the electrical data of the hydronic kit refer to "Options technical data"

All data are subject to change without notice. Please refer to unit nameplate data.

EWAD~T-XSB

MODEL		EWAD350T- XS B2	EWAD380T- XS B2	EWAD400T- XS B2	EWAD420T- XS B2	EWAD440T- XS B2	EWAD490T- XS B2
POWER SUPPLY							
Phases	No.	3	3	3	3	3	3
Frequency	Hz	50	50	50	50	50	50
Voltage	V	400	400	400	400	400	400
Voltage tolerance Minimum	%	-10%	-10%	-10%	-10%	-10%	-10%
Voltage tolerance Maximum	%	10%	10%	10%	10%	10%	10%
UNIT							
Maximum inrush current	A	253	296	311	399	422	475
Nominal running current cooling	A	174.38	97.83	114.97	114.79	129.16	147.79
Maximum running current	A	248	260	277	299	322	351
Maximum current for wires sizing	A	270	284	302	327	351	383
FANS							
Nominal running current cooling	A	20.64	20.64	25.8	25.8	25.8	25.8
COMPRESSORS							
Phases	No.	3	3	3	3	3	3
Voltage	V	400	400	400	400	400	400
Voltage tolerance Minimum	%	-10%	-10%	-10%	-10%	-10%	-10%
Voltage tolerance Maximum	%	10%	10%	10%	10%	10%	10%
Maximum running current	A	114	114	126	126	148	162
Starting method		Y-Δ	Y-Δ	Y-Δ	Y-Δ	Y-Δ	Y-Δ

MODEL		EWAD540T- XS B2	EWAD570T- XS B2	EWAD730T- XS B2	EWAD820T- XS B2	EWAD950T- XS B2	EWADC10T- XS B2
POWER SUPPLY							
Phases	No.	3	3	3	3	3	3
Frequency	Hz	50	50	50	50	50	50
Voltage	V	400	400	400	400	400	400
Voltage tolerance Minimum	%	-10%	-10%	-10%	-10%	-10%	-10%
Voltage tolerance Maximum	%	10%	10%	10%	10%	10%	10%
UNIT							
Maximum inrush current	A	493	493	574	645	703	705
Nominal running current cooling	A	141.98	158.14	372.87	424.09	471.71	521
Maximum running current	A	378	401	492	536	626	680
Maximum current for wires sizing	A	413	438	538	587	685	744
FANS							
Nominal running current cooling	A	30.96	30.96	30.96	30.96	41.28	41.28
COMPRESSORS							
Phases	No.	3	3	3	3	3	3
Voltage	V	400	400	400	400	400	400
Voltage tolerance Minimum	%	-10%	-10%	-10%	-10%	-10%	-10%
Voltage tolerance Maximum	%	10%	10%	10%	10%	10%	10%
Maximum running current	A	162	185	274	274	398	452
Starting method		Y-Δ	Y-Δ	Y-Δ	Y-Δ	Y-Δ	Y-Δ

Fluid: Water

Allowed voltage tolerance $\pm 10\%$. Voltage unbalance between phases must be within $\pm 3\%$.

Maximum starting current: starting current of biggest compressor + current of the other compressors at maximum load + fans current at maximum load.

In case of inverter driven units, no inrush current at start up is experienced.

Nominal current in cooling mode is referred to the following conditions: evaporator 12/7°C; ambient 35°C; compressors + fans current.

Maximum running current is based on max compressor absorbed current in its envelope and max fans absorbed current

Maximum unit current for wires sizing is based on minimum allowed voltage

Maximum current for wires sizing: (compressors full load ampere + fans current) x 1.1.

The data are referred to the standard unit without options.

For the electrical data of the hydronic kit refer to "Options technical data"

All data are subject to change without notice. Please refer to unit nameplate data.

EWAD~T-XSB

MODEL		EWADH10T- XS B2	EWADH11T- XS B2	EWADC13T- XS B2	EWADH13T- XS B2	EWADC14T- XS B2	EWADH15T- XS B3
POWER SUPPLY							
Phases	No.	3	3	3	3	3	3
Frequency	Hz	50	50	50	50	50	50
Voltage	V	400	400	400	400	400	400
Voltage tolerance Minimum	%	-10%	-10%	-10%	-10%	-10%	-10%
Voltage tolerance Maximum	%	10%	10%	10%	10%	10%	-10%
UNIT							
Maximum inrush current	A	778	802	883	931	939	1075
Nominal running current cooling	A	546.1	584.5	662.5	699.2	749.6	818
Maximum running current	A	719	778	848	907	961	991
Maximum current for wires sizing	A	787	851	928	992	1051	1084
FANS							
Nominal running current cooling	A	46.44	51.6	51.6	56.8	56.76	61.9
COMPRESSORS							
Phases	No.	3	3	3	3	3	3
Voltage	V	400	400	400	400	400	400
Voltage tolerance Minimum	%	-10%	-10%	-10%	-10%	-10%	-10%
Voltage tolerance Maximum	%	10%	10%	10%	10%	10%	-10%
Maximum running current	A	398	452	398	452	452	310
Starting method		Y-Δ	Y-Δ	Y-Δ	Y-Δ	Y-Δ	Y-Δ

MODEL		EWADH16T- - XS B3	EWADC17T- - XS B3	EWADH18T- - XS B3	EWADC19T- - XS B3	EWADC20T- - XS B3
POWER SUPPLY						
Phases	No.	3	3	3	3	3
Frequency	Hz	50	50	50	50	50
Voltage	V	400	400	400	400	400
Voltage tolerance Minimum	%	-10%	-10%	-10%	-10%	-10%
Voltage tolerance Maximum	%	10%	10%	10%	10%	10%
UNIT						
Maximum inrush current	A	1166	1227	1227	1276	1324
Nominal running current cooling	A	867	924	978	1040	1099
Maximum running current	A	1123	1198	1273	1333	1394
Maximum current for wires sizing	A	1229	1310	1392	1459	1526
FANS						
Nominal running current cooling	A	67.1	72.2	77.4	77.4	77.4
COMPRESSORS						
Phases	No.	3	3	3	3	3
Voltage	V	400	400	400	400	400
Voltage tolerance Minimum	%	-10%	-10%	-10%	-10%	-10%
Voltage tolerance Maximum	%	10%	10%	10%	10%	10%
Maximum running current	A	398	398	398	459	459
Starting method		Y-Δ	Y-Δ	Y-Δ	Y-Δ	Y-Δ

Fluid: Water

Allowed voltage tolerance $\pm 10\%$. Voltage unbalance between phases must be within $\pm 3\%$.

Maximum starting current: starting current of biggest compressor + current of the other compressors at maximum load + fans current at maximum load.

In case of inverter driven units, no inrush current at start up is experienced.

Nominal current in cooling mode is referred to the following conditions: evaporator 12/7°C; ambient 35°C; compressors + fans current.

Maximum running current is based on max compressor absorbed current in its envelope and max fans absorbed current

Maximum unit current for wires sizing is based on minimum allowed voltage

Maximum current for wires sizing: (compressors full load ampere + fans current) x 1,1.

The data are referred to the standard unit without options.

For the electrical data of the hydronic kit refer to "Options technical data"

All data are subject to change without notice. Please refer to unit nameplate data.

EWAD~T-XLB

MODEL		EWAD350T-XL B2	EWAD380T-XL B2	EWAD400T-XL B2	EWAD420T-XL B2	EWAD440T-XL B2	EWAD490T-XL B2
POWER SUPPLY							
Phases	No.	3	3	3	3	3	3
Frequency	Hz	50	50	50	50	50	50
Voltage	V	400	400	400	400	400	400
Voltage tolerance Minimum	%	-10%	-10%	-10%	-10%	-10%	-10%
Voltage tolerance Maximum	%	10%	10%	10%	10%	10%	10%
UNIT							
Maximum inrush current	A	253	296	311	399	422	475
Nominal running current cooling	A	174.38	97.83	114.97	114.79	129.16	147.79
Maximum running current	A	248	260	277	299	322	351
Maximum current for wires sizing	A	270	284	302	327	351	383
FANS							
Nominal running current cooling	A	20.64	20.64	25.8	25.8	25.8	25.8
COMPRESSORS							
Phases	No.	3	3	3	3	3	3
Voltage	V	400	400	400	400	400	400
Voltage tolerance Minimum	%	-10%	-10%	-10%	-10%	-10%	-10%
Voltage tolerance Maximum	%	10%	10%	10%	10%	10%	10%
Maximum running current	A	114	114	126	126	148	162
Starting method		Y-Δ	Y-Δ	Y-Δ	Y-Δ	Y-Δ	Y-Δ

MODEL		EWAD540T-XL B2	EWAD570T-XL B2	EWAD730T-XL B2	EWAD820T-XL B2	EWAD950T-XL B2	EWADC10T-XL B2
POWER SUPPLY							
Phases	No.	3	3	3	3	3	3
Frequency	Hz	50	50	50	50	50	50
Voltage	V	400	400	400	400	400	400
Voltage tolerance Minimum	%	-10%	-10%	-10%	-10%	-10%	-10%
Voltage tolerance Maximum	%	10%	10%	10%	10%	10%	10%
UNIT							
Maximum inrush current	A	493	493	574	645	703	705
Nominal running current cooling	A	141.98	158.14	372.87	424.09	471.71	521
Maximum running current	A	378	401	492	536	626	680
Maximum current for wires sizing	A	413	438	538	587	685	744
FANS							
Nominal running current cooling	A	30.96	30.96	30.96	30.96	41.28	41.28
COMPRESSORS							
Phases	No.	3	3	3	3	3	3
Voltage	V	400	400	400	400	400	400
Voltage tolerance Minimum	%	-10%	-10%	-10%	-10%	-10%	-10%
Voltage tolerance Maximum	%	10%	10%	10%	10%	10%	10%
Maximum running current	A	162	185	274	274	398	452
Starting method		Y-Δ	Y-Δ	Y-Δ	Y-Δ	Y-Δ	Y-Δ

Fluid: Water

Allowed voltage tolerance $\pm 10\%$. Voltage unbalance between phases must be within $\pm 3\%$.

Maximum starting current: starting current of biggest compressor + current of the other compressors at maximum load + fans current at maximum load.

In case of inverter driven units, no inrush current at start up is experienced.

Nominal current in cooling mode is referred to the following conditions: evaporator 12/7°C; ambient 35°C; compressors + fans current.

Maximum running current is based on max compressor absorbed current in its envelope and max fans absorbed current

Maximum unit current for wires sizing is based on minimum allowed voltage

Maximum current for wires sizing: (compressors full load ampere + fans current) x 1.1.

The data are referred to the standard unit without options.

For the electrical data of the hydronic kit refer to "Options technical data"

All data are subject to change without notice. Please refer to unit nameplate data.

EWAD~T-XLB

MODEL		EWADH10T- XL B2	EWADH11T- XL B2	EWADC13T- XL B2	EWADH13T- XL B2	EWADC14T- XL B2	EWADH15T- XL B3
POWER SUPPLY							
Phases	No.	3	3	3	3	3	3
Frequency	Hz	50	50	50	50	50	50
Voltage	V	400	400	400	400	400	400
Voltage tolerance Minimum	%	-10%	-10%	-10%	-10%	-10%	-10%
Voltage tolerance Maximum	%	10%	10%	10%	10%	10%	10%
UNIT							
Maximum inrush current	A	778	802	883	931	939	1075
Nominal running current cooling	A	546.1	584.5	662.5	699.17	749.6	818
Maximum running current	A	719	778	848	907	961	991
Maximum current for wires sizing	A	787	851	928	992	1051	1084
FANS							
Nominal running current cooling	A	46.4	51.6	51.6	56.76	56.76	61.9
COMPRESSORS							
Phases	No.	3	3	3	3	3	3
Voltage	V	400	400	400	400	400	400
Voltage tolerance Minimum	%	-10%	-10%	-10%	-10%	-10%	-10%
Voltage tolerance Maximum	%	10%	10%	10%	10%	10%	10%
Maximum running current	A	398	452	398	452	452	310
Starting method		Y-Δ	Y-Δ	Y-Δ	Y-Δ	Y-Δ	Y-Δ

MODEL		EWADH16T- - XL B3	EWADC17T- - XL B3	EWADH18T- - XL B3	EWADC19T- - XL B3	EWADC20T- - XL B3
POWER SUPPLY						
Phases	No.	3	3	3	3	3
Frequency	Hz	50	50	50	50	50
Voltage	V	400	400	400	400	400
Voltage tolerance Minimum	%	-10%	-10%	-10%	-10%	-10%
Voltage tolerance Maximum	%	10%	10%	10%	10%	10%
UNIT						
Maximum inrush current	A	1166	1227	1227	1276	1324
Nominal running current cooling	A	867	924	978	1040	1099
Maximum running current	A	1123	1198	1273	1333	1394
Maximum current for wires sizing	A	1229	1310	1392	1459	1526
FANS						
Nominal running current cooling	A	67.1	72.2	77.4	77.4	77.4
COMPRESSORS						
Phases	No.	3	3	3	3	3
Voltage	V	400	400	400	400	400
Voltage tolerance Minimum	%	-10%	-10%	-10%	-10%	-10%
Voltage tolerance Maximum	%	10%	10%	10%	10%	10%
Maximum running current	A	398	398	398	459	459
Starting method		Y-Δ	Y-Δ	Y-Δ	Y-Δ	Y-Δ

Fluid: Water

Allowed voltage tolerance $\pm 10\%$. Voltage unbalance between phases must be within $\pm 3\%$.

Maximum starting current: starting current of biggest compressor + current of the other compressors at maximum load + fans current at maximum load.

In case of inverter driven units, no inrush current at start up is experienced.

Nominal current in cooling mode is referred to the following conditions: evaporator 12/7°C; ambient 35°C; compressors + fans current.

Maximum running current is based on max compressor absorbed current in its envelope and max fans absorbed current

Maximum unit current for wires sizing is based on minimum allowed voltage

Maximum current for wires sizing: (compressors full load ampere + fans current) x 1,1.

The data are referred to the standard unit without options.

For the electrical data of the hydronic kit refer to "Options technical data"

All data are subject to change without notice. Please refer to unit nameplate data.

EWAD~T-XLB

MODEL		EWAD730T- XR B2	EWAD820T- XR B2	EWAD950T- XR B2	EWADC10T- XR B2	EWADH10T- XR B2	EWADH11T- XR B2
POWER SUPPLY							
Phases	No.	3	3	3	3	3	3
Frequency	Hz	50	50	50	50	50	50
Voltage	V	400	400	400	400	400	400
Voltage tolerance Minimum	%	-10%	-10%	-10%	-10%	-10%	-10%
Voltage tolerance Maximum	%	10%	10%	10%	10%	10%	10%
UNIT							
Maximum inrush current	A	567	638	696	701	769	802
Nominal running current cooling	A	379.04	433.58	477.39	533.75	552.3	584.5
Maximum running current	A	478	523	608	662	699	778
Maximum current for wires sizing	A	524	573	666	725	766	851
FANS							
Nominal running current cooling	A	17.28	17.28	23.04	23.04	25.9	51.6
COMPRESSORS							
Phases	No.	3	3	3	3	3	3
Voltage	V	400	400	400	400	400	400
Voltage tolerance Minimum	%	-10%	-10%	-10%	-10%	-10%	-10%
Voltage tolerance Maximum	%	10%	10%	10%	10%	10%	10%
Maximum running current	A	274	274	398	452	398	452
Starting method		Y-Δ	Y-Δ	Y-Δ	Y-Δ	Y-Δ	Y-Δ

MODEL		EWADC13T- XR B2	EWADH13T- XR B2	EWADC14T- XR B2	EWADH15T- XR B3	EWADH16T- XR B3	EWADC17T- XR B3
POWER SUPPLY							
Phases	No.	3	3	3	3	3	3
Frequency	Hz	50	50	50	50	50	50
Voltage	V	400	400	400	400	400	400
Voltage tolerance Minimum	%	-10%	-10%	-10%	-10%	-10%	-10%
Voltage tolerance Maximum	%	10%	10%	10%	10%	10%	10%
UNIT							
Maximum inrush current	A	871	917	925	1057	1146	1204
Nominal running current cooling	A	675.01	711.6	769.5	834	883	941
Maximum running current	A	826	882	936	964	1093	1166
Maximum current for wires sizing	A	905	967	1026	1057	1199	1279
FANS							
Nominal running current cooling	A	28.8	31.7	31.68	34.6	37.4	40.3
COMPRESSORS							
Phases	No.	3	3	3	3	3	3
Voltage	V	400	400	400	400	400	400
Voltage tolerance Minimum	%	-10%	-10%	-10%	-10%	-10%	-10%
Voltage tolerance Maximum	%	10%	10%	10%	10%	10%	10%
Maximum running current	A	398	452	452	310	398	398
Starting method		Y-Δ	Y-Δ	Y-Δ	Y-Δ	Y-Δ	Y-Δ

Fluid: Water

Allowed voltage tolerance $\pm 10\%$. Voltage unbalance between phases must be within $\pm 3\%$.

Maximum starting current: starting current of biggest compressor + current of the other compressors at maximum load + fans current at maximum load.

In case of inverter driven units, no inrush current at start up is experienced.

Nominal current in cooling mode is referred to the following conditions: evaporator 12/7°C; ambient 35°C; compressors + fans current.

Maximum running current is based on max compressor absorbed current in its envelope and max fans absorbed current

Maximum unit current for wires sizing is based on minimum allowed voltage

Maximum current for wires sizing: (compressors full load ampere + fans current) x 1.1.

The data are referred to the standard unit without options.

For the electrical data of the hydronic kit refer to "Options technical data"

All data are subject to change without notice. Please refer to unit nameplate data.

EWAD~T-XRB

MODEL		EWADH18T- XR B3	EWADC19T- XR B3	EWADC20T- XR B3
POWER SUPPLY				
Phases	No.	3	3	3
Frequency	Hz	50	50	50
Voltage	V	400	400	400
Voltage tolerance Minimum	%	-10%	-10%	-10%
Voltage tolerance Maximum	%	10%	10%	10%
UNIT				
Maximum inrush current	A	1204	1253	1301
Nominal running current cooling	A	995	1067	1134
Maximum running current	A	1239	1299	1360
Maximum current for wires sizing	A	1358	1425	1491
FANS				
Nominal running current cooling	A	43.2	43.2	43.2
COMPRESSORS				
Phases	No.	3	3	3
Voltage	V	400	400	400
Voltage tolerance Minimum	%	-10%	-10%	-10%
Voltage tolerance Maximum	%	10%	10%	10%
Maximum running current	A	398	459	459
Starting method		Y-Δ	Y-Δ	Y-Δ

Fluid: Water

Allowed voltage tolerance $\pm 10\%$. Voltage unbalance between phases must be within $\pm 3\%$.

Maximum starting current: starting current of biggest compressor + current of the other compressors at maximum load + fans current at maximum load.
In case of inverter driven units, no inrush current at start up is experienced.

Nominal current in cooling mode is referred to the following conditions: evaporator 12/7°C; ambient 35°C; compressors + fans current.

Maximum running current is based on max compressor absorbed current in its envelope and max fans absorbed current

Maximum unit current for wires sizing is based on minimum allowed voltage

Maximum current for wires sizing: (compressors full load ampere + fans current) x 1,1.

The data are referred to the standard unit without options.

For the electrical data of the hydronic kit refer to "Options technical data"

All data are subject to change without notice. Please refer to unit nameplate data.

EWAD~T-SSB

MODEL	Sound pressure level at 1 m from the unit (rif. 2 x 10 ⁻⁵ Pa)									Power db(A)
	63 Hz	125 Hz	250 Hz	500 Hz	1000 Hz	2000 Hz	4000 Hz	8000 Hz	db(A)	
290	78.0	75.0	75.0	78.0	73.0	68.0	60.0	53.0	78	98
330	78.0	75.0	75.0	78.0	73.0	68.0	60.0	53.0	78	98
370	78.0	75.0	75.0	78.0	73.0	68.0	60.0	53.0	78	98
400	78.0	75.0	75.0	78.0	73.0	68.0	60.0	53.0	78	98
430	78.0	75.0	75.0	78.0	73.0	68.0	60.0	53.0	78	98
510	81.0	78.0	78.0	81.0	76.0	71.0	63.0	56.0	81	101
520	81.0	78.0	78.0	81.0	76.0	71.0	63.0	56.0	81	101
580	81.0	78.0	78.0	81.0	76.0	71.0	63.0	56.0	81	101
700	78.0	75.0	75.0	78.0	73.0	68.0	60.0	53.0	78	99
800	79.0	76.0	76.0	78.0	73.0	69.0	61.0	53.0	78	99
940	79.0	76.0	76.0	78.0	73.0	69.0	61.0	53.0	78	99
C10	79.0	76.0	76.0	79.0	73.0	69.0	61.0	54.0	79	100
H10	79.0	76.0	76.0	78.0	73.0	69.0	61.0	53.0	79	100
C11	78.0	75.0	75.0	78.0	73.0	68.0	60.0	53.0	78	100
H12	78.0	75.0	75.0	78.0	73.0	68.0	60.0	53.0	78	100
H13	79.0	76.0	76.0	79.0	74.0	69.0	61.0	54.0	79	101
H14	79.0	76.0	76.0	79.0	74.0	69.0	61.0	54.0	79	101
H15	75.0	77.0	80.0	79.0	75.0	71.0	61.0	52.0	80	103
H16	75.0	77.0	80.0	79.0	75.0	70.0	61.0	52.0	80	103
C17	75.0	77.0	80.0	79.0	75.0	70.0	61.0	52.0	80	103
H18	75.0	77.0	80.0	79.0	75.0	70.0	61.0	52.0	80	103
C19	75.0	77.0	80.0	79.0	75.0	70.0	61.0	52.0	80	103
C20	75.0	77.0	80.0	79.0	75.0	71.0	61.0	52.0	80	103
C21	75.0	77.0	80.0	79.0	75.0	71.0	61.0	52.0	80	103

Sound power level (referred to evaporator 12/7°C, ambient 35°C full load operation) are measured in accordance with ISO 9614 and Eurovent 8/1 for Eurovent certified units. The certification refers only to the overall sound power level.
The sound data in the Octave band spectrum is for intended for reference only and not considering binding.
The sound pressure is calculated from the sound power level and are for information only and not considered binding.
The data are referred to the standard unit without options.

EWAD~T-SLB

MODEL	Sound pressure level at 1 m from the unit (rif. 2 x 10 ⁻⁵ Pa)									Power db(A)
	63 Hz	125 Hz	250 Hz	500 Hz	1000 Hz	2000 Hz	4000 Hz	8000 Hz	db(A)	
290	75.0	72.0	72.0	74.0	69.0	65.0	57.0	49.0	74	94
330	75.0	72.0	72.0	74.0	69.0	65.0	57.0	49.0	74	94
370	75.0	72.0	72.0	75.0	70.0	65.0	57.0	50.0	75	95
400	75.0	72.0	72.0	75.0	70.0	65.0	57.0	50.0	75	95
430	75.0	72.0	72.0	75.0	70.0	65.0	57.0	50.0	75	95
510	77.0	74.0	74.0	77.0	72.0	67.0	59.0	52.0	77	97
520	77.0	74.0	74.0	77.0	72.0	67.0	59.0	52.0	77	97
580	77.0	74.0	74.0	77.0	72.0	67.0	59.0	52.0	77	97
700	76.0	73.0	72.0	75.0	70.0	65.0	58.0	50.0	75	96
800	76.0	73.0	73.0	75.0	70.0	66.0	58.0	50.0	75	96
940	76.0	73.0	73.0	76.0	71.0	66.0	58.0	51.0	76	97
C10	77.0	74.0	74.0	77.0	72.0	67.0	59.0	52.0	77	98
H10	77.0	74.0	73.0	76.0	71.0	66.0	59.0	51.0	76	97
C11	76.0	73.0	73.0	76.0	71.0	66.0	58.0	51.0	76	98
H12	76.0	73.0	73.0	76.0	71.0	66.0	58.0	51.0	76	98
H13	76.0	73.0	73.0	76.0	71.0	66.0	58.0	51.0	76	98
H14	77.0	74.0	73.0	76.0	71.0	66.0	59.0	51.0	76	98
H15	75.0	77.0	80.0	79.0	75.0	71.0	61.0	52.0	80	103
H16	75.0	77.0	80.0	79.0	75.0	70.0	61.0	52.0	80	103
C17	75.0	77.0	80.0	79.0	75.0	70.0	61.0	52.0	80	103
H18	75.0	77.0	80.0	79.0	75.0	70.0	61.0	52.0	80	103
C19	75.0	77.0	80.0	79.0	75.0	70.0	61.0	52.0	80	103
C20	75.0	77.0	80.0	79.0	75.0	71.0	61.0	52.0	80	103
C21	75.0	77.0	80.0	79.0	75.0	71.0	61.0	52.0	80	103

Sound power level (referred to evaporator 12/7°C, ambient 35°C full load operation) are measured in accordance with ISO 9614 and Eurovent 8/1 for Eurovent certified units. The certification refers only to the overall sound power level.
The sound data in the Octave band spectrum is for intended for reference only and not considering binding.
The sound pressure is calculated from the sound power level and are for information only and not considered binding.
The data are referred to the standard unit without options.

EWAD~T-SRB

MODEL	Sound pressure level at 1 m from the unit (rif. 2 x 10 ⁻⁵ Pa)									Power db(A)
	63 Hz	125 Hz	250 Hz	500 Hz	1000 Hz	2000 Hz	4000 Hz	8000 Hz	db(A)	
700	70.0	67.0	67.0	70.0	65.0	60.0	52.0	45.0	70	91
800	70.0	67.0	67.0	70.0	65.0	60.0	52.0	45.0	70	91
940	70.0	67.0	67.0	70.0	65.0	60.0	52.0	45.0	70	91
C10	71.0	68.0	68.0	71.0	66.0	61.0	53.0	46.0	71	92
H10	71.0	68.0	68.0	71.0	66.0	61.0	53.0	46.0	71	92
C11	70.0	67.0	67.0	70.0	65.0	60.0	52.0	45.0	70	92
H12	70.0	67.0	67.0	70.0	65.0	60.0	52.0	45.0	70	92
H13	71.0	68.0	68.0	71.0	66.0	61.0	53.0	46.0	71	93
H14	71.0	68.0	68.0	71.0	66.0	61.0	53.0	46.0	71	93
H15	67.0	69.0	72.0	71.0	67.0	63.0	53.0	44.0	72	95
H16	67.0	69.0	72.0	71.0	67.0	63.0	53.0	44.0	72	95
C17	67.0	69.0	72.0	71.0	67.0	63.0	53.0	44.0	72	95
H18	68.0	70.0	72.0	72.0	68.0	63.0	53.0	44.0	73	95
C19	68.0	70.0	73.0	72.0	68.0	63.0	54.0	45.0	73	96
C20	68.0	70.0	72.0	72.0	68.0	63.0	53.0	44.0	73	96
C21	67.0	70.0	72.0	72.0	67.0	63.0	53.0	44.0	73	96

Sound power level (referred to evaporator 12/7°C, ambient 35°C full load operation) are measured in accordance with ISO 9614 and Eurovent 8/1 for Eurovent certified units. The certification refers only to the overall sound power level.

The sound data in the Octave band spectrum is for intended for reference only and not considering binding.

The sound pressure is calculated from the sound power level and are for information only and not considered binding.

The data are referred to the standard unit without options.

EWAD~T-XSB

MODEL	Sound pressure level at 1 m from the unit (rif. 2 x 10 ⁻⁵ Pa)									Power db(A)
	63 Hz	125 Hz	250 Hz	500 Hz	1000 Hz	2000 Hz	4000 Hz	8000 Hz	db(A)	
350	78.0	75.0	75.0	78.0	73.0	68.0	60.0	53.0	78	98
380	78.0	75.0	75.0	78.0	73.0	68.0	60.0	53.0	78	98
400	78.0	75.0	75.0	78.0	73.0	68.0	60.0	53.0	78	98
420	78.0	75.0	75.0	78.0	73.0	68.0	60.0	53.0	78	98
440	78.0	75.0	75.0	78.0	73.0	68.0	60.0	53.0	78	98
490	81.0	78.0	78.0	81.0	76.0	71.0	63.0	56.0	81	101
540	80.0	77.0	77.0	80.0	75.0	70.0	62.0	55.0	80	101
570	80.0	77.0	77.0	80.0	75.0	70.0	62.0	55.0	80	101
730	78.0	75.0	75.0	78.0	73.0	68.0	60.0	53.0	78	99
820	78.0	75.0	75.0	78.0	73.0	68.0	60.0	53.0	78	99
950	78.0	75.0	75.0	78.0	73.0	68.0	60.0	53.0	78	100
C10	79.0	76.0	76.0	78.0	73.0	69.0	61.0	53.0	78	100
H10	79.0	76.0	75.0	78.0	73.0	68.0	61.0	53.0	78	100
H11	79.0	76.0	76.0	78.0	73.0	69.0	61.0	53.0	79	101
C13	79.0	76.0	76.0	78.0	73.0	69.0	61.0	53.0	79	101
H13	79.0	76.0	76.0	79.0	73.0	69.0	61.0	54.0	79	101
C14	79.0	76.0	76.0	79.0	74.0	69.0	61.0	54.0	79	101
H15	75.0	77.0	80.0	79.0	75.0	70.0	61.0	52.0	80	103
H16	75.0	77.0	79.0	79.0	75.0	70.0	60.0	51.0	80	103
C17	74.0	76.0	79.0	78.0	74.0	70.0	60.0	51.0	79	103
H18	74.0	76.0	79.0	78.0	74.0	70.0	60.0	51.0	79	103
C19	75.0	77.0	79.0	79.0	75.0	70.0	60.0	51.0	80	103
C20	75.0	77.0	80.0	79.0	75.0	70.0	61.0	52.0	80	103

Sound power level (referred to evaporator 12/7°C, ambient 35°C full load operation) are measured in accordance with ISO 9614 and Eurovent 8/1 for Eurovent certified units. The certification refers only to the overall sound power level.

The sound data in the Octave band spectrum is for intended for reference only and not considering binding.

The sound pressure is calculated from the sound power level and are for information only and not considered binding.

The data are referred to the standard unit without options.

EWAD~T-XLB

MODEL	Sound pressure level at 1 m from the unit (rif. 2×10^{-5} Pa)									Power db(A)
	63 Hz	125 Hz	250 Hz	500 Hz	1000 Hz	2000 Hz	4000 Hz	8000 Hz	db(A)	
350	75.0	72.0	72.0	75.0	69.0	65.0	57.0	50.0	75	95
380	75.0	72.0	72.0	75.0	69.0	65.0	57.0	50.0	75	95
400	75.0	72.0	72.0	75.0	70.0	65.0	57.0	50.0	75	95
420	75.0	72.0	72.0	75.0	70.0	65.0	57.0	50.0	75	95
440	75.0	72.0	72.0	75.0	70.0	65.0	57.0	50.0	75	95
490	77.0	74.0	74.0	77.0	72.0	67.0	59.0	52.0	77	97
540	76.0	73.0	73.0	76.0	71.0	66.0	58.0	51.0	76	97
570	76.0	73.0	73.0	76.0	71.0	66.0	58.0	51.0	76	97
730	76.0	73.0	73.0	76.0	71.0	66.0	58.0	51.0	76	97
820	77.0	74.0	74.0	76.0	71.0	67.0	59.0	51.0	76	97
950	76.0	73.0	73.0	76.0	71.0	66.0	58.0	51.0	76	98
C10	77.0	74.0	74.0	76.0	71.0	67.0	59.0	51.0	76	98
H10	76.0	73.0	73.0	76.0	71.0	66.0	58.0	51.0	76	98
H11	76.0	73.0	73.0	76.0	71.0	66.0	58.0	51.0	76	98
C13	77.0	74.0	74.0	76.0	71.0	67.0	59.0	51.0	77	99
H13	77.0	74.0	74.0	77.0	72.0	67.0	59.0	52.0	77	99
C14	77.0	74.0	74.0	77.0	72.0	67.0	59.0	52.0	77	99
H15	75.0	77.0	80.0	79.0	75.0	70.0	61.0	52.0	80	103
H16	75.0	77.0	79.0	79.0	75.0	70.0	60.0	51.0	80	103
C17	74.0	76.0	79.0	78.0	74.0	70.0	60.0	51.0	79	103
H18	74.0	76.0	79.0	78.0	74.0	70.0	60.0	51.0	79	103
C19	75.0	77.0	79.0	79.0	75.0	70.0	60.0	51.0	80	103
C20	75.0	77.0	80.0	79.0	75.0	70.0	61.0	52.0	80	103

Sound power level (referred to evaporator 12/7°C, ambient 35°C full load operation) are measured in accordance with ISO 9614 and Eurovent 8/1 for Eurovent certified units. The certification refers only to the overall sound power level.

The sound data in the Octave band spectrum is for intended for reference only and not considering binding.

The sound pressure is calculated from the sound power level and are for information only and not considered binding.

The data are referred to the standard unit without options.

EWAD~T-XRB

MODEL	Sound pressure level at 1 m from the unit (rif. 2 x 10 ⁻⁵ Pa)									Power db(A)
	63 Hz	125 Hz	250 Hz	500 Hz	1000 Hz	2000 Hz	4000 Hz	8000 Hz	db(A)	
730	70.0	67.0	67.0	70.0	65.0	60.0	52.0	45.0	70	91
820	70.0	67.0	67.0	70.0	65.0	60.0	52.0	45.0	70	91
950	70.0	67.0	67.0	70.0	65.0	60.0	52.0	45.0	70	92
C10	71.0	68.0	68.0	70.0	65.0	61.0	53.0	45.0	70	92
H10	71.0	68.0	67.0	70.0	65.0	60.0	53.0	45.0	70	92
H11	71.0	68.0	68.0	71.0	66.0	61.0	53.0	46.0	71	93
C13	71.0	68.0	68.0	70.0	65.0	61.0	53.0	45.0	71	93
H13	71.0	68.0	68.0	70.0	65.0	61.0	53.0	45.0	71	93
C14	71.0	68.0	68.0	71.0	66.0	61.0	53.0	46.0	71	93
H15	71.0	64.0	71.0	77.0	64.0	60.0	52.0	40.0	75	97
H16	71.0	64.0	71.0	76.0	64.0	60.0	52.0	39.0	74	97
C17	71.0	64.0	71.0	76.0	63.0	60.0	52.0	39.0	74	97
H18	70.0	64.0	71.0	76.0	63.0	60.0	51.0	39.0	74	97
C19	71.0	64.0	71.0	76.0	64.0	60.0	52.0	39.0	74	98
C20	71.0	64.0	71.0	77.0	64.0	60.0	52.0	40.0	74	98

Sound power level (referred to evaporator 12/7°C, ambient 35°C full load operation) are measured in accordance with ISO 9614 and Eurovent 8/1 for Eurovent certified units. The certification refers only to the overall sound power level.
The sound data in the Octave band spectrum is for intended for reference only and not considering binding.
The sound pressure is calculated from the sound power level and are for information only and not considered binding.
The data are referred to the standard unit without options.

Operating limits

EWAD~T -B SS/SL/SR

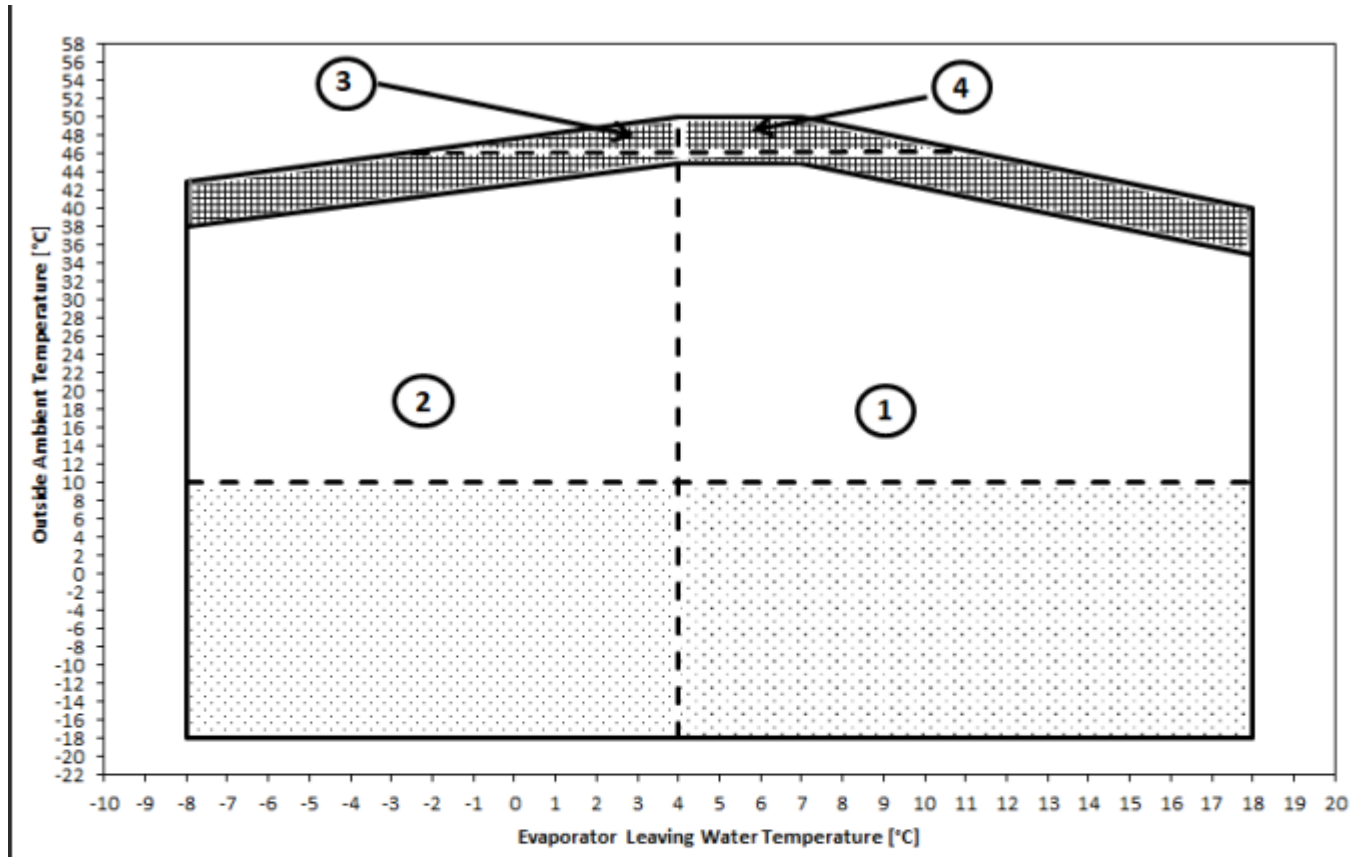

IN THIS AREA CHILLER WILL RUN AT PART LOAD

SPEEDTROL (OPTION 42) or FAN SPEED REGULATION (OPTION 99a) REQUIRED

Ref.1: standard unit (no options are required to operate in this area)

Ref.2: standard unit + opt. 08 (Brine) (chiller may not unload to minimum load)

Ref.3: standard unit + opt. 142 (High Ambient Kit) + opt. 08 (Brine) (chiller may not unload to minimum load)

Ref.4: standard unit + opt. 142 (High Ambient Kit)

NOTE:

-For operation with ELWT below 4°C, the unit must operate with glycol mixture. The glycol percentage must be provide according to the minimum ELWT needed.

-The above graphic represents a guideline about the operating limits of the range. Please refer to the latest Chiller Selection Software (CSS) for real operating limits working conditions for each size.

-In area 2 and 3 chiller may not unload to the minimum load.

Operating limits
EWAD~T -B XS/XL/XR

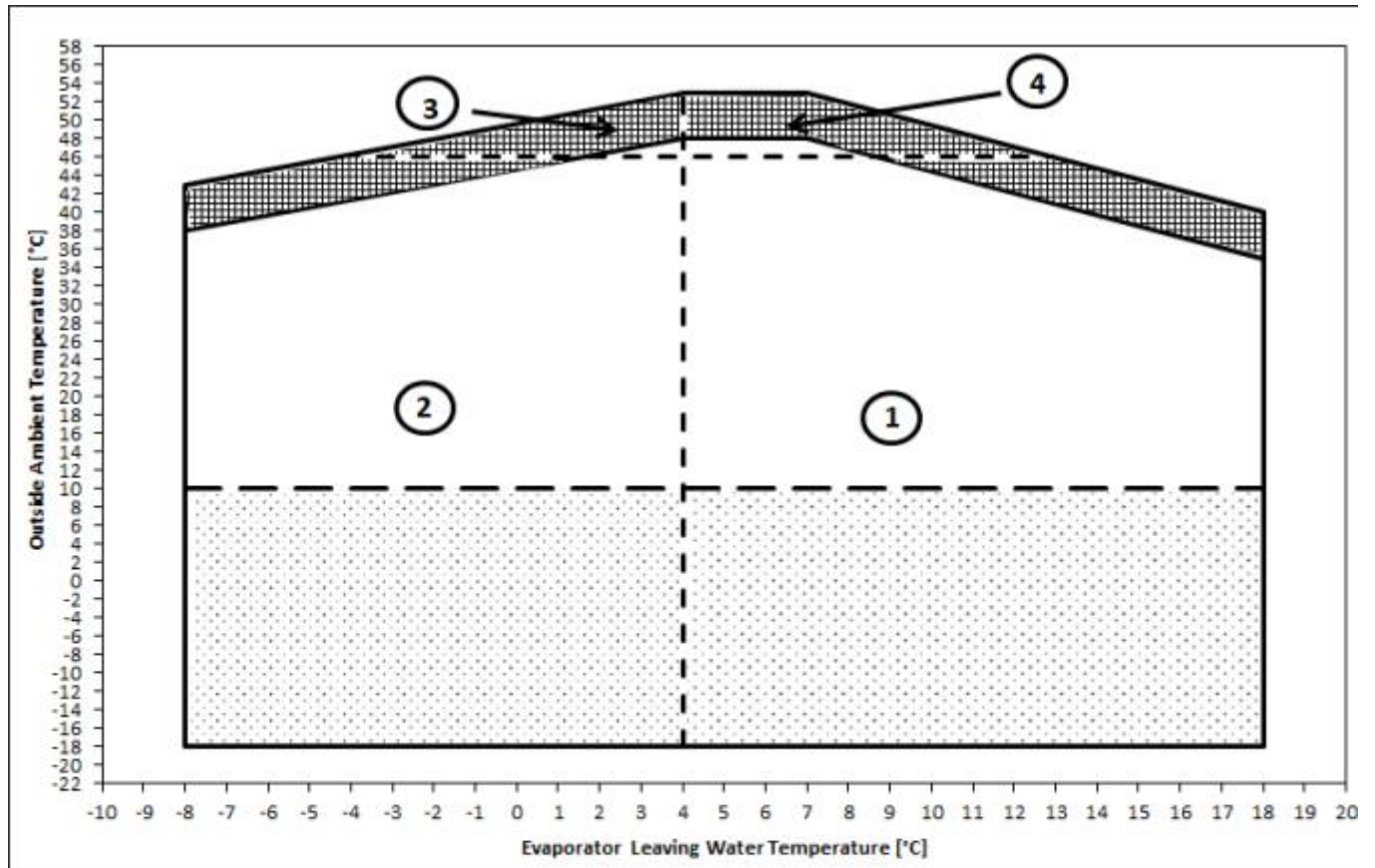

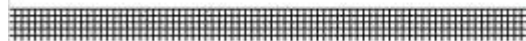
 IN THIS AREA CHILLER WILL RUN AT PART LOAD

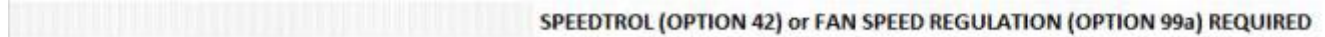
 SPEEDTROL (OPTION 42) or FAN SPEED REGULATION (OPTION 99a) REQUIRED

Ref.1: standard unit (no options are required to operate in this area)

Ref.2: standard unit + opt. 08 (Brine) (chiller may not unload to minimum load)

Ref.3: standard unit + opt. 142 (High Ambient Kit) + opt. 08 (Brine) (chiller may not unload to minimum load)

Ref.4: standard unit + opt. 142 (High Ambient Kit)

NOTE:

-For operation with ELWT below 4°C, the unit must operate with glycol mixture. The glycol percentage must be provide according to the minimum ELWT needed.

-The above graphic represents a guideline about the operating limits of the range. Please refer to the latest Chiller Selection Software (CSS) for real operating limits working conditions for each size.

-In area 2 and 3 chiller may not unload to the minimum load.

Minimum water flow

In the following tables are indicated the minimum water flow allowed for each model. In case of variable flow application where the speed of the pump is managed by an external BMS (through 0- 10V signal) the change in water flow rate must not be exceeded more than 10% of the design water flow rate per minute.

The above values are referred to pure water (in case of glycol mixture contact factory).

Note: the performance are certified at standard conditions and with the unit operating with the nominal water flow (corresponding to OAT 35°C; water in/out 12/7°C)

EWAD-TB SS/SL B2	min. water flow [l/s]
EWAD290T-SS/SL B2	6,44
EWAD330T-SS/SL B2	6,44
EWAD370T-SS/SL B2	5,33
EWAD400T-SS/SL B2	6,31
EWAD430T-SS/SL B2	7,53
EWAD510T-SS/SL B2	9,53
EWAD520T-SS/SL B2	7,53
EWAD580T-SS/SL B2	7,53

EWAD-TB XS/XL B2	min. water flow [l/s]
EWAD350T-XS/XL B2	7,44
EWAD380T-XS/XL B2	7,44
EWAD400T-XS/XL B2	7,44
EWAD420T-XS/XL B2	9,53
EWAD440T-XS/XL B2	9,53
EWAD490T-XS/XL B2	7,53
EWAD540T-XS/XL B2	9,53
EWAD570T-XS/XL B2	9,53

EWAD-TB SS/SL/SR B2	min. water flow [l/s]
EWAD700T-SS/SL/SR B2	12,4
EWAD800T-SS/SL/SR B2	14,28
EWAD940T-SS/SL/SR B2	16,78
EWADC10T-SS/SL/SR B2	17,61
EWADH10T-SS/SL/SR B2	18,54
EWADC11T-SS/SL/SR B2	19,98
EWADH12T-SS/SL/SR B2	22,31
EWADH13T-SS/SL/SR B2	23,94
EWADH14T-SS/SL/SR B2	25,64
EWADH15T-SS/SL/SR B3	27,89
EWADH16T-SS/SL/SR B3	27,89
EWADC17T-SS/SL/SR B3	27,89
EWADH18T-SS/SL/SR B3	30,50
EWADC19T-SS/SL/SR B3	30,50
EWADC20T-SS/SL/SR B3	33,14
EWADC21T-SS/SL/SR B3	33,14

EWAD-TB XS/XL/XR B2	min. water flow [l/s]
EWAD730T-XS/XL/XR B2	15,72
EWAD820T-XS/XL/XR B2	18,58
EWAD950T-XS/XL/XR B2	22,17
EWADC10T-XS/XL/XR B2	22,17
EWADH10T-XS/XL/XR B2	27,89
EWADH11T-XS/XL/XR B2	27,89
EWADC13T-XS/XL/XR B2	23,01
EWADH13T-XS/XL/XR B2	24,42
EWADC14T-XS/XL/XR B2	27,89
EWADH15T-XS/XL/XR B3	27,89
EWADH16T-XS/XL/XR B3	27,89
EWADC17T-XS/XL/XR B3	30,50
EWADH18T-XS/XL/XR B3	30,50
EWADC19T-XS/XL/XR B3	33,14
EWADC20T-XS/XL/XR B3	33,14

Water heat exchanger - maximum/maximum water ΔT

The minimum and maximum allowed ΔT at full load conditions are respectively 4 °C and 9°C. Contact factory in case lower or higher ΔT are required.

Minimum glycol percentage for low air ambient temperature to prevent freezing of the hydraulic circuit

Ambient temperature [°C]	-3	-8	-15	-20
Ethylene glycol [%]	10%	20%	30%	40%
Ambient temperature [°C]	-3	-7	-12	-20
Propylene glycol [%]	10%	20%	30%	40%

In presence of glycol in the water system the performance will be affected. Refer to the selection software. All machine protection systems, such as antifreeze, and low-pressure protection will need to be adjusted in accordance to the type and percentage of the glycol.

Operating limits for Storage Environmental conditions must be within the following limits:

- Minimum ambient temperature : -20°C
- Maximum ambient temperature : 57°C
- Maximum R.H. : 95% not condensing.

Storage below the minimum temperature may cause damage to components. Storage above the maximum temperature causes opening of safety valves.

Storage in condensing atmosphere may damage electronic components.

Heat recovery Units may be optionally equipped with heat recovery system. This system is made by a water cooled heat exchanger located on the compressors discharge pipe and a dedicated management of condensing pressure.

To guarantee compressor operation within its envelope, units with heat recovery cannot operate with water temperature of the heat recovery water lower than 25°C.

It is a responsibility of plant designer and chiller installer to guarantee the respect of this value (e.g. using recirculating bypass valve).

Water treatment Before unit start up, clean the water circuit. Dirt, scales, corrosion debris and other material can accumulate inside the heat exchanger and reduce its heat exchanging capacity. Pressure drop can increase as well, thus reducing water flow. Proper water treatment therefore reduces the risk of corrosion, erosion, scaling, etc.. The most appropriate water treatment must be determined locally, according to the type of system and water characteristics. The manufacturer is not responsible for damage or malfunctioning of equipment caused by improperly treated water.

Water charge, flow and quality

Items (1) (6)	Cooling System				Cooled Water		Heated water (2)		Tendency if out of criteria	
	Circulating System		Once Flow	Cooled Water		Low temperature		High temperature		
	Circulating water	Supply water (4)	Flowing water	Circulating water [Below 20°C]	Supply water (4)	Circulating water [20°C - 60°C]	Supply water (4)	Circulating water [60°C - 80°C]		Supply water (4)
pH	6.5 - 8.2	5.0 - 8.0	5.0 - 8.0	5.8 - 8.0	5.0 - 8.0	7.0 - 8.0	7.0 - 8.0	7.0 - 8.0	7.0 - 8.0	Corrosion + Scale
Electrical conductivity	Below 80 (Below 800)	Below 30 (Below 300)	Below 40 (Below 400)	Below 80 (Below 800)	Below 80 (Below 800)	Below 30 (Below 300)	Below 30 (Below 300)	Below 30 (Below 300)	Below 30 (Below 300)	Corrosion + Scale
Chloride ion	Below 200 [mgCl ⁻ /l]	Below 50	Below 50	Below 200 [mgCl ⁻ /l]	Below 50	Below 50	Below 50	Below 30	Below 30	Corrosion
Sulfate ion	Below 200 [mgSO ₄ ²⁻ /l]	Below 50	Below 50	Below 200 [mgSO ₄ ²⁻ /l]	Below 50	Below 50	Below 50	Below 30	Below 30	Corrosion
Alkalinity (pH 8)	Below 100 [mgCaCO ₃ /l]	Below 50	Below 50	Below 100 [mgCaCO ₃ /l]	Below 50	Below 50	Below 50	Below 50	Below 50	Scale
Total hardness	Below 200 [mgCaCO ₃ /l]	Below 70	Below 70	Below 200 [mgCaCO ₃ /l]	Below 70	Below 70	Below 70	Below 70	Below 70	Scale
Calcium hardness	Below 150 [mgCaCO ₃ /l]	Below 50	Below 50	Below 50 [mgCaCO ₃ /l]	Below 50	Below 50	Below 50	Below 50	Below 50	Scale
Silica ion	Below 50 [mgSiO ₂ /l]	Below 30	Below 30	Below 30 [mgSiO ₂ /l]	Below 30	Below 30	Below 30	Below 30	Below 30	Scale
Oxygen	Below 1.0 (mg O ₂ / l)	Below 1.0	Below 1.0	Below 1.0 [mg O ₂ / l]	Below 1.0	Below 1.0	Below 1.0	Below 1.0	Below 1.0	Corrosion
Particulate size	Below 0.5 (mm)	Below 0.5	Below 0.5	Below 0.5 (mm)	Below 0.5	Below 0.5	Below 0.5	Below 0.5	Below 0.5	Erosion
Total dissolved solids	Below 1000 (mg / l)	Below 1000	Below 1000	Below 1000 (mg / l)	Below 1000	Below 1000	Below 1000	Below 1000	Below 1000	Erosion
Ethylene, Propylene Glycol (weight conc.)	Below 60%	Below 60%	---	Below 60%	Below 60%	Below 60%	Below 60%	Below 60%	Below 60%	---
Nitrate ion	Below 100 (mg NO ₃ - / l)	Below 100	Below 100	Below 100 (mg NO ₃ - / l)	Below 100	Below 100	Below 100	Below 100	Below 100	Corrosion
TOC Total organic carbon	Below 1.0 (mg / l)	Below 1.0	Below 1.0	Below 1.0 (mg / l)	Below 1.0	Below 1.0	Below 1.0	Below 1.0	Below 1.0	Scale
Iron	Below 1.0 [mgFe ²⁺ /l]	Below 0.3	Below 1.0	Below 1.0 [mgFe ²⁺ /l]	Below 0.3	Below 0.3	Below 0.3	Below 0.3	Below 0.3	Corrosion + Scale
Copper	Below 0.3 [mgCu ²⁺ /l]	Below 0.1	Below 1.0	Below 1.0 [mgCu ²⁺ /l]	Below 0.1	Below 0.1	Below 0.1	Below 0.1	Below 0.1	Corrosion
Sulfate ion	Not detectable [mgS ²⁻ /l]	Not detectable	Not detectable	Not detectable [mgS ²⁻ /l]	Not detectable	Not detectable	Not detectable	Not detectable	Not detectable	Corrosion
Ammonium ion	Below 1.0 [mgNH ₄ ⁺ /l]	Below 0.1	Below 1.0	Below 1.0 [mgNH ₄ ⁺ /l]	Below 0.1	Below 0.1	Below 0.1	Below 0.1	Below 0.1	Corrosion
Remaining chloride	Below 0.3 [mgCl ⁻ /l]	Below 0.3	Below 0.3	Below 0.3 [mgCl ⁻ /l]	Below 0.3	Below 0.3	Below 0.3	Below 0.3	Below 0.3	Corrosion
Free carbide	Below 4.0 [mgCO ₂ /l]	Below 4.0	Below 4.0	Below 4.0 [mgCO ₂ /l]	Below 4.0	Below 4.0	Below 4.0	Below 4.0	Below 4.0	Corrosion
Stability index	6.0 - 7.0	---	---	---	---	---	---	---	---	Corrosion + Scale

Items to be controlled:

Items to be referred to:

- Names, definitions and units are according to JIS K 0101. Units and figures between brackets are old units published as reference only.
- In case of using heated water (more than 40°C), corrosion is generally noticeable. Especially when the iron materials is in direct contact with water without any protection shields, it is desirable to give the valid measure for corrosion. E.g. chemical measure
- In the cooling water using hermetic cooling tower, close circuit water is according to heated water standard, and scattered water is according to cooling water standard.
- Supply water is considered drink water, industrial water and ground water except for genuine water, neutral water and soft water.
- The above mentioned items are representable items in corrosion and scale cases.
- The limits above have to be considered as a general prescription and can not totally assure the absence of corrosion and erosion. Some particular combinations of elements or the presence of components not listed in the table or factors not considered may trigger corrosion phenomena.

Single pump low lift

EWAD T B S/X-S/L/R 300-700 kW (SILVER & GOLD series) – Available static pressure

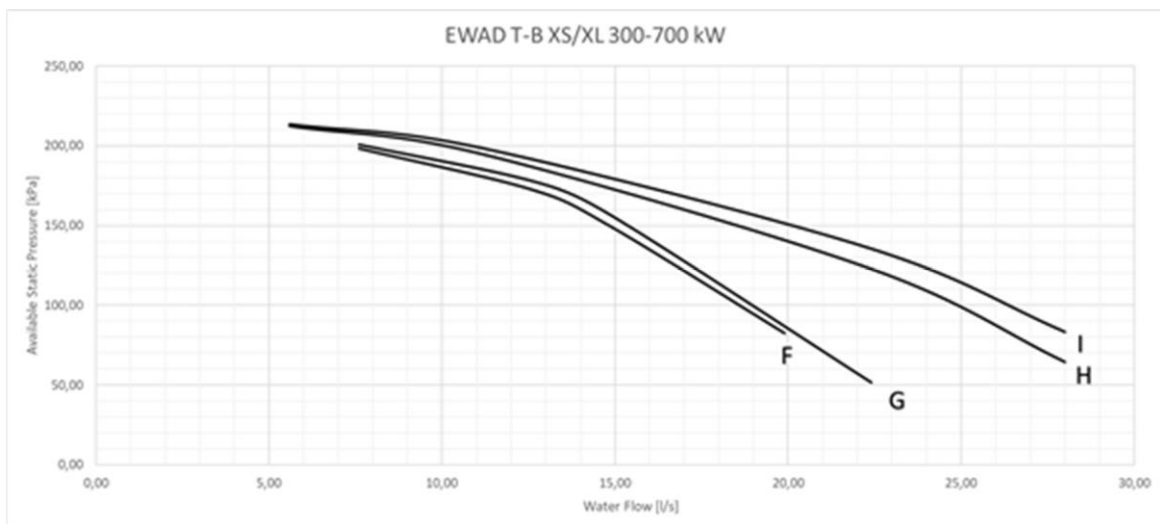
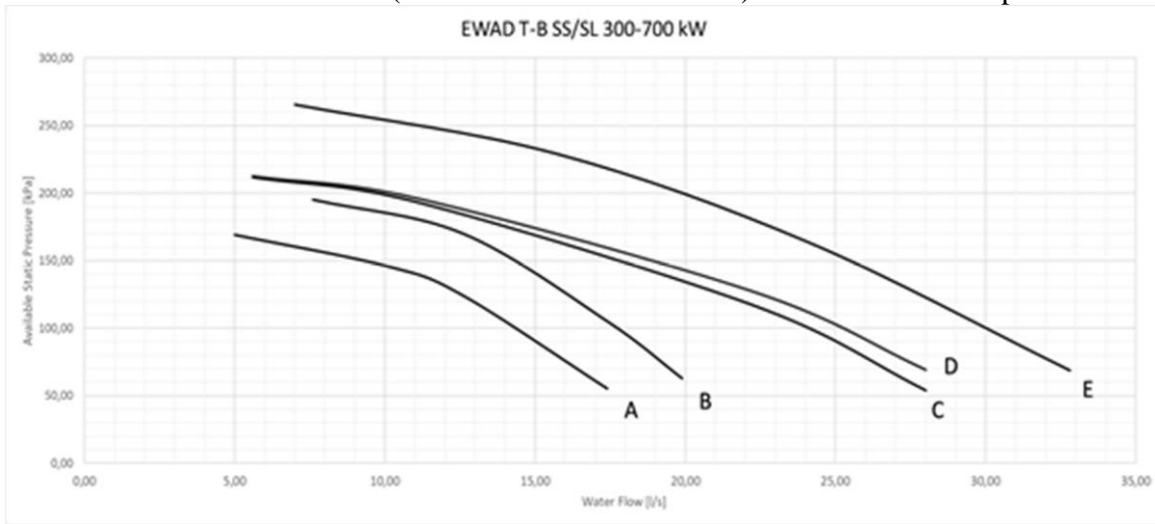

Model		Pump Motor Power [kW]	Pump Motor Current [A]	Power supply	PN	Motor protection	Insulation class	Working temperature [°C]	Max ambient temperatures [°C]	Ref. Curve
EWAD290T-SSB2	EWAD290T-SLB2	3	6,3	400V-3ph-50Hz	16	IP55	F	-25/+120	40	A
EWAD330T-SSB2	EWAD330T-SLB2	3	6,3	400V-3ph-50Hz	16	IP55	F	-25/+120	40	A
EWAD370T-SSB2	EWAD370T-SLB2	4	7,7	400V-3ph-50Hz	16	IP55	F	-25/+120	40	B
EWAD400T-SSB2	EWAD400T-SLB2	5,5	10,5	400V-3ph-50Hz	16	IP55	F	-25/+120	40	C
EWAD430T-SSB2	EWAD430T-SLB2	5,5	10,5	400V-3ph-50Hz	16	IP55	F	-25/+120	40	C
EWAD510T-SSB2	EWAD510T-SLB2	5,5	10,5	400V-3ph-50Hz	16	IP55	F	-25/+120	40	D
EWAD520T-SSB2	EWAD520T-SLB2	5,5	10,5	400V-3ph-50Hz	16	IP55	F	-25/+120	40	D
EWAD580T-SSB2	EWAD580T-SLB2	7,5	14,1	400V-3ph-50Hz	16	IP55	F	-25/+120	40	E
EWAD350T-XSB2	EWAD350T-XLB2	4	7,7	400V-3ph-50Hz	16	IP55	F	-25/+120	40	F
EWAD380T-XSB2	EWAD380T-XLB2	4	7,7	400V-3ph-50Hz	16	IP55	F	-25/+120	40	F
EWAD400T-XSB2	EWAD400T-XLB2	4	7,7	400V-3ph-50Hz	16	IP55	F	-25/+120	40	F
EWAD420T-XSB2	EWAD420T-XLB2	4	7,7	400V-3ph-50Hz	16	IP55	F	-25/+120	40	G
EWAD440T-XSB2	EWAD440T-XLB2	5,5	10,5	400V-3ph-50Hz	16	IP55	F	-25/+120	40	I
EWAD490T-XSB2	EWAD490T-XLB2	5,5	10,5	400V-3ph-50Hz	16	IP55	F	-25/+120	40	H
EWAD540T-XSB2	EWAD540T-XLB2	5,5	10,5	400V-3ph-50Hz	16	IP55	F	-25/+120	40	I
EWAD570T-XSB2	EWAD570T-XLB2	5,5	10,5	400V-3ph-50Hz	16	IP55	F	-25/+120	40	I

Note: to calculate the total electrical data of the base unit selected with hydronic kit, the electrical data of the pump must be added to the electrical data of the base unit. Electrical data are subject to modification without notice. Please refer to unit nameplate.

Single pump low lift

EWAD T B S/X-S/L/R 700-1400 kW (SILVER & GOLD series) – Available static pressure

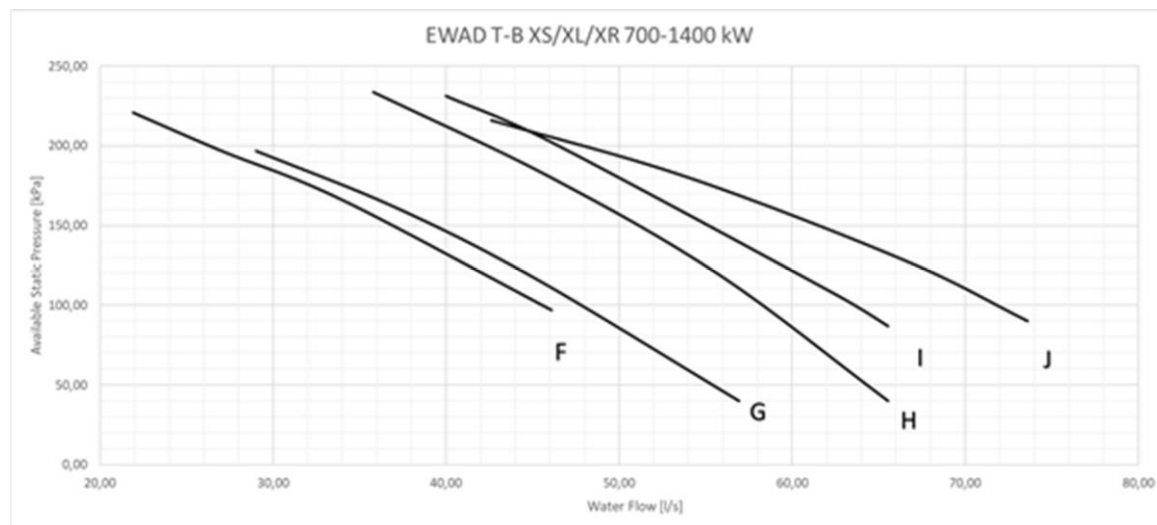
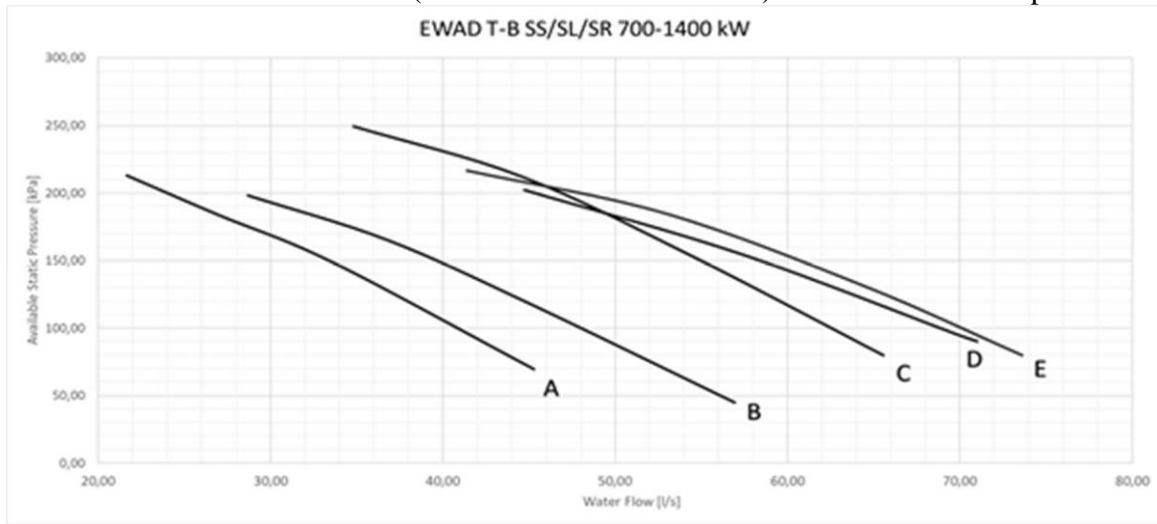

Model			Pump Motor Power [kW]	Pump Motor Current [A]	Power supply	PN	Motor protection	Insulation class	Working temperature °[C]	Max ambient temperatures [C°]	Ref. Curve
EWAD700T-S5B2	EWAD700T-SLB2	EWAD700T-SRB2	11	20,2	400V-3ph-50Hz	16	IP55	F	-25/+120	40	A
EWAD800T-S5B2	EWAD800T-SLB2	EWAD800T-SRB2	11	20,2	400V-3ph-50Hz	16	IP55	F	-25/+120	40	B
EWAD940T-S5B2	EWAD940T-SLB2	EWAD940T-SRB2	11	20,2	400V-3ph-50Hz	16	IP55	F	-25/+120	40	B
EWADC10T-S5B2	EWADC10T-SLB2	EWADC10T-SRB2	11	20,2	400V-3ph-50Hz	16	IP55	F	-25/+120	40	B
EWADH10T-S5B2	EWADH10T-SLB2	EWADH10T-SRB2	11	20,2	400V-3ph-50Hz	16	IP55	F	-25/+120	40	B
EWADC11T-S5B2	EWADC11T-SLB2	EWADC11T-SRB2	15	26,6	400V-3ph-50Hz	16	IP55	F	-25/+120	40	C
EWADH12T-S5B2	EWADH12T-SLB2	EWADH12T-SRB2	15	26,6	400V-3ph-50Hz	16	IP55	F	-25/+120	40	C
EWADH13T-S5B2	EWADH13T-SLB2	EWADH13T-SRB2	15	26	400V-3ph-50Hz	16	IP55	F	-25/+120	40	D
EWADH14T-S5B2	EWADH14T-SLB2	EWADH14T-SRB2	15	26	400V-3ph-50Hz	16	IP55	F	-25/+120	40	E
EWAD730T-X5B2	EWAD730T-XLB2	EWAD730T-XRB2	11	20,2	400V-3ph-50Hz	16	IP55	F	-25/+120	40	F
EWAD820T-X5B2	EWAD820T-XLB2	EWAD820T-XRB2	11	20,2	400V-3ph-50Hz	16	IP55	F	-25/+120	40	F
EWAD950T-X5B2	EWAD950T-XLB2	EWAD950T-XRB2	11	20,2	400V-3ph-50Hz	16	IP55	F	-25/+120	40	G
EWADC10T-X5B2	EWADC10T-XLB2	EWADC10T-XRB2	11	20,2	400V-3ph-50Hz	16	IP55	F	-25/+120	40	G
EWADH10T-X5B2	EWADH10T-XLB2	EWADH10T-XRB2	15	26,6	400V-3ph-50Hz	16	IP55	F	-25/+120	40	H
EWADH11T-X5B2	EWADH11T-XLB2	EWADH11T-XRB2	15	26,6	400V-3ph-50Hz	16	IP55	F	-25/+120	40	H
EWADC13T-X5B2	EWADC13T-XLB2	EWADC13T-XRB2	15	26,6	400V-3ph-50Hz	16	IP55	F	-25/+120	40	I
EWADH13T-X5B2	EWADH13T-XLB2	EWADH13T-XRB2	15	26	400V-3ph-50Hz	16	IP55	F	-25/+120	40	J
EWADC14T-X5B2	EWADC14T-XLB2	EWADC14T-XRB2	15	26	400V-3ph-50Hz	16	IP55	F	-25/+120	40	J

Note: to calculate the total electrical data of the base unit selected with hydronic kit, the electrical data of the pump must be added to the electrical data of the base unit. Electrical data are subject to modification without notice. Please refer to unit nameplate.

Single pump high lift

EWAD T B S/X-S/L/R 300-700 kW(SILVER & GOLD series) – Available static pressure

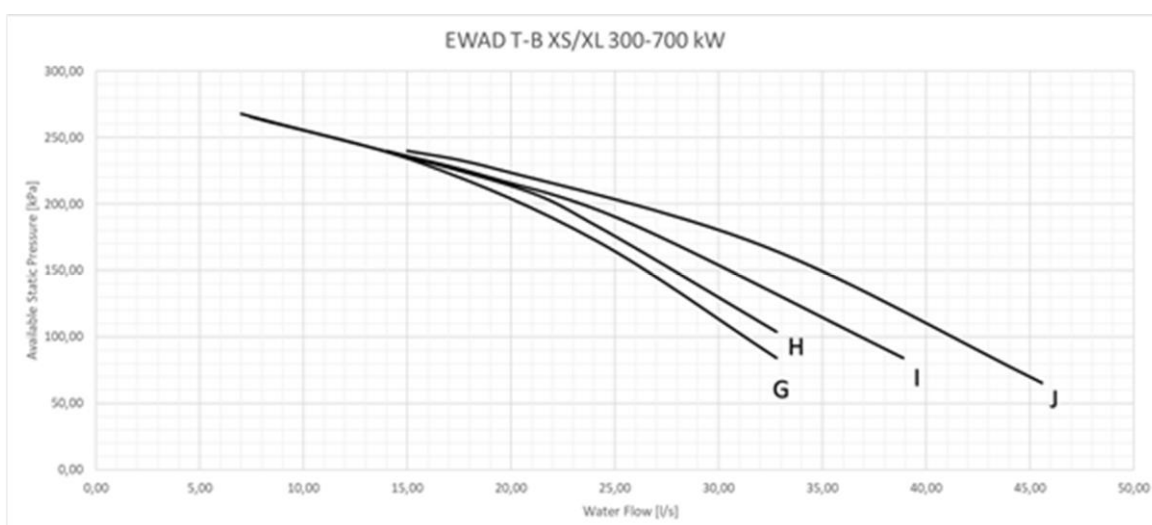
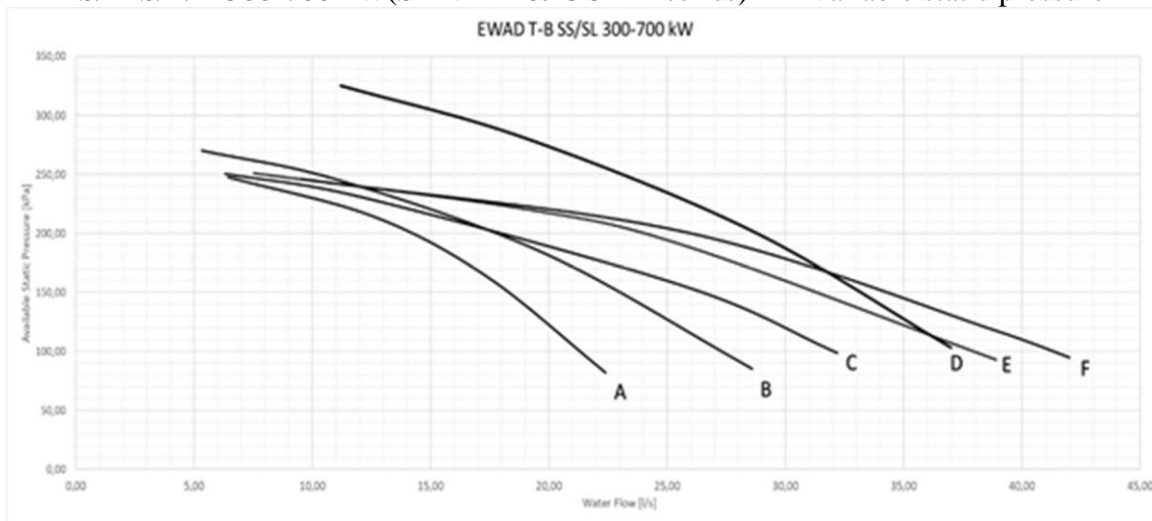

Model		Pump Motor Power [kW]	Pump Motor Current [A]	Power supply	PN	Motor protection	Insulation class	Working temperature °[C]	Max ambient temperatures [C°]	Ref. Curve
EWAD290T-SSB2	EWAD290T-SLB2	5,5	10,5	400V-3ph-50Hz	16	IP55	F	-25/+120	40	A
EWAD330T-SSB2	EWAD330T-SLB2	5,5	10,5	400V-3ph-50Hz	16	IP55	F	-25/+120	40	A
EWAD370T-SSB2	EWAD370T-SLB2	11	20,2	400V-3ph-50Hz	16	IP55	F	-25/+120	40	B
EWAD400T-SSB2	EWAD400T-SLB2	11	20,2	400V-3ph-50Hz	16	IP55	F	-25/+120	40	C
EWAD430T-SSB2	EWAD430T-SLB2	11	20,2	400V-3ph-50Hz	16	IP55	F	-25/+120	40	E
EWAD510T-SSB2	EWAD510T-SLB2	11	20,2	400V-3ph-50Hz	16	IP55	F	-25/+120	40	E
EWAD520T-SSB2	EWAD520T-SLB2	11	20,2	400V-3ph-50Hz	16	IP55	F	-25/+120	40	D
EWAD580T-SSB2	EWAD580T-SLB2	11	20,2	400V-3ph-50Hz	16	IP55	F	-25/+120	40	F
EWAD350T-XSB2	EWAD350T-XLB2	7,5	14,1	400V-3ph-50Hz	16	IP55	F	-25/+120	40	G
EWAD380T-XSB2	EWAD380T-XLB2	7,5	14,1	400V-3ph-50Hz	16	IP55	F	-25/+120	40	G
EWAD400T-XSB2	EWAD400T-XLB2	7,5	14,1	400V-3ph-50Hz	16	IP55	F	-25/+120	40	G
EWAD420T-XSB2	EWAD420T-XLB2	7,5	14,1	400V-3ph-50Hz	16	IP55	F	-25/+120	40	H
EWAD440T-XSB2	EWAD440T-XLB2	7,5	14,1	400V-3ph-50Hz	16	IP55	F	-25/+120	40	H
EWAD490T-XSB2	EWAD490T-XLB2	11	20,2	400V-3ph-50Hz	16	IP55	F	-25/+120	40	I
EWAD540T-XSB2	EWAD540T-XLB2	11	20,2	400V-3ph-50Hz	16	IP55	F	-25/+120	40	J
EWAD570T-XSB2	EWAD570T-XLB2	11	20,2	400V-3ph-50Hz	16	IP55	F	-25/+120	40	J

Note: to calculate the total electrical data of the base unit selected with hydronic kit, the electrical data of the pump must be added to the electrical data of the base unit. Electrical data are subject to modification without notice. Please refer to unit nameplate.

Single pump high lift

EWAD T B S/X-S/L/R 700-1400 kW (SILVER & GOLD series) – Available static pressure

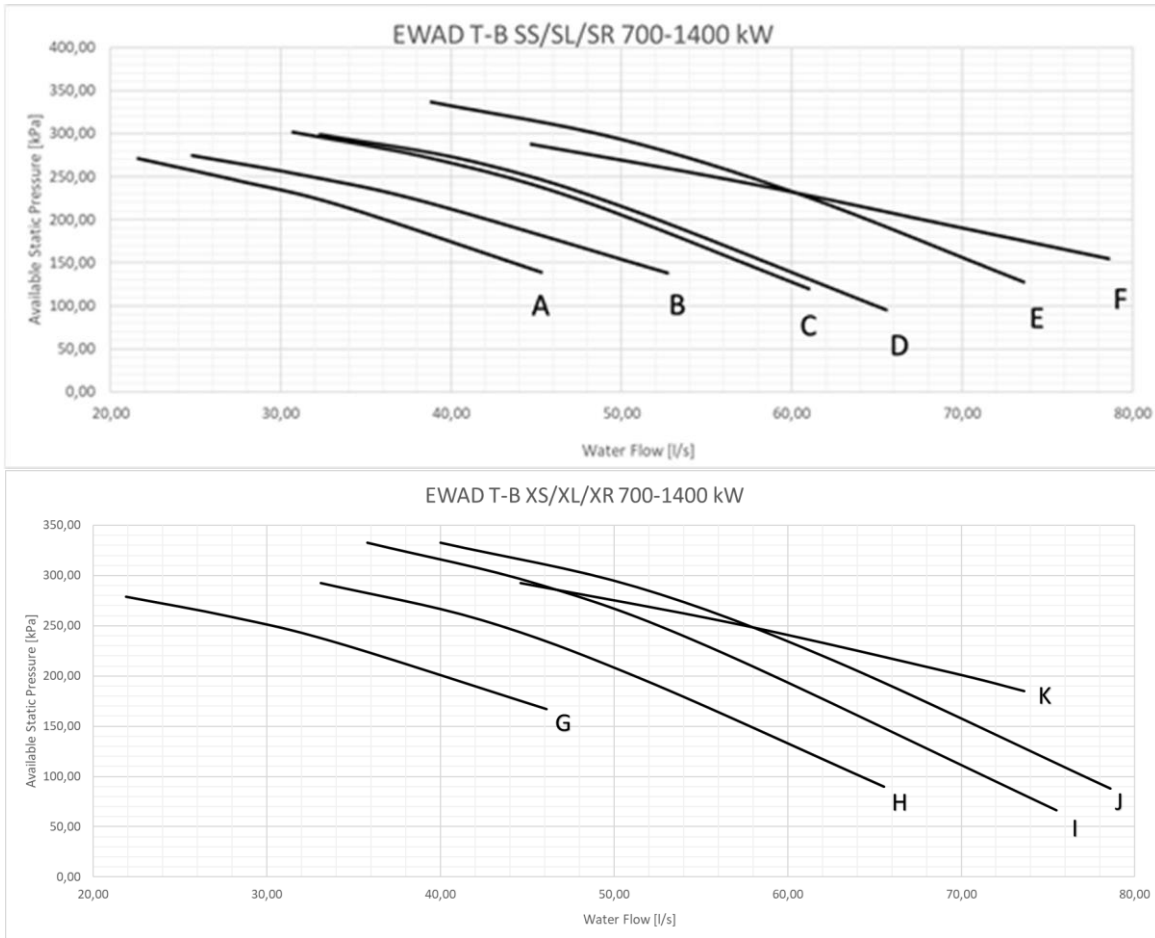

Model	Pump Motor Power [kW]	Pump Motor Current [A]	Power supply	PN	Motor protection	Insulation class	Working temperature [°C]	Max ambient temperatures [°C]	Ref. Curve
EWAD700T-SSB2	15	26,6	400V-3ph-50Hz	16	IP 55	F	-25/+120	40	A
EWAD800T-SSB2	15	26,6	400V-3ph-50Hz	16	IP 55	F	-25/+120	40	B
EWAD940T-SSB2	18,5	32,7	400V-3ph-50Hz	16	IP 55	F	-25/+120	40	C
EWADC10T-S5B2	18,5	32,7	400V-3ph-50Hz	16	IP 55	F	-25/+120	40	C
EWADH10T-SSB2	18,5	32,7	400V-3ph-50Hz	16	IP 55	F	-25/+120	40	C
EWADC11T-S5B2	18,5	32,7	400V-3ph-50Hz	16	IP 55	F	-25/+120	40	D
EWADH12T-SSB2	22	42,2	400V-3ph-50Hz	16	IP 55	F	-25/+120	40	E
EWADH13T-SSB2	22	38	400V-3ph-50Hz	16	IP 55	F	-25/+120	40	F
EWADH14T-SSB2	22	38	400V-3ph-50Hz	16	IP 55	F	-25/+120	40	F
EWAD730T-XSB2	15	26,6	400V-3ph-50Hz	16	IP 55	F	-25/+120	40	G
EWAD820T-XSB2	15	26,6	400V-3ph-50Hz	16	IP 55	F	-25/+120	40	G
EWAD950T-XSB2	18,5	32,7	400V-3ph-50Hz	16	IP 55	F	-25/+120	40	H
EWADC10T-X5B2	18,5	32,7	400V-3ph-50Hz	16	IP 55	F	-25/+120	40	H
EWADH10T-X5B2	22	42,2	400V-3ph-50Hz	16	IP 55	F	-25/+120	40	H
EWADH11T-X5B2	22	42,2	400V-3ph-50Hz	16	IP 55	F	-25/+120	40	I
EWADC13T-X5B2	22	42,2	400V-3ph-50Hz	16	IP 55	F	-25/+120	40	J
EWADH13T-X5B2	22	38	400V-3ph-50Hz	16	IP 55	F	-25/+120	40	K
EWADC14T-X5B2	22	38	400V-3ph-50Hz	16	IP 55	F	-25/+120	40	K

Note: to calculate the total electrical data of the base unit selected with hydronic kit, the electrical data of the pump must be added to the electrical data of the base unit. Electrical data are subject to modification without notice. Please refer to unit nameplate.

Double pump low lift

EWAD T B S/X-S/L/R 300-700 kW (SILVER & GOLD series) – Available static pressure

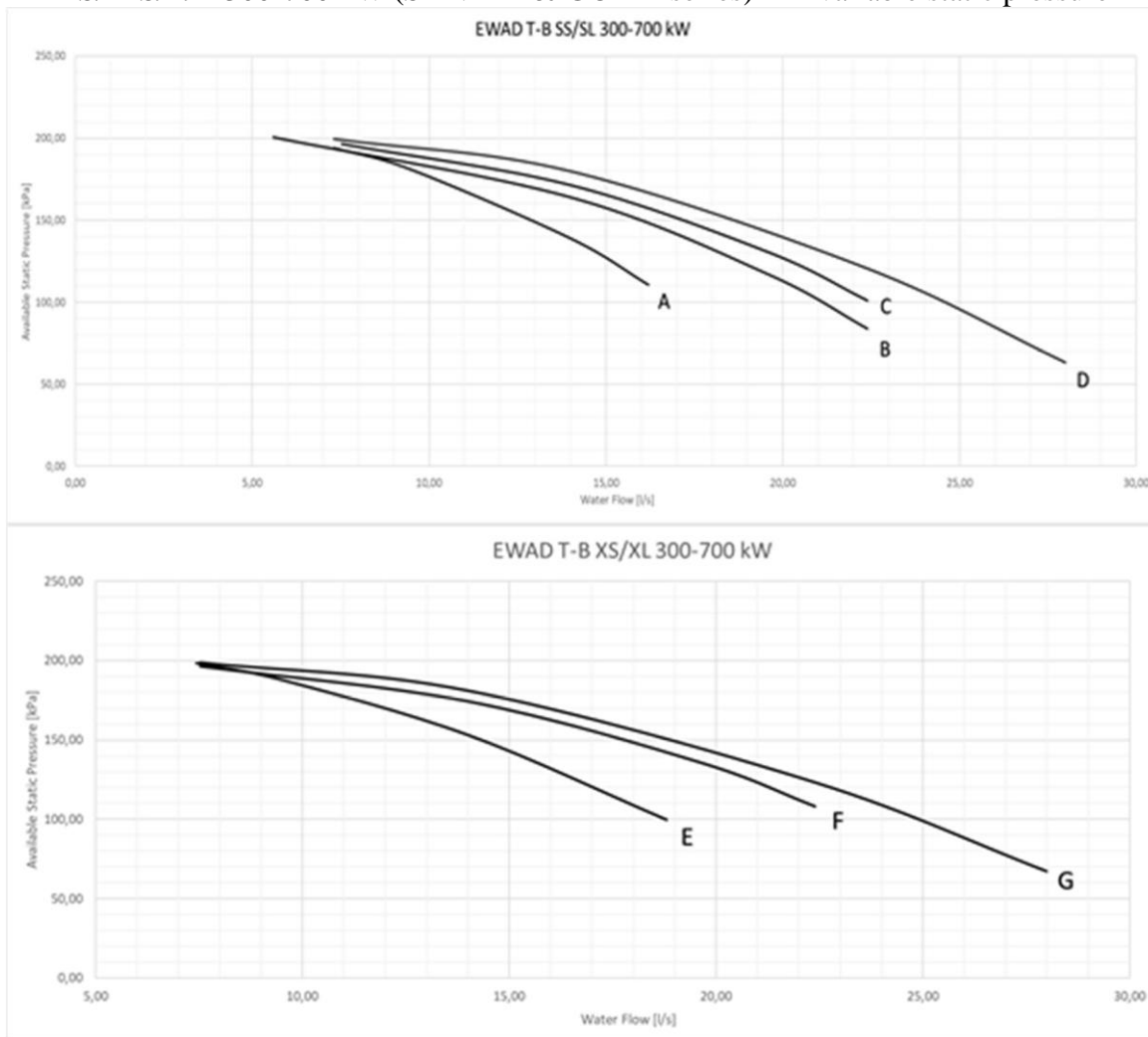

Model		Pump Motor Power [kW]	Pump Motor Current [A]	Power supply	PN	Motor protection	Insulation class	Working temperature [°C]	Max ambient temperatures [°C]	Ref. Curve
EWAD290T-SSB2	EWAD290T-SLB2	4	7,7	400V-3ph-50Hz	16	IP55	F	-25/+120	40	A
EWAD330T-SSB2	EWAD330T-SLB2	4	7,7	400V-3ph-50Hz	16	IP55	F	-25/+120	40	A
EWAD370T-SSB2	EWAD370T-SLB2	5,5	10,5	400V-3ph-50Hz	16	IP55	F	-25/+120	40	B
EWAD400T-SSB2	EWAD400T-SLB2	5,5	10,5	400V-3ph-50Hz	16	IP55	F	-25/+120	40	B
EWAD430T-SSB2	EWAD430T-SLB2	5,5	10,5	400V-3ph-50Hz	16	IP55	F	-25/+120	40	C
EWAD510T-SSB2	EWAD510T-SLB2	5,5	10,5	400V-3ph-50Hz	16	IP55	F	-25/+120	40	C
EWAD520T-SSB2	EWAD520T-SLB2	5,5	10,5	400V-3ph-50Hz	16	IP55	F	25/+120	40	D
EWAD580T-SSB2	EWAD580T-SLB2	ND	ND	ND	ND	ND	ND	ND	ND	ND
EWAD350T-XSB2	EWAD350T-XLB2	4	7,7	400V-3ph-50Hz	16	IP55	F	-25/+120	40	E
EWAD380T-XSB2	EWAD380T-XLB2	5,5	10,5	400V-3ph-50Hz	16	IP55	F	-25/+120	40	F
EWAD400T-XSB2	EWAD400T-XLB2	5,5	10,5	400V-3ph-50Hz	16	IP55	F	-25/+120	40	F
EWAD420T-XSB2	EWAD420T-XLB2	5,5	10,5	400V-3ph-50Hz	16	IP55	F	-25/+120	40	G
EWAD440T-XSB2	EWAD440T-XLB2	5,5	10,5	400V-3ph-50Hz	16	IP55	F	-25/+120	40	G
EWAD490T-XSB2	EWAD490T-XLB2	5,5	10,5	400V-3ph-50Hz	16	IP55	F	-25/+120	40	F
EWAD540T-XSB2	EWAD540T-XLB2	ND	ND	ND	ND	ND	ND	ND	ND	ND
EWAD570T-XSB2	EWAD570T-XLB2	ND	ND	ND	ND	ND	ND	ND	ND	ND

Note: to calculate the total electrical data of the base unit selected with hydronic kit, the electrical data of the pump must be added to the electrical data of the base unit. Electrical data are subject to modification without notice. Please refer to unit nameplate.

Double pump low lift

EWAD T B S/X-S/L/R 700-1400 kW (SILVER & GOLD series) – Available static pressure

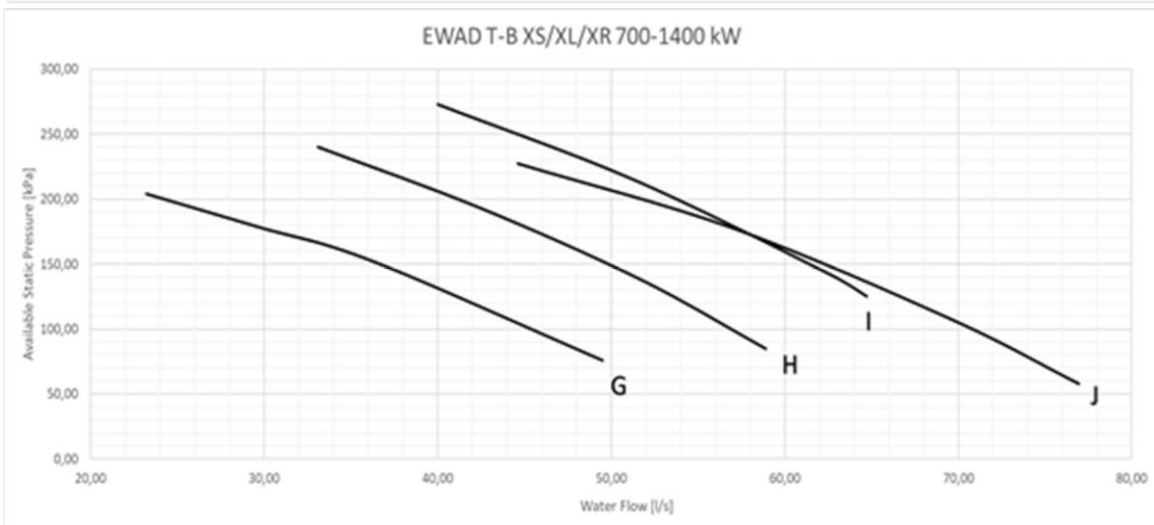
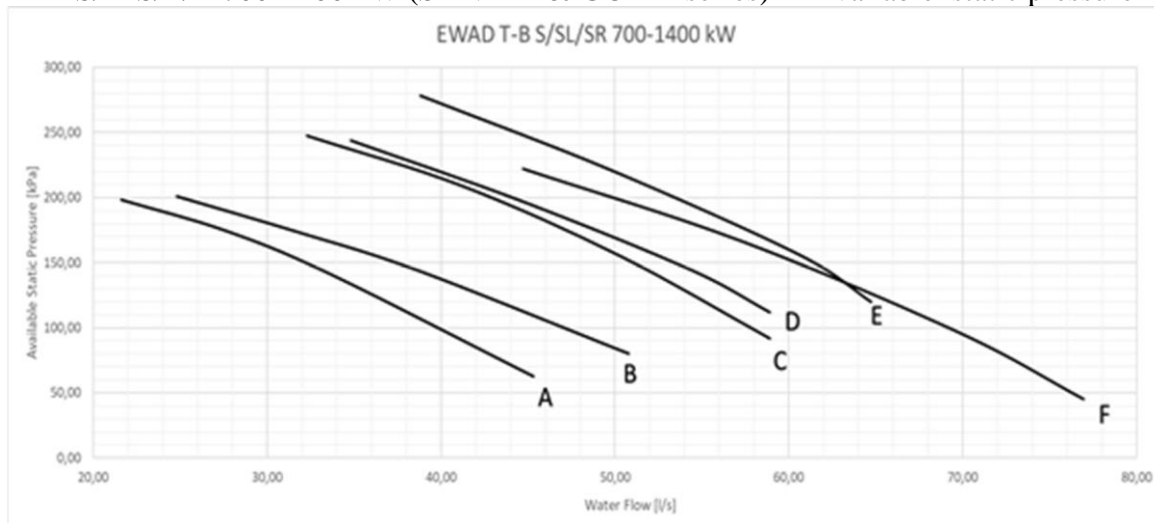

Model			Pump Motor Power [kW]	Pump Motor Current [A]	Power supply	PN	Motor protection	Insulation class	Working temperature [°C]	Max ambient temperatures [°C]	Ref. Curve
EWAD700T-SSB2	EWAD700T-SLB2	EWAD700T-SRB2	11	20,2	400V-3ph-50Hz	16	IP55	F	-25/+120		40 A
EWAD800T-SSB2	EWAD800T-SLB2	EWAD800T-SRB2	11	20,2	400V-3ph-50Hz	16	IP55	F	-25/+120		40 B
EWAD940T-SSB2	EWAD940T-SLB2	EWAD940T-SRB2	15	26,6	400V-3ph-50Hz	16	IP55	F	-25/+120		40 B
EWADC10T-S5B2	EWADC10T-SLB2	EWADC10T-SRB2	15	26,6	400V-3ph-50Hz	16	IP55	F	-25/+120		40 C
EWADH10T-SSB2	EWADH10T-SLB2	EWADH10T-SRB2	15	26,6	400V-3ph-50Hz	16	IP55	F	-25/+120		40 C
EWADC11T-S5B2	EWADC11T-SLB2	EWADC11T-SRB2	15	26,6	400V-3ph-50Hz	16	IP55	F	-25/+120		40 D
EWADH12T-SSB2	EWADH12T-SLB2	EWADH12T-SRB2	18,5	32,7	400V-3ph-50Hz	16	IP55	F	-25/+120		40 E
EWADH13T-SSB2	EWADH13T-SLB2	EWADH13T-SRB2	18,5	31,8	400V-3ph-50Hz	16	IP55	F	-25/+120		40 F
EWADH14T-SSB2	EWADH14T-SLB2	EWADH14T-SRB2	18,5	31,8	400V-3ph-50Hz	16	IP55	F	-25/+120		40 F
EWAD730T-X5B2	EWAD730T-XLB2	EWAD730T-XRB2	11	20,2	400V-3ph-50Hz	16	IP55	F	-25/+120		40 G
EWAD820T-X5B2	EWAD820T-XLB2	EWAD820T-XRB2	11	20,2	400V-3ph-50Hz	16	IP55	F	-25/+120		40 G
EWAD950T-X5B2	EWAD950T-XLB2	EWAD950T-XRB2	11	20,2	400V-3ph-50Hz	16	IP55	F	-25/+120		40 G
EWADC10T-X5B2	EWADC10T-XLB2	EWADC10T-XRB2	15	26,6	400V-3ph-50Hz	16	IP55	F	-25/+120		40 H
EWADH10T-X5B2	EWADH10T-XLB2	EWADH10T-XRB2	15	26,6	400V-3ph-50Hz	16	IP55	F	-25/+120		40 H
EWADH11T-X5B2	EWADH11T-XLB2	EWADH11T-XRB2	15	26,6	400V-3ph-50Hz	16	IP55	F	-25/+120		40 H
EWADC13T-X5B2	EWADC13T-XLB2	EWADC13T-XRB2	18,5	32,7	400V-3ph-50Hz	16	IP55	F	-25/+120		40 I
EWADH13T-X5B2	EWADH13T-XLB2	EWADH13T-XRB2	18,5	31,8	400V-3ph-50Hz	16	IP55	F	-25/+120		40 J
EWADC14T-X5B2	EWADC14T-XLB2	EWADC14T-XRB2	18,5	31,8	400V-3ph-50Hz	16	IP55	F	-25/+120		40 J

Note: to calculate the total electrical data of the base unit selected with hydronic kit, the electrical data of the pump must be added to the electrical data of the base unit. Electrical data are subject to modification without notice. Please refer to unit nameplate.

Double pump high lift

EWAD T B S/X-S/L/R 300-700 kW (SILVER & GOLD series) – Available static pressure

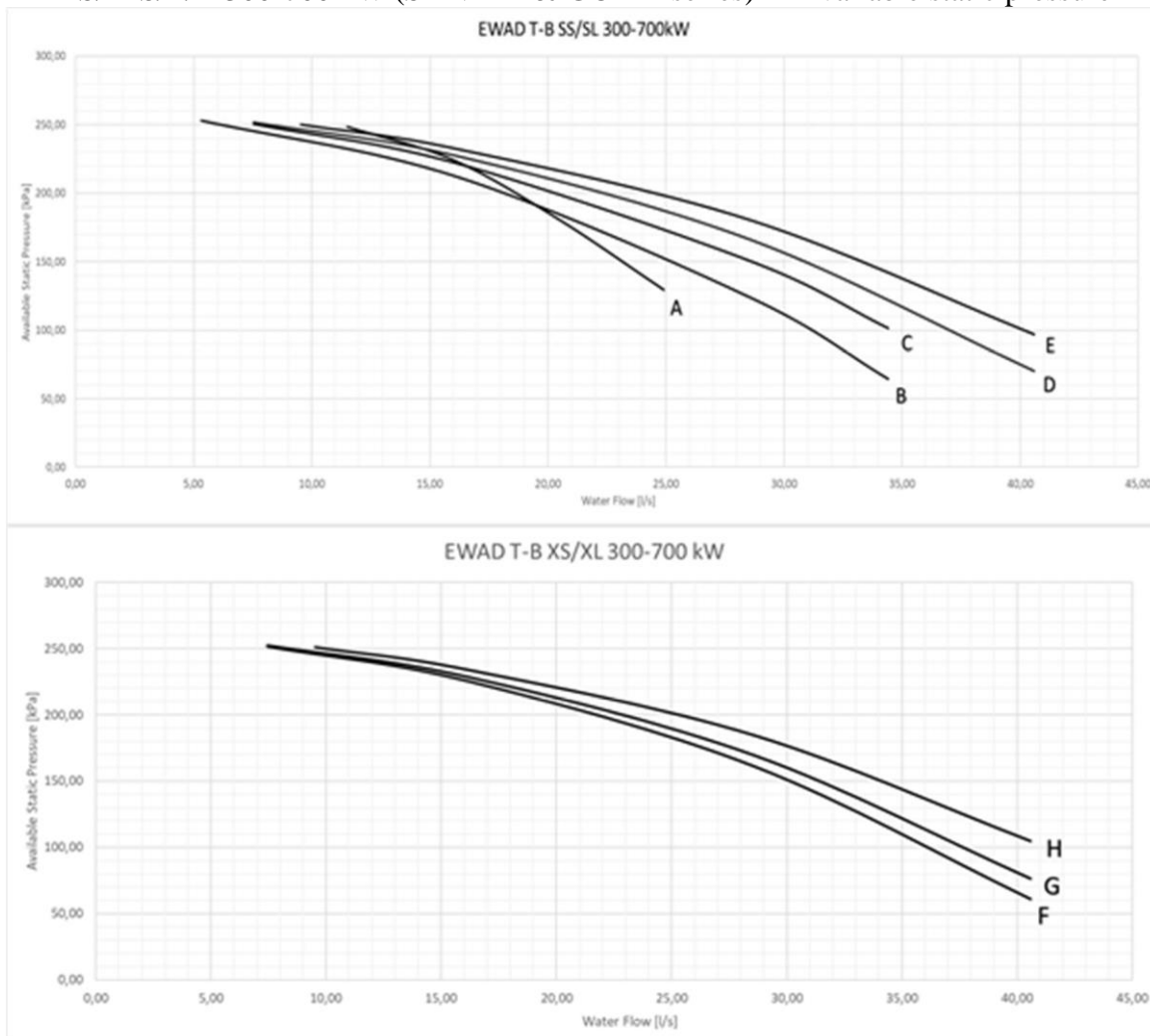

Model		Pump Motor Power [kW]	Pump Motor Current [A]	Power supply	PN	Motor protection	Insulation class	Working temperature °[C]	Max ambient temperatures [C°]	Ref. Curve
EWAD290T-SSB2	EWAD290T-SLB2	7,5	14,1	400V-3ph-50Hz	16	IP55	F	-25/+120	40	A
EWAD330T-SSB2	EWAD330T-SLB2	7,5	14,1	400V-3ph-50Hz	16	IP55	F	-25/+120	40	A
EWAD370T-SSB2	EWAD370T-SLB2	11	20,2	400V-3ph-50Hz	16	IP55	F	-25/+120	40	B
EWAD400T-SSB2	EWAD400T-SLB2	11	20,2	400V-3ph-50Hz	16	IP55	F	-25/+120	40	B
EWAD430T-SSB2	EWAD430T-SLB2	11	20,2	400V-3ph-50Hz	16	IP55	F	-25/+120	40	C
EWAD510T-SSB2	EWAD510T-SLB2	11	20,2	400V-3ph-50Hz	16	IP55	F	-25/+120	40	E
EWAD520T-SSB2	EWAD520T-SLB2	11	20,2	400V-3ph-50Hz	16	IP55	F	-25/+120	40	D
EWAD580T-SSB2	EWAD580T-SLB2	11	20,2	400V-3ph-50Hz	16	IP55	F	-25/+120	40	C
EWAD350T-XSB2	EWAD350T-XLB2	11	20,2	400V-3ph-50Hz	16	IP55	F	-25/+120	40	F
EWAD380T-XSB2	EWAD380T-XLB2	11	20,2	400V-3ph-50Hz	16	IP55	F	-25/+120	40	G
EWAD400T-XSB2	EWAD400T-XLB2	11	20,2	400V-3ph-50Hz	16	IP55	F	-25/+120	40	F
EWAD420T-XSB2	EWAD420T-XLB2	11	20,2	400V-3ph-50Hz	16	IP55	F	-25/+120	40	G
EWAD440T-XSB2	EWAD440T-XLB2	11	20,2	400V-3ph-50Hz	16	IP55	F	-25/+120	40	H
EWAD490T-XSB2	EWAD490T-XLB2	11	20,2	400V-3ph-50Hz	16	IP55	F	-25/+120	40	G
EWAD540T-XSB2	EWAD540T-XLB2	11	20,2	400V-3ph-50Hz	16	IP55	F	-25/+120	40	H
EWAD570T-XSB2	EWAD570T-XLB2	11	20,2	400V-3ph-50Hz	16	IP55	F	-25/+120	40	H

Note: to calculate the total electrical data of the base unit selected with hydronic kit, the electrical data of the pump must be added to the electrical data of the base unit. Electrical data are subject to modification without notice. Please refer to unit nameplate.

Double pump high lift

EWAD T B S/X-S/L/R 700-1400 kW (SILVER & GOLD series) – Available static pressure

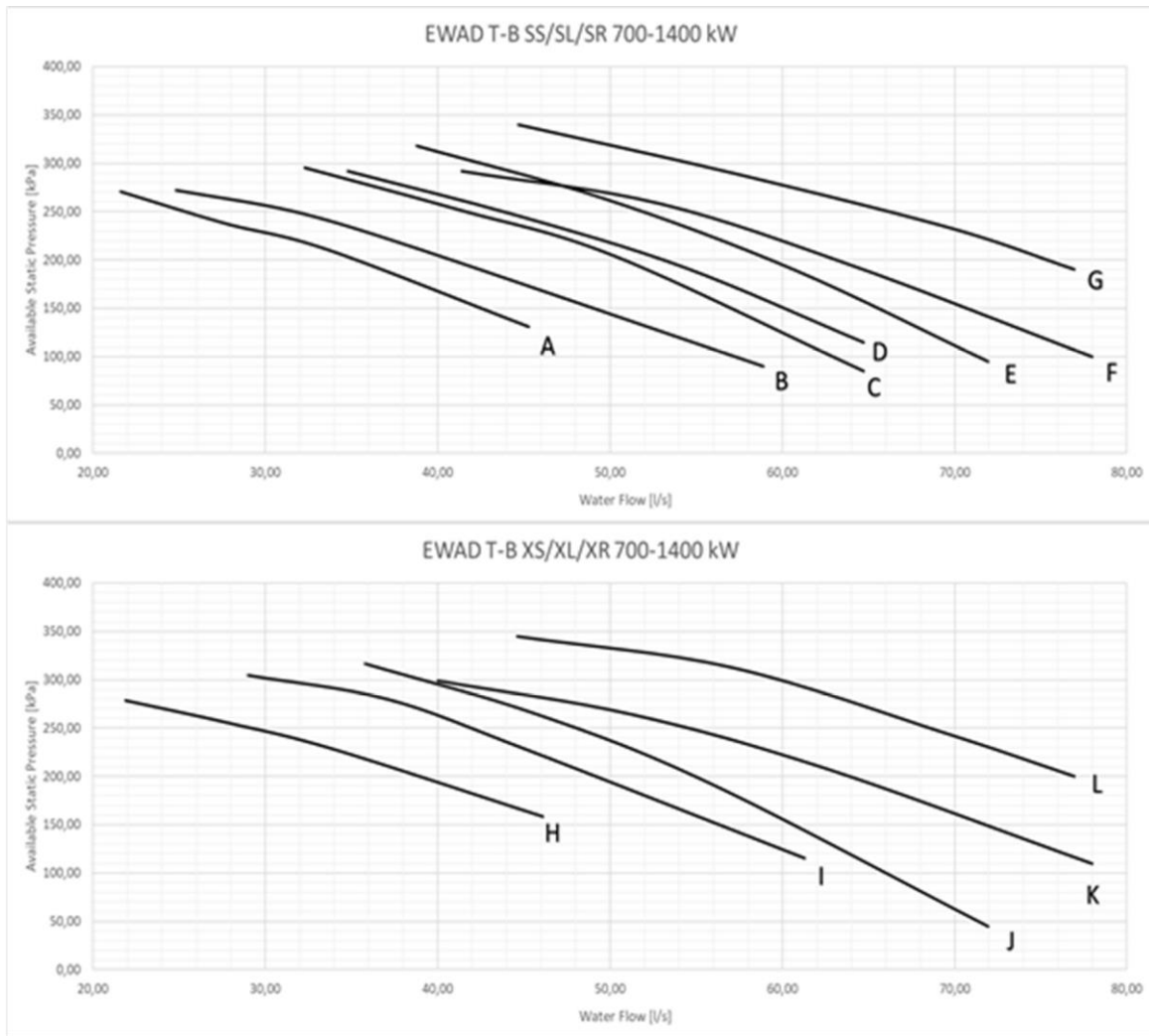

Model			Pump Motor Power [kW]	Pump Motor Current [A]	Power supply	PN	Motor protection	Insulation class	Working temperature °[C]	Max ambient temperatures [C°]	Ref. Curve
EWAD700T-SSB2	EWAD700T-SLB2	EWAD700T-SRB2	15	26,6	400V-3ph-50Hz	16	IP55	F	-25/+120	40	A
EWAD800T-SSB2	EWAD800T-SLB2	EWAD800T-SRB2	15	26,6	400V-3ph-50Hz	16	IP55	F	-25/+120	40	B
EWAD940T-SSB2	EWAD940T-SLB2	EWAD940T-SRB2	15	26,6	400V-3ph-50Hz	16	IP55	F	-25/+120	40	B
EWADC10T-SSB2	EWADC10T-SLB2	EWADC10T-SRB2	18,5	32,7	400V-3ph-50Hz	16	IP55	F	-25/+120	40	C
EWADH10T-SSB2	EWADH10T-SLB2	EWADH10T-SRB2	18,5	32,7	400V-3ph-50Hz	16	IP55	F	-25/+120	40	C
EWADC11T-SSB2	EWADC11T-SLB2	EWADC11T-SRB2	18,5	32,7	400V-3ph-50Hz	16	IP55	F	-25/+120	40	D
EWADH12T-SSB2	EWADH12T-SLB2	EWADH12T-SRB2	22	42,2	400V-3ph-50Hz	16	IP55	F	-25/+120	40	E
EWADH13T-SSB2	EWADH13T-SLB2	EWADH13T-SRB2	22	38	400V-3ph-50Hz	16	IP55	F	-25/+120	40	F
EWADH14T-SSB2	EWADH14T-SLB2	EWADH14T-SRB2	30	53	400V-3ph-50Hz	16	IP55	F	-25/+120	40	G
EWAD730T-XSB2	EWAD730T-XLB2	EWAD730T-XRB2	15	26,6	400V-3ph-50Hz	16	IP55	F	-25/+120	40	H
EWAD820T-XSB2	EWAD820T-XLB2	EWAD820T-XRB2	15	26,6	400V-3ph-50Hz	16	IP55	F	-25/+120	40	H
EWAD950T-XSB2	EWAD950T-XLB2	EWAD950T-XRB2	18,5	32,7	400V-3ph-50Hz	16	IP55	F	-25/+120	40	I
EWADC10T-XSB2	EWADC10T-XLB2	EWADC10T-XRB2	18,5	32,7	400V-3ph-50Hz	16	IP55	F	-25/+120	40	I
EWADH10T-XSB2	EWADH10T-XLB2	EWADH10T-XRB2	22	42,2	400V-3ph-50Hz	16	IP55	F	-25/+120	40	J
EWADH11T-XSB2	EWADH11T-XLB2	EWADH11T-XRB2	22	42,2	400V-3ph-50Hz	16	IP55	F	-25/+120	40	J
EWADC13T-XSB2	EWADC13T-XLB2	EWADC13T-XRB2	22	38	400V-3ph-50Hz	16	IP55	F	-25/+120	40	K
EWADH13T-XSB2	EWADH13T-XLB2	EWADH13T-XRB2	22	38	400V-3ph-50Hz	16	IP55	F	-25/+120	40	K
EWADC14T-XSB2	EWADC14T-XLB2	EWADC14T-XRB2	30	53	400V-3ph-50Hz	16	IP55	F	-25/+120	40	L

Note: to calculate the total electrical data of the base unit selected with hydronic kit, the electrical data of the pump must be added to the electrical data of the base unit. Electrical data are subject to modification without notice. Please refer to unit nameplate.

Hydraulic scheme

Dual circuit unit without hydronic kit

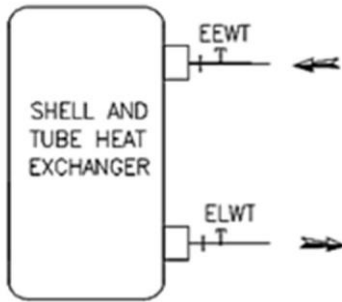

EEWT	EVAPOR. ENTERING WATER TEMPERATURE PROBE	EEWT	EVAPOR. LEAVING WATER TEMPERATURE PROBE
------	--	------	---

Note: drain plug and threaded fitting are on the shell and tube exchanger

Dual circuit unit with dual pump low/high lift

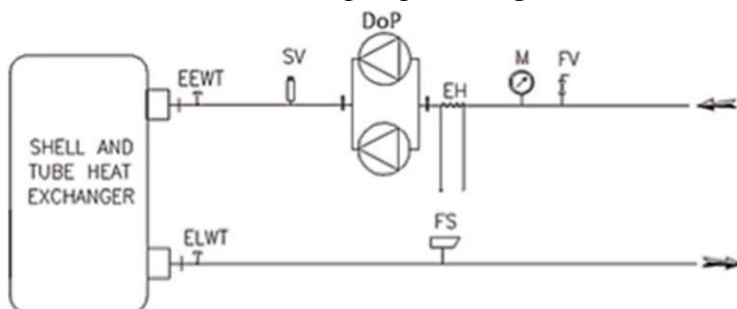

FV	FILLING VALVE	SV	SAFETY VALVE
M	PRESSURE GAUGE	EEWT	EVAPOR. ENTERING WATER TEMPERATURE PROBE
EH	ELECTRIC HEATER/ THERMOSTAT	EEWT	EVAPOR. LEAVING WATER TEMPERATURE PROBE
DoP	IN LINE DOUBLE PUMP	FS	FLOW SWITCH *

*Flow switch available as option (opt. code 58) safety valve set at 10 bar. Note: drain plug and threaded fitting are on the shell and tube exchanger.

Water piping

The water system must have:

1. Anti-vibration joint in order to reduce transmission of vibrations to the structures.
2. Isolating valves to isolate the unit from the water system during maintenance.
3. Flow switch.
4. Manual or automatic air venting device at the system's highest point.; drain device at the system's lowest point.
5. A suitable device that can maintain the water system under pressure (expansion tank, etc.).
6. Water temperature and pressure indicators to assist the operator during service and maintenance.
7. A filter or device that can remove particles from the fluid. The installation of the filter is mandatory. The use of a filter extends the life of the evaporator and pump and helps to keep the water system in a better condition. The water filter must be installed as close as possible to the chiller. If the water filter is installed in another part of the water system, the installer has to guarantee the cleaning of the water pipes between the water filter and the evaporator. The water used for filling the water circuit must be clean and suitably treated.
8. Precautions should be provided to protect the unit against freezing.
9. The heat recovery device must be emptied of water during the winter season, unless an ethylene glycol mixture in appropriate percentage is added to the water circuit.
10. If case of unit substitution, the entire water system must be emptied and cleaned before the new unit is installed. Regular tests and proper chemical treatment of water are recommended after starting up the new unit.

11. In the event that glycol is added to the water system as anti-freeze protection, pay attention to the fact that suction pressure will be lower, the unit's performance will be lower and water pressure drops will be greater. All unit-protection systems, such as anti-freeze, and low-pressure protection will need to be readjusted.

12. Before insulating water piping, check that there are no leaks.

DUAL CIRCUIT -B2

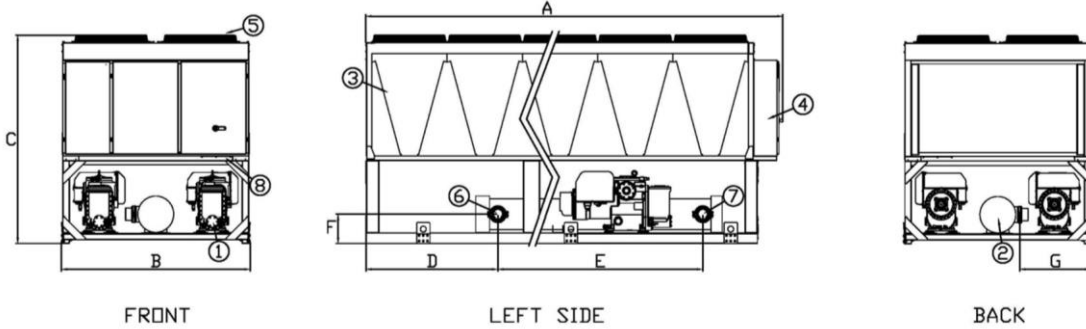

LEGEND

- 1. COMPRESSOR
- 2. EVAPORATOR
- 3. CONDENSER COIL
- 4. ELECTRICAL PANEL
- 5. FAN
- 6. EVAPORATOR WATER INLET
- 7. EVAPORATOR WATER OUTLET
- 8. SLOT FOR POWER AND CONTROL PANEL CONNCTION

note:

the above drawings are not contractually binding. For the design of installation refer to the dedicated dimensional drawing available from the factory on request. The data are subject to change without notice.

MODEL	A	B	C	D	E	F	G
EWAD290T-SS B2	3230	2258	2540				
EWAD330T-SS B2	3230	2258	2540				
EWAD370T-SS B2	4130	2258	2540				
EWAD400T-SS B2	4130	2258	2540				
EWAD430T-SS B2	4130	2258	2540				
EWAD510T-SS B2	4130	2258	2540				
EWAD520T-SS B2	5030	2258	2540				
EWAD580T-SS B2	5030	2258	2540				
EWAD700T-SS B2	5976	2282	2537	394	2412	386	809
EWAD800T-SS B2	5976	2282	2537	394	2412	386	809
EWAD940T-SS B2	6876	2282	2537	377	2962	376	809
EWADC10T-SS B2	6876	2282	2537	377	2962	376	809
EWADC11T-SS B2	7776	2282	2537	1087	2910	471	758
EWADH10T-SS B2	6876	2282	2537	402	2910	471	758
EWADH12T-SS B2	7776	2282	2537	1087	2910	471	758
EWADH13T-SS B2	8676	2282	2537	1987	2910	471	758
EWADH14T-SS B2	9576	2282	2537	2887	2910	471	758
EWADH15T-SS B3	10509	2282	2537				
EWADH16T-SS B3	11409	2282	2537				
EWADC17T-SS B3	11409	2282	2537				
EWADH18T-SS B3	11409	2282	2537				
EWADC19T-SS B3	12309	2282	2537				
EWADC20T-SS B3	13209	2282	2537				
EWADC21T-SS B3	14109	2282	2537				

DUAL CIRCUIT -B2

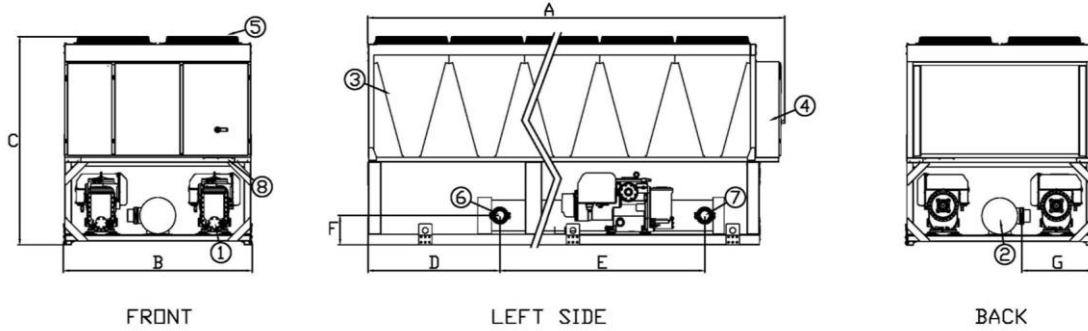

LEGEND

- 1. COMPRESSOR
- 2. EVAPORATOR
- 3. CONDENSER COIL
- 4. ELECTRICAL PANEL
- 5. FAN
- 6. EVAPORATOR WATER INLET
- 7. EVAPORATOR WATER OUTLET
- 8. SLOT FOR POWER AND CONTROL PANEL CONNCTION

note:

the above drawings are not contractually binding. For the design of installation refer to the dedicated dimensional drawing available from the factory on request. The data are subject to change without notice.

MODEL	A	B	C	D	E	F	G
EWAD290T-SL B2	3230	2258	2540				
EWAD330T-SL B2	3230	2258	2540				
EWAD370T-SL B2	4130	2258	2540				
EWAD400T-SL B2	4130	2258	2540				
EWAD430T-SL B2	4130	2258	2540				
EWAD510T-SL B2	4130	2258	2540				
EWAD520T-SL B2	5030	2258	2540				
EWAD580T-SL B2	5030	2258	2540				
EWAD700T-SL B2	5976	2282	2537	394	2412	386	809
EWAD800T-SL B2	5976	2282	2537	394	2412	386	809
EWAD940T-SL B2	6876	2282	2537	377	2962	376	809
EWADC10T-SL B2	6876	2282	2537	377	2962	376	809
EWADC11T-SL B2	7776	2282	2537	1087	2910	471	758
EWADH10T-SL B2	6876	2282	2537	402	2910	471	758
EWADH12T-SL B2	7776	2282	2537	1087	2910	471	758
EWADH13T-SL B2	8676	2282	2537	1987	2910	471	758
EWADH14T-SL B2	9576	2282	2537	2887	2910	471	758
EWADH15T-SL B3	10509	2282	2537				
EWADH16T-SL B3	11409	2282	2537				
EWADC17T-SL B3	11409	2282	2537				
EWADH18T-SL B3	11409	2282	2537				
EWADC19T-SL B3	12309	2282	2537				
EWADC20T-SL B3	13209	2282	2537				
EWADC21T-SL B3	14109	2282	2537				

DUAL CIRCUIT -B2

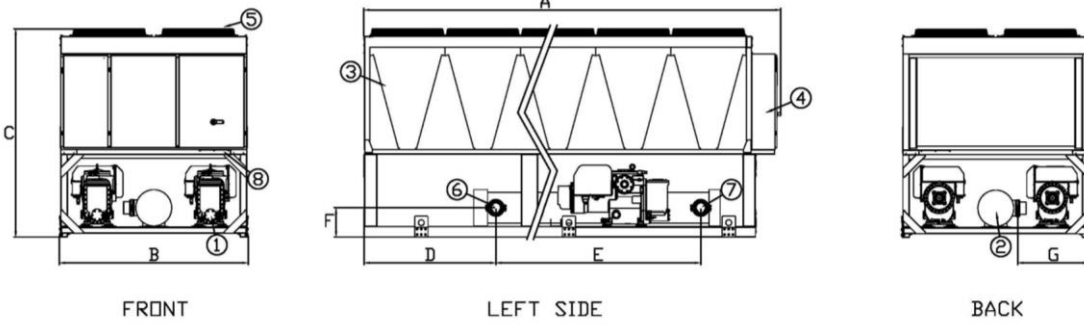

LEGEND

- 1. COMPRESSOR
- 2. EVAPORATOR
- 3. CONDENSER COIL
- 4. ELECTRICAL PANEL
- 5. FAN
- 6. EVAPORATOR WATER INLET
- 7. EVAPORATOR WATER OUTLET
- 8. SLOT FOR POWER AND CONTROL PANEL CONNCTION

note:

the above drawings are not contractually binding. For the design of installation refer to the dedicated dimensional drawing available from the factory on request. The data are subject to change without notice.

MODEL	A	B	C	D	E	F	G
EWAD700T-SR B2	5976	2282	2537	394	2412	386	809
EWAD800T-SR B2	5976	2282	2537	394	2412	386	809
EWAD940T-SR B2	6876	2282	2537	377	2962	376	809
EWADC10T-SR B2	6876	2282	2537	377	2962	376	809
EWADC11T-SR B2	7776	2282	2537	1087	2910	471	758
EWADH10T-SR B2	6876	2282	2537	402	2910	471	758
EWADH12T-SR B2	7776	2282	2537	1087	2910	471	758
EWADH13T-SR B2	8676	2282	2537	1987	2910	471	758
EWADH14T-SR B2	9576	2282	2537	2887	2910	471	758
EWADH15T-SR B3	10509	2282	2537				
EWADH16T-SR B3	11409	2282	2537				
EWADC17T-SR B3	11409	2282	2537				
EWADH18T-SR B3	11409	2282	2537				
EWADC19T-SR B3	12309	2282	2537				
EWADC20T-SR B3	13209	2282	2537				
EWADC21T-SR B3	14109	2282	2537				

DUAL CIRCUIT -B2

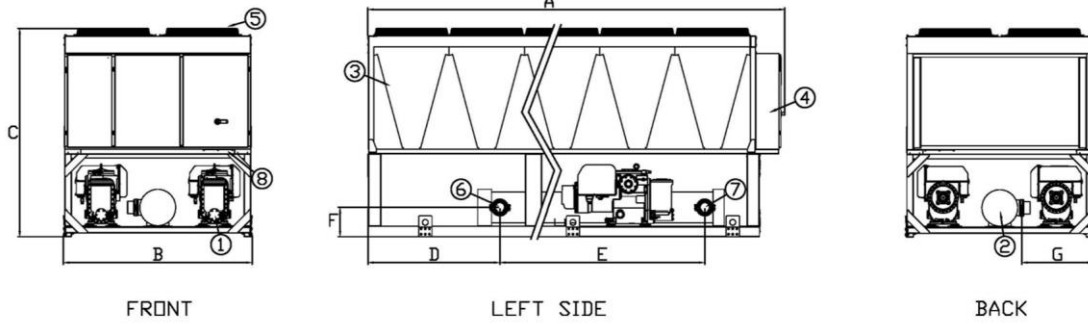

LEGEND

- 1. COMPRESSOR
- 2. EVAPORATOR
- 3. CONDENSER COIL
- 4. ELECTRICAL PANEL
- 5. FAN
- 6. EVAPORATOR WATER INLET
- 7. EVAPORATOR WATER OUTLET
- 8. SLOT FOR POWER AND CONTROL PANEL CONNCTION

note:

the above drawings are not contractually binding. For the design of installation refer to the dedicated dimensional drawing available from the factory on request. The data are subject to change without notice.

MODEL	A	B	C	D	E	F	G
EWAD350T-XS B2	4130	2258	2540				
EWAD380T-XS B2	4130	2258	2540				
EWAD400T-XS B2	5030	2258	2540				
EWAD420T-XS B2	5030	2258	2540				
EWAD440T-XS B2	5030	2258	2540				
EWAD490T-XS B2	5030	2258	2540				
EWAD540T-XS B2	5878	2258	2540				
EWAD570T-XS B2	5878	2258	2540				
EWAD730T-XS B2	5976	2282	2537	394	2412	386	809
EWAD820T-XS B2	5976	2282	2537	394	2412	386	809
EWAD950T-XS B2	7776	2282	2537	1056	2962	376	809
EWADC10T-XS B2	7776	2282	2537	1056	2962	376	809
EWADC13T-XS B2	9576	2282	2537	2887	2910	471	758
EWADC14T-XS B2	10476	2282	2537	3787	2910	471	758
EWADH10T-XS B2	8676	2282	2537	1987	2910	471	758
EWADH11T-XS B2	9576	2282	2537	2887	2910	471	758
EWADH13T-XS B2	10476	2282	2537	3787	2910	471	758
EWADH15T-XS B3	11409	2282	2537				
EWADH16T-XS B3	12309	2282	2537				
EWADC17T-XS B3	13209	2282	2537				
EWADH18T-XS B3	14109	2282	2537				
EWADC19T-XS B3	14109	2282	2537				
EWADC20T-XS B3	14109	2282	2537				

DUAL CIRCUIT -B2

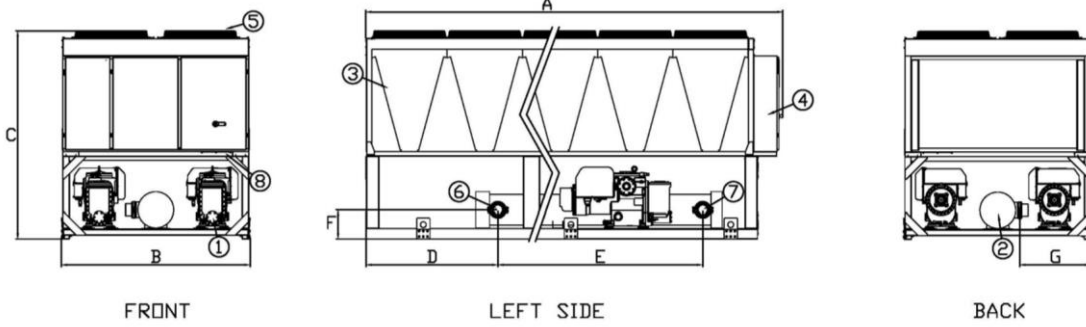

LEGEND

- 1. COMPRESSOR
- 2. EVAPORATOR
- 3. CONDENSER COIL
- 4. ELECTRICAL PANEL
- 5. FAN
- 6. EVAPORATOR WATER INLET
- 7. EVAPORATOR WATER OUTLET
- 8. SLOT FOR POWER AND CONTROL PANEL CONNCTION

note:

the above drawings are not contractually binding. For the design of installation refer to the dedicated dimensional drawing available from the factory on request. The data are subject to change without notice.

MODEL	A	B	C	D	E	F	G
EWAD350T-XL B2	4130	2258	2540				
EWAD380T-XL B2	4130	2258	2540				
EWAD400T-XL B2	5030	2258	2540				
EWAD420T-XL B2	5030	2258	2540				
EWAD440T-XL B2	5030	2258	2540				
EWAD490T-XL B2	5030	2258	2540				
EWAD540T-XL B2	5878	2258	2540				
EWAD570T-XL B2	5878	2258	2540				
EWAD730T-XL B2	5976	2282	2537	394	2412	386	809
EWAD820T-XL B2	5976	2282	2537	394	2412	386	809
EWAD950T-XL B2	7776	2282	2537	1056	2962	376	809
EWADC10T-XL B2	7776	2282	2537	1056	2962	376	809
EWADC13T-XL B2	9576	2282	2537	2887	2910	471	758
EWADC14T-XL B2	10476	2282	2537	3787	2910	471	758
EWADH10T-XL B2	8676	2282	2537	1987	2910	471	758
EWADH11T-XL B2	9576	2282	2537	2887	2910	471	758
EWADH13T-XL B2	10476	2282	2537	3787	2910	471	758
EWADH15T-XL B3	11409	2282	2537				
EWADH16T-XL B3	12309	2282	2537				
EWADC17T-XL B3	13209	2282	2537				
EWADH18T-XL B3	14109	2282	2537				
EWADC19T-XL B3	14109	2282	2537				
EWADC20T-XL B3	14109	2282	2537				

DUAL CIRCUIT -B2

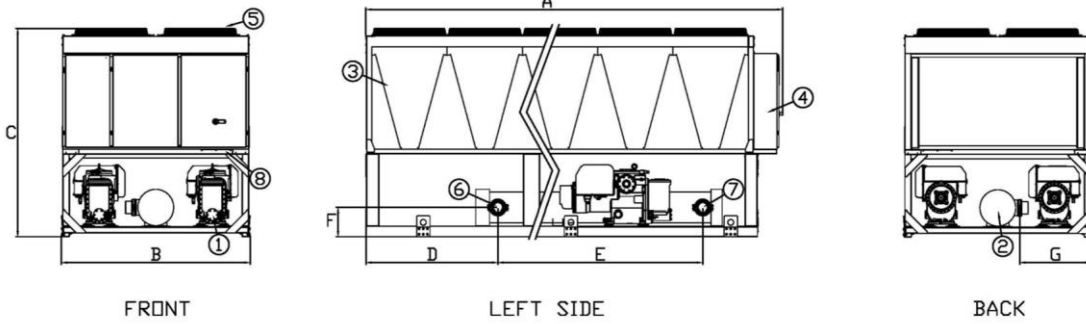

LEGEND

- 1. COMPRESSOR
- 2. EVAPORATOR
- 3. CONDENSER COIL
- 4. ELECTRICAL PANEL
- 5. FAN
- 6. EVAPORATOR WATER INLET
- 7. EVAPORATOR WATER OUTLET
- 8. SLOT FOR POWER AND CONTROL PANEL CONNCTION

note:

the above drawings are not contractually binding. For the design of installation refer to the dedicated dimensional drawing available from the factory on request. The data are subject to change without notice.

MODEL	A	B	C	D	E	F	G
EWAD730T-XR B2	5976	2282	2537	394	2412	386	809
EWAD820T-XR B2	5976	2282	2537	394	2412	386	809
EWAD950T-XR B2	7776	2282	2537	1056	2962	376	809
EWADC10T-XR B2	7776	2282	2537	1056	2962	376	809
EWADC13T-XR B2	9576	2282	2537	2887	2910	471	758
EWADC14T-XR B2	10476	2282	2537	3787	2910	471	758
EWADH10T-XR B2	8676	2282	2537	1987	2910	471	758
EWADH11T-XR B2	9576	2282	2537	2887	2910	471	758
EWADH13T-XR B2	10476	2282	2537	3787	2910	471	758
EWADH15T-XR B3	11409	2282	2537				
EWADH16T-XR B3	12309	2282	2537				
EWADC17T-XR B3	13209	2282	2537				
EWADH18T-XR B3	14109	2282	2537				
EWADC19T-XR B3	14109	2282	2537				
EWADC20T-XR B3	14109	2282	2537				

Warning Installation and maintenance of the unit must be performed only by qualified personnel who have knowledge with local codes and regulations, and experience with this type of equipment. Must be avoided the unit installation in places that could be considered dangerous for all the maintenance operations.

Handling Care should be taken to avoid rough handling or shock due to dropping the unit. Do not push or pull the unit from anything other than the base frame. Never allow the unit to fall during unloading or moving as this may result in serious damage. To lift the unit, rings are provided in the base frame of the unit. Spreader bar and cables should be arranged to prevent damage to cabinet.

Location The units are produced for outdoor installation on roofs, floors or below ground level on condition that the area is free from obstacles for the passage of the condenser air. The unit should be positioned on solid foundations and perfectly leveled; in the case of installation on roofs or floors, it may be advisable to arrange the use of suitable weight distribution beams. When the units are installed on the ground, a concrete base at least 250 mm wider and longer than the unit's footprint should be laid. Furthermore, this base should withstand the unit weight mentioned in the technical data table.

Space requirements The units are air-cooled, then it is important to respect the minimum distances which guarantee the best ventilation of the condenser coils. Limitations of space reducing the air flow could cause significant reductions in cooling capacity and an increase in electricity consumption. To determinate unit placement, careful consideration must be given to assure a sufficient air flow across the condenser heat transfer surface. Two conditions must be avoided to achieve the best performance: warm air recirculation and coil starvation. Both these conditions cause an increase of condensing pressures that results in reductions in unit efficiency and capacity. Moreover the unique microprocessor has the ability to calculate the operating environment of the air cooled chiller and the capacity to optimize its performance staying on-line during abnormal conditions. Each side of the unit must be accessible after installation for periodic service. The following pictures shows you minimum recommended clearance requirements.

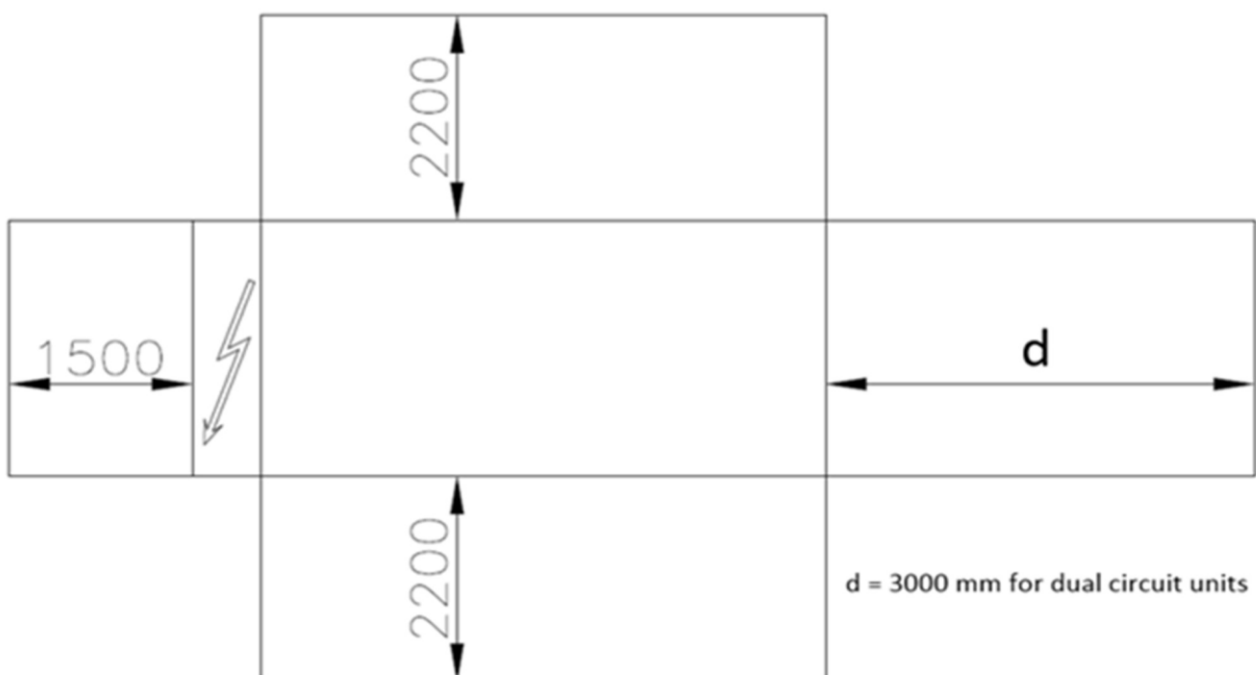

For single chiller installation in proximity of a wall the following indications are recommended:

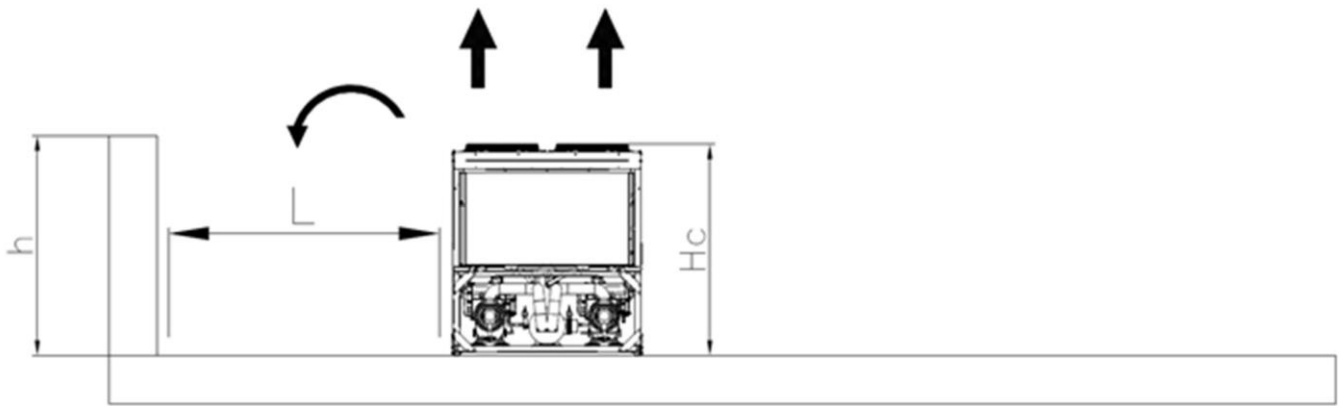

- if $h < H_c \rightarrow L$ must at least 3 m
- if $h \geq H_c$ or $L < 3$ m contact local Daikin representative to evaluate possible arrangements

In case of two chillers installed side by side in free filed, the minimum distance recommended between the chillers is indicated in the below picture

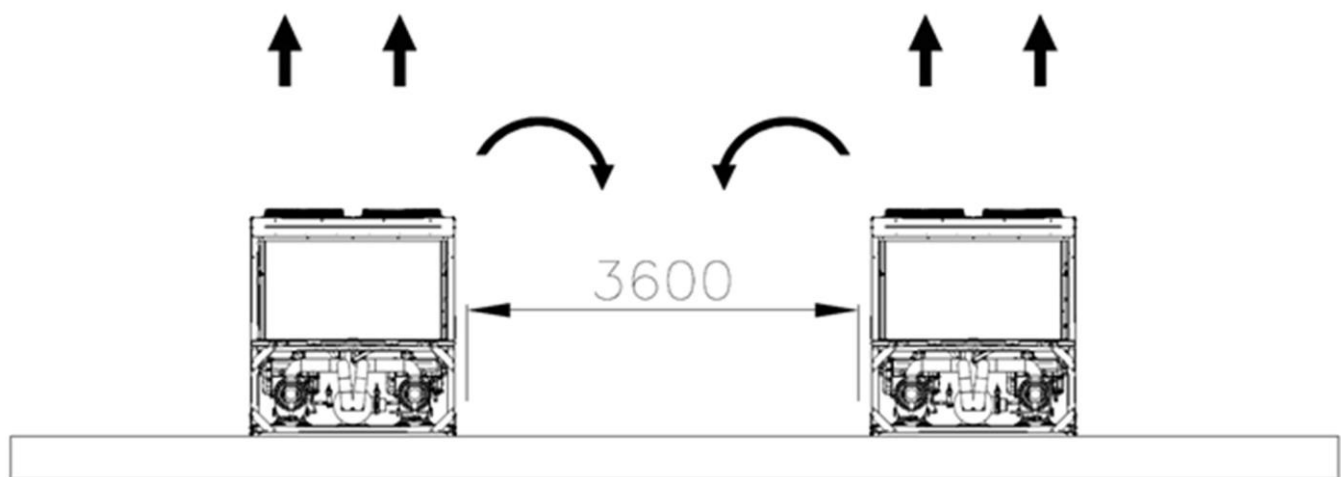

- In case of two chillers installed in a compound contact local Daikin representative to evaluate possible arrangements.
- For multiple chiller installation it is recommended to install the chillers in a single row as shown in the below picture

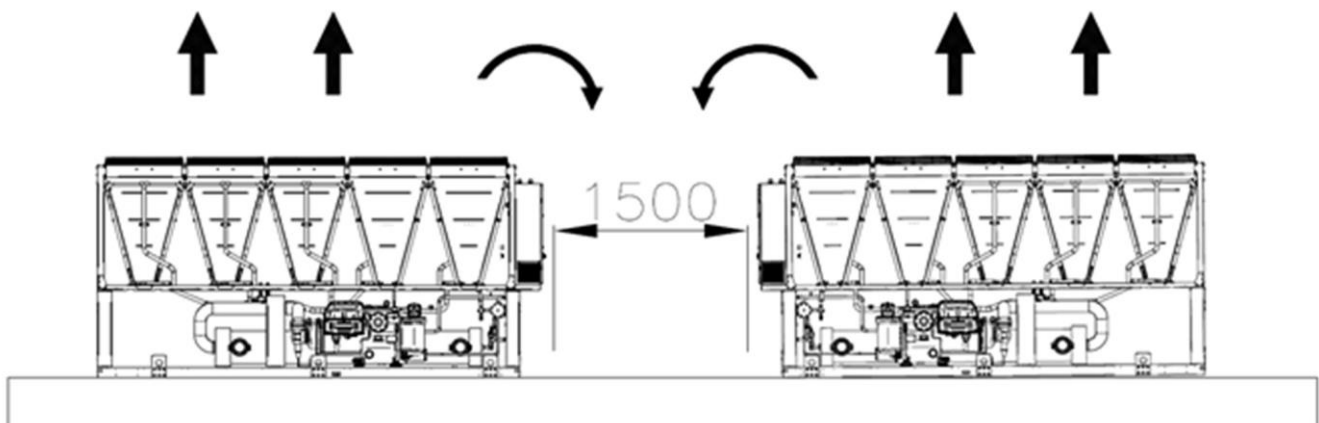

- For additional information refer to the Installation Manual.
- If the site does not allow this kind of installation contact Daikin representative to evaluate possible arrangements.

General The chiller will be designed and manufactured in accordance with the following European directives:

- Construction of pressure vessel 2014/68/EU
- Machinery Directive 2006/42/EC
- Low Voltage 2014/35/EU
- Electromagnetic Compatibility 2014/30/EU
- Electrical & Safety codes EN 60204 –1 / EN 60335-2-40
- Manufacturing Quality Standards UNI – UNI EN ISO 1400

To avoid any losses, the unit will be tested at full load in the factory (at the nominal working conditions and water temperatures). The chiller will be delivered to the job site completely assembled and charged with refrigerant and oil. The installation of the chiller must comply with the manufacturer’s instructions for rigging and handling equipment.

The unit will be able to start up and operate (as standard) at full load with:

- outside air temperature from °C to °C
- evaporator leaving fluid temperature between °C and °C

Refrigerant HFC 134a

Performance Chiller shall supply the following performances:

- Number of chiller(s) : unit(s)
- Cooling capacity for single chiller : kW
- Power input for single chiller in cooling mode : kW
- Heat exchanger entering water temperature in cooling mode : °C
- Heat exchanger leaving water temperature in cooling mode : °C
- Heat exchanger water flow : l/s
- Nominal outside working ambient temperature in cooling mode : °C
- Minimum full load efficiency (EER): (kW/kW)
- Minimum part load efficiency (ESEER): (kW/kW)

Operating voltage range should be 400V ±10%, 3ph, 50Hz, voltage unbalance maximum 3%, without neutral conductor and shall only have one power connection point.

Unit description Chiller shall include two independent refrigerant circuits, semi -hermetic type rotary single screw compressors, electronic expansion device (EEXV), direct expansion ‘shell & tube’ evaporator, air-cooled condenser section made with aluminum Microchannel technology, R-134a refrigerant, lubrication system, motor starting components, discharge line shut-off valve, control system and all components necessary for a safe and stable unit operation.

Sound level and vibrations Sound power level shall not exceeddB(A). The sound power levels must be rated in accordance to ISO 9614 (other types of rating cannot be used). Vibration on the base frame should not exceed 2 mm/s.

Dimensions Unit dimensions shall not exceed following indications:

- Unit length mm
- Unit width mm
- Unit height mm

Compressors The unit shall be equipped with:

- Semi -hermetic, single -screw type with one main helical rotor meshing with two diametrical opposed gate rotors. The gate rotor will be constructed of a carbon impregnated engineered composite material. The gate rotor supports will be constructed of cast iron. Electrical motor shall be 2-pole, semi -hermetic,

squirrel-cage induction type and cooled by suction gas.

- The compressor shall be provided with a built in, high efficiency, mesh type oil separator and oil filter.
- Refrigerant system differential pressure shall provide oil injection on all moving compressor parts to correctly lubricate them. Electrical oil pump lubricating system is not acceptable.
- The compressor's oil cooling must be realized, when necessary, by refrigerant liquid injection. External dedicated heat exchanger and additional piping to carry the oil from the compressor to heat exchanger and viceversa will be not accepted.
- The compressor shall be direct electrical driven, without gear transmission between the screw and the electrical motor.
- The compressor casing shall be provided with ports to realize economized refrigerant cycles.
- The unit shall be provided with two thermal protection realized by a thermistor for high temperature protection: one temperature sensor to protect electrical motor and another sensor to protect unit and lubricating oil from high discharge gas temperature.
- The compressor shall be equipped with an electric oil-crankcase heater.
- Compressor shall be fully field serviceable. Compressor that must be removed and returned to the factory for service shall be unacceptable. Cooling capacity control system The chiller will have a microprocessor for the control of the compressor capacity through inverter in order to continuously modulate the compressor's rotational speed.
- The unit capacity control shall be infinitely modulating between 100% and the minimum.
- The system shall control the unit based on the leaving evaporator water temperature that shall be controlled by PID (Proportional Integral Derivative) logic.

Evaporator

The units shall be equipped with a direct expansion shell & tube evaporator with copper tubes rolled into steel tube sheets. The evaporator shall be single-pass on both the refrigerant and water sides for pure counter-flow heat exchange and low refrigerant pressure drops.

- The external shell shall be linked with an electrical heater to prevent freezing down to -28°C ambient temperature, controlled by a thermostat and shall be insulated with flexible, closed cell polyurethane insulation material (20-mm thick).
- The evaporator will have 2 circuits, one for each compressor and shall be single refrigerant pass.
- The water connections shall be VICTAULIC type connections as standard to ensure quick mechanical disconnection between the unit and the hydronic network.
- The evaporator will be manufactured in accordance to PED approval.
- Flow switch on evaporator available as option (shipped loose).
- Water filter needs to be provided on the plant.

Condenser coil The condenser is made entirely of aluminum with flat tubes containing small channels. Full - depth louvered aluminum fins are inserted between the tubes maximizing the heat exchange. The Microchannel technology ensures the highest performance with the minimum surface for the exchanger. The quantity of refrigerant is also reduced compared to Cu/Al condenser. Special treatments ensure resistance to the corrosion by atmospheric agents extending the life time (available on request).

Condenser fans The condenser fans used in conjunction with the condenser coils, shall be propeller type with aluminum -magnesium alloy blades for higher efficiencies and lower sound. Each fan shall be protected by a fan guard.

- The air discharge shall be vertical and each fan must be coupled to the electrical motor, supplied as standard to IP54 and capable to work to ambient temperatures of - 20°C to + 65°C.
- The condenser fans shall have as a standard a thermally protection by internal thermal motor protection and protected by circuit breaker installed inside the electrical panel as a standard.

Refrigerant circuit The unit shall have two independent refrigerant circuits. The circuit shall include as standard: electronic expansion device piloted by unit's microprocessor control, compressor discharge shut-off valves, liquid line shut-off valve, economizer circuit, sight glass with moisture indicator, replaceable filter drier, charging valves, high pressure switch, high and low pressure transducers, oil pressure transducer and insulated suction line.

Low sound unit configurations (on request) The unit compressor shall be connected with unit's metal base frame by rubber antivibration supports to prevent the transmission of vibrations to all metal unit structure, in order to control the unit sound.

- The chiller shall be provided with an acoustical compressor enclosure. This enclosure shall be realized with a light, corrosion resisting aluminum structure and metal panels. The compressor sound -proof enclosure shall be internally fitted with flexible, multi -layer, high density materials.

Hydronic kit options (on request) The hydronic module shall be integrated in the chiller chassis without increasing its dimensions and includes the following elements: centrifugal pump with motor protected by a circuit breaker installed in control panel, water filling system with pressure gauge, safety valve, drain valve.

- The hydronic module shall be assembled and wired to the control panel.
- The water piping shall be protected against corrosion and freezing and insulated to prevent condensation.
- A choice of two pump types shall be available:
 - in-line single pump
 - in-line twin pumps.

Master/Slave the unit shall be able to operate in Master / Slave mode in order to be connected with other similar unit (up to 4). The master unit shall manage the slaves units connected in series on the hydraulic plant with the aim of optimize the running hours of each compressor and to balance running hours and the load between the units.

Electrical control panel Power and control shall be located in the main panel that will be manufactured to ensure protection against all weather conditions.

- The electrical panel shall be IP54 and (when opening the doors) internally protected against possible accidental contact with live parts.
- The main panel shall be fitted with a main switch interlocked door that shuts off power supply when opening.
- The power section will include compressors and fans protection devices, fans starters and control circuit power supply.

Controller The controller will be installed as standard and it will be used to modify unit set-points and check control parameters.

- A built -in display will shows chiller operating status plus temperatures and pressures of water, refrigerant and air, programmable values, set-points.
- A sophisticated software with predictive logic, will select the most energy efficient combination of compressors, EEXV and condenser fans to keep stable operating conditions to maximize chiller energy efficiency and reliability.
- The controller will be able to protect critical components based on external signals from its system (such as motor temperatures, refrigerant gas and oil pressures, correct phase sequence, pressure switches and evaporator). The input coming from the high pressure switch cuts all digital output from the controller in less than 50ms, this will be an additional security for the equipment.
- Fast program cycle (200ms) for a precise monitoring of the system.
- Floating point calculations supported for increased accuracy in P/T conversions.

Controller main features

Controller shall be guarantee following minimum functions:

- Management of the compressor stepless capacity and fans modulation.
- Chiller enabled to work in partial failure condition.
- Full routine operation at condition of:
 - high ambient temperature value
 - high thermal load
 - high evaporator entering water temperature (start -up)
- Display of evaporator entering/leaving water temperature.
- Display of Outdoor Ambient Temperature.
- Display of condensing -evaporating temperature and pressure, suction and discharge superheat for each circuit.
- Leaving water evaporator temperature regulation.
- Compressor and evaporator pumps hours counter.
- Display of Status Safety Devices.
- Number of starts and compressor working hours.
- Optimized management of compressor load.
- Fan management according to condensing pressure.
- Re-start in case of power failure (automatic / manual).
- Soft Load (optimized management of the compressor load during the start -up).
- Start at high evaporator water temperature.
- Return Reset (Set Point Reset based on return water temperature).
- OAT (Outside Ambient temperature) Reset.
- Set point Reset (optional).
- Application and system upgrade with commercial SD cards.
- Ethernet port for remote or local servicing using standard web browsers.
- Master / Slave (provided as standard)
- Two different sets of default parameters could be stored for easy restore.

High Level Communications

Interface (on request) The chiller shall be able to communicate to BMS (Building Management System) based on the most common protocols as:

- ModbusRTU
- LonWorks, now also based on the international 8040 Standard Chiller Profile and LonMark Technology
- BacNet BTP certified over IP