



## Operating Manual

**Air Handling Unit**  
Application Software name: Airstream  
D-EOMAH00001-16EN



## Index

<b>1. Air Handling Unit Safety Information</b> .....	4
<b>2. Introduction</b> .....	4
<b>3. User interface</b> .....	6
3.1 Controller POL687/638 Interfaces.....	6
3.2 External Human Machine Interfaces.....	7
3.2.1 6-Button LCD HMI (POL871) .....	7
3.2.2 Push & Roll key HMI (POL895).....	8
3.3 WEB-Human Machine Interface .....	10
3.4 Communication Modules .....	14
3.4.1 Modbus module installation.....	14
3.4.2 BACnet IP module installation .....	15
3.5 Basic Control System Diagnostic .....	15
<b>4. Control Functions</b> .....	17
4.1 Air Quality Control Function.....	18
4.2 Humidity Control Function .....	18
4.3 Summer/Winter mode changeover functions.....	19
<b>5. Main Menu screen</b> .....	20
<b>6. Control Source</b> .....	22
<b>7. Actual Mode</b> .....	23
<b>8. Unit State</b> .....	24
<b>9. Active Setpoint</b> .....	26
<b>10. Local Switch</b> .....	27
<b>11. Summer/Winter state</b> .....	28
<b>12. Setpoints</b> .....	30
<b>13. I/O Overview</b> .....	33
<b>14. Time Scheduler</b> .....	33
14.1 Day Scheduler .....	34
14.2 Calendar exception and Calendar fix off .....	35
<b>15. Status/Settings</b> .....	37
15.1 Temperature Control.....	39
15.2 Air Quality Control.....	39
15.3 Humidity Control .....	40

15.4	Fans Control.....	41
15.4.1	<i>Fast Heating/Cooling</i> .....	45
15.5	Dampers Control.....	46
15.6	Heat Recovery Control.....	46
15.7	Cooling Coil Control.....	47
15.8	Heating Coil Control.....	48
15.9	Pumps Control.....	49
15.10	ERQ Control.....	50
15.10.1	<i>ERQ Status</i> .....	50
15.10.2	<i>ERQ Settings</i> .....	51
15.11	Post-Heating Electrical Control.....	53
15.12	Pre-Heating Electrical Control.....	53
15.13	Pre-Heating Water Control.....	54
<b>16.</b>	<b>Commissioning</b> .....	<b>55</b>
16.1	Configuration Save & Load.....	56
16.2	Communication Modules Configuration.....	57
16.2.1	<i>Modbus</i> .....	57
16.2.2	<i>BACnet-IP</i> .....	58
16.3	Daylight saving time.....	60
<b>17.</b>	<b>Alarm handling</b> .....	<b>62</b>
17.1	Alarm restore.....	62
17.2	Alarm list.....	63
<b>18.</b>	<b>About Unit</b> .....	<b>71</b>
<b>Appendix A: Room Unit Module - POL822</b> .....		<b>73</b>
<b>Appendix B: iTM Installation &amp; Configuration</b> .....		<b>79</b>

## 1. Air Handling Unit Safety Information

Observe all safety directions and comply with the corresponding general safety regulations in order to prevent personal injury and damage to property.

- Safety devices may not be removed, bypassed or taken out of operation.
- Apparatus and system components may only be used in a technically fault-free state. Faults that can affect safety must be rectified immediately.
- Observe the required safety instructions against excessively high contact voltages.
- The plant may not be in operation if the standard safety devices are out of operation or if their effects are influenced in some other way.
- All handling that affects the prescribed disconnection of the protective extra-low voltage (AC 24 V) must be avoided.
- **Disconnect the supply voltage before opening the apparatus cabinet. Never work when the power is on!**
- Avoid electromagnetic and other interference voltages in signal and connection cables.
- Assembly and installation of system and plant components may only be performed in accordance with corresponding installation instructions and instructions for use.
- Every electric part of the system must be protected against static charging: electronic components, open printed circuit boards, freely accessible connectors and apparatus components that are connected with the internal connection.
- All equipment that is connected to the system must be CE marked and comply with the Machine Safety Directive.

## 2. Introduction

This operating manual provides the basic information that allows the control of the Daikin Air Handling Unit (AHU).

AHUs are used for air conditioning and air handling in terms of temperature, humidity and CO<sub>2</sub> level control. There are four types of AHU, based on the external devices used to produce cooling or heating:

1. **AH-ERQ-U**

The AH-(ERQ)-U is connected with the Daikin ERQ condensing unit;

2. **AH-W-U**

The AH-(Water)-U is connected with an external device that provides hot water or cold water used in a water heat exchanger;

3. **AH-DX-U**

The AH-(Direct eXpansion)-U is connected with an external condenserless unit;

4. **AH-WDX-U**

This type of AH-(Water Direct eXpansion)-U can be connected to both water and direct expansion devices.

The diagrams in Figures 1 and 2 show two possible AHU layouts:

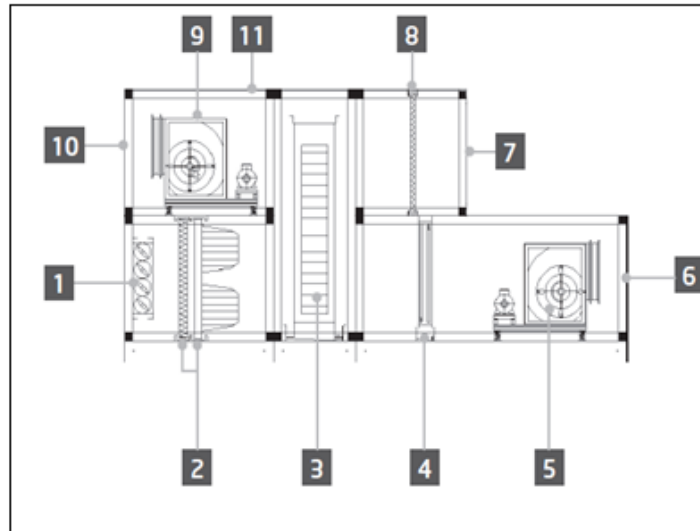

Figure 1: AHU example layout #1

- |                             |                                   |
|-----------------------------|-----------------------------------|
| 1. Fresh air inlet / damper | 7. Return air inlet               |
| 2. Bag filter               | 8. Filter                         |
| 3. Heat wheel               | 9. Return fan                     |
| 4. Dx coil                  | 10. Exhaust air outlet            |
| 5. Supply fan               | 11. Roof for outdoor installation |
| 6. Supply air outlet        |                                   |

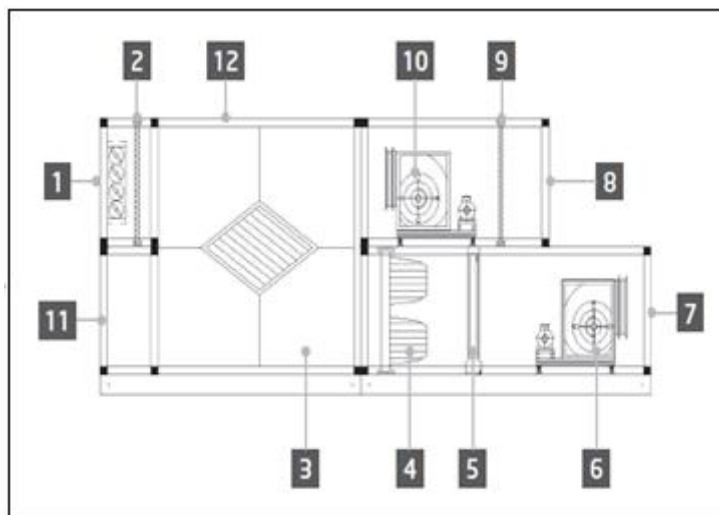

Figure 2: AHU example layout #2

- |                                  |               |
|----------------------------------|---------------|
| 1. Fresh air inlet / damper      | 5. Dx coil    |
| 2. Panel-filter                  | 6. Supply fan |
| 3. Heat recovery plate exchanger |               |
| 4. Bag filter                    |               |

- |                      |                                   |
|----------------------|-----------------------------------|
| 7. Supply air outlet | 10. Return fan                    |
| 8. Return air inlet  | 11. Return air outlet             |
| 9. Panel filter      | 12. Roof for outdoor installation |

The main components of a Daikin AHU are:

- **Air filters:** pre-filter, fine filter, bag filter, HEPA filter.  
Every AHU unit can be equipped with several types of filters used to clean the air from little particles of dust, pollen etc.
- **Device for heat/cool recovery:** Wheel, Cube Plate Exchanger, RAR coil or Mixing Damper.  
These devices are used to recover cooling or heating from the return air. Part of the exhaust air is mixed with fresh air so that the inlet air temperature is closer to the desired one.
- **Water/Electrical/Dx coils.**  
These are the devices used for air temperature conditioning.
- **Supply and return Fan.**  
These devices are used to regulate the air volume, and often they are controlled via an inverter.
- **Supply and return air dampers.**  
These devices allow the air flow through the AHU when being activated.

### 3. User interface

In this chapter are explained the different operative modes available to the user for AHU control.

#### 3.1 Controller POL687/638 Interfaces

Two different controllers are available for AHU control, depending on the chosen model: POL687 for AHU-Modular (or Compact for software version previous to Airstream 0.10.B), POL638 for AHU-Professional.

Next figure shows POL687 controller interface schematic.

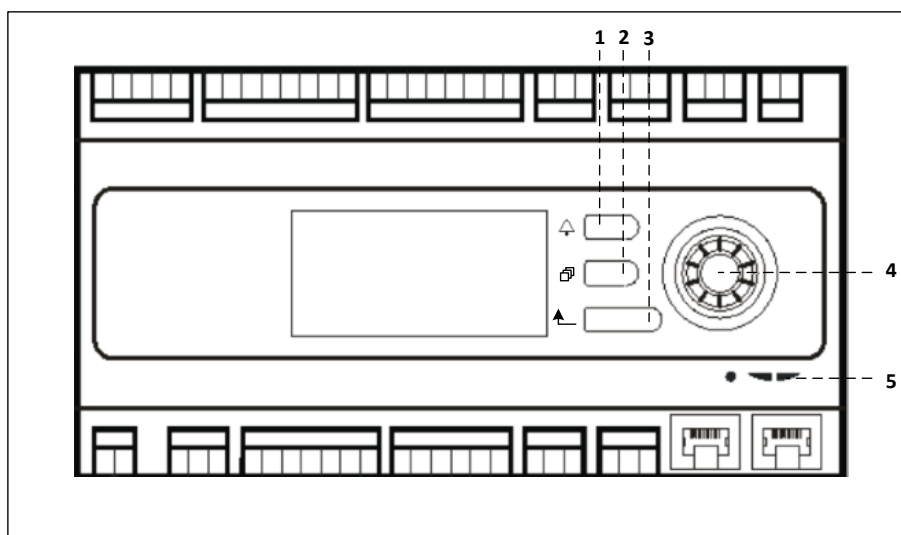

Controller POL687

With reference to figure above, it is possible to identify:

- 1) Alarm button: this button allows the user to directly access the **Alarms** menu.
- 2) Main Menu button: this button is used to return to the **Main Menu** screen at all times.

- 3) Return button: this button allows the user to go back to the previous screen.
- 4) Wheel select button: this button allows the user to surf through the menus; pressing the button will enter to the next page, turning it allows the user to scroll up or down through the current page.
- 5) BSP/BUS LED: these LEDs allow the user to monitor POL687 controller status.

Next figure shows POL638 controller interface.

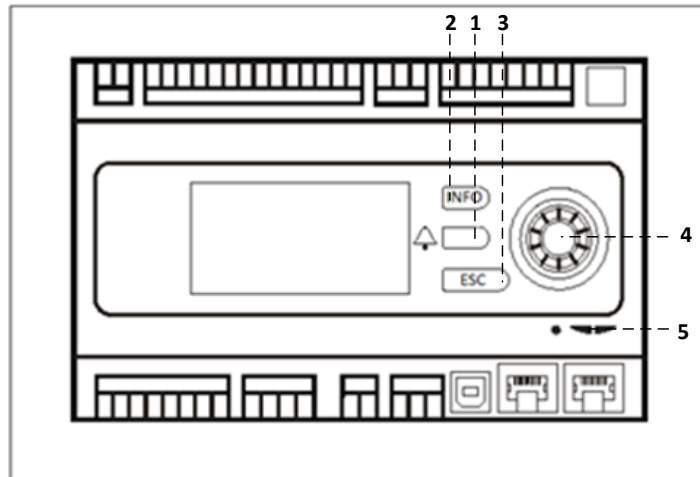

Controller POL638

The differences between POL687 and POL638 interfaces are the “Main Menu” and “Return” buttons, which are mapped respectively to “INFO” and “ESC” buttons.

### 3.2 External Human Machine Interfaces

The Human Machine Interfaces (HMI) are devices that can be connected to the main controller (POL687/638) in order to create a remote interface between the controller and the user.

Two different remote interfaces are available: POL871 and POL895. Both will replicate exactly the same page that is seen on the principal controller and must be connected to the “T-HI” output of the controller.

#### 3.2.1 6-Button LCD HMI (POL871)

The following figure shows the POL871, a 6-buttons LCD interface, and how to connect it to the main controller through a simple Ethernet cable:

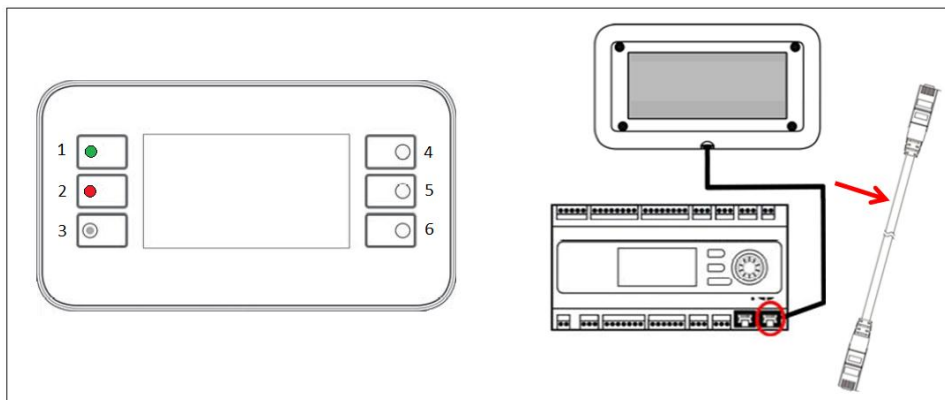

With reference to the above, it is possible to identify the following buttons:

1. Button 1: Main menu.  
This button has an internal LED that indicates the status of the AHU:
  - LED green: AHU running
  - LED blinking orange: AHU Alarm
2. Button 2: Use this button to go directly to the alarms page.
3. Button 3: Back button.
4. Button 4: Scroll up button / increase values.
5. Button 5: Scroll down button / decrease value.
6. Button 6: Enter / validate button.

### 3.2.2 Push & Roll key HMI (POL895)

The POL895 is an external interfaces with a push & roll key which replicates the integrated controller HMI navigation (if provided). All views, data and setpoint adjustments available on main controller HMIs are available on the remote panel. Navigation is identical to the main controller as described in this manual. The initial screen when the remote is turned on shows the units connected to it. Highlight the desired unit and press the wheel to access it.



***Long press of the ESC button will show the list of the connected controllers. Use the wheel to select the desired controller.***

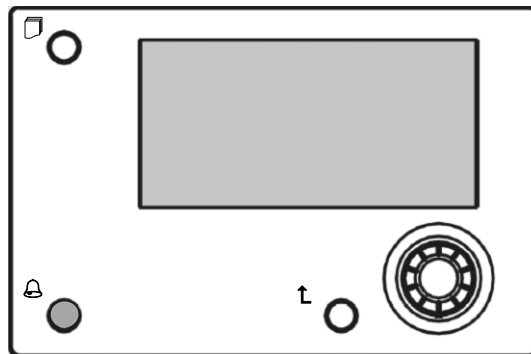

The Remote HMI can be extended up to 700m using the Process Bus connection (PB) available on the main controller.



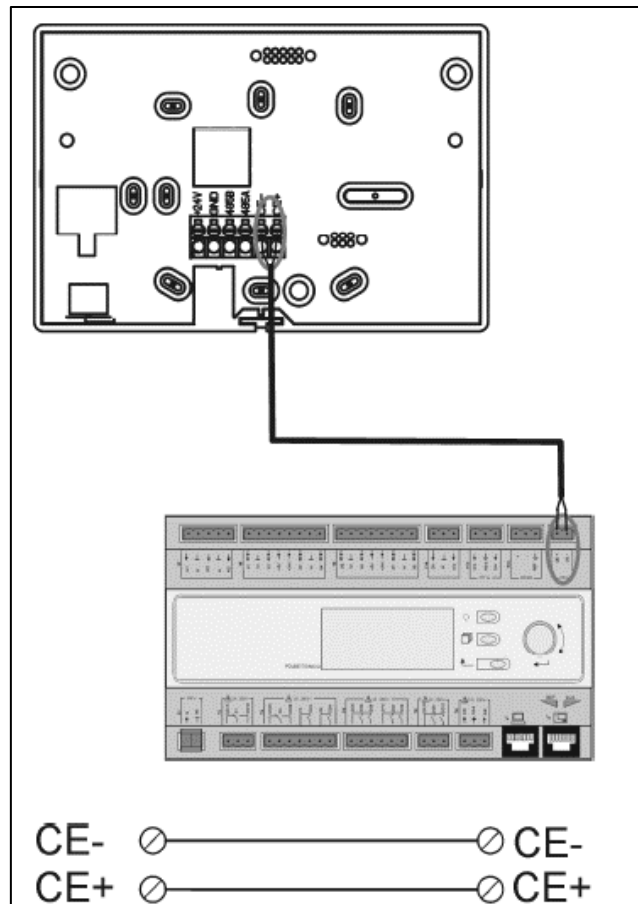

With a daisy-chain connection as below, a single HMI can be connected up to 8 units. Refer to the specific HMI manual for additional details.

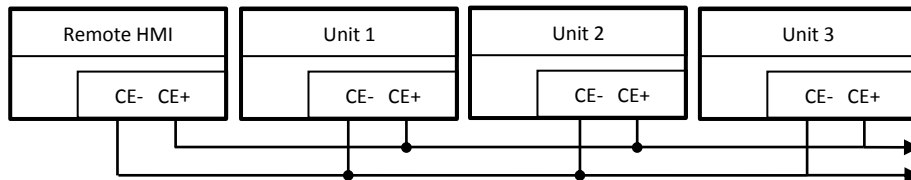

The Remote interface can be also connected with an Ethernet cable (twisted pair). Maximum length changes depending on cable characteristic:

- Shielded cable: max length 50m,
- Non-shielded cable: max length 3m.

Connection in this case has to be executed as shown in the following image.

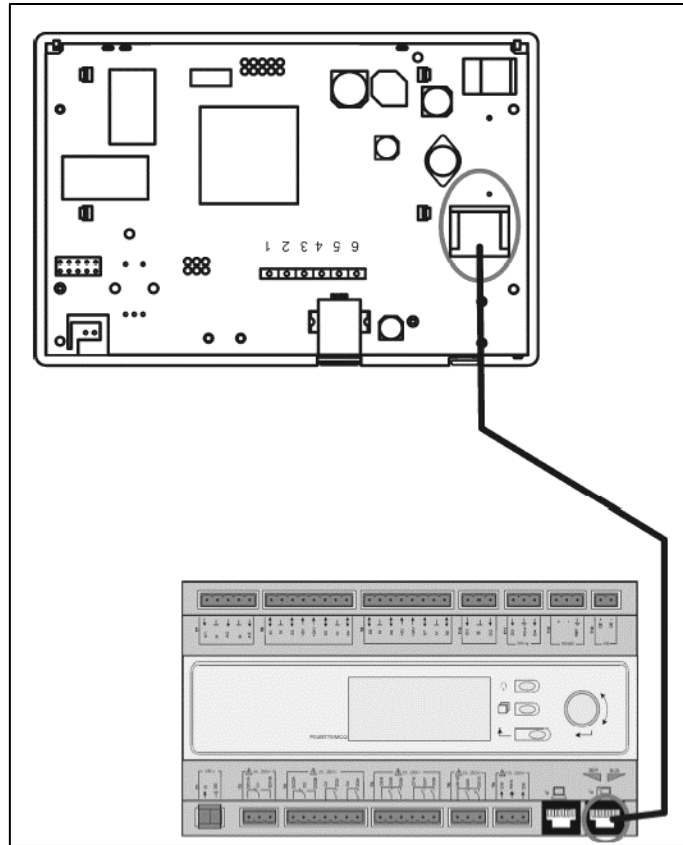

### 3.3 WEB-Human Machine Interface

The main controller can be connected to a PC using an Ethernet cable on the “Ethernet” output of the controller itself .

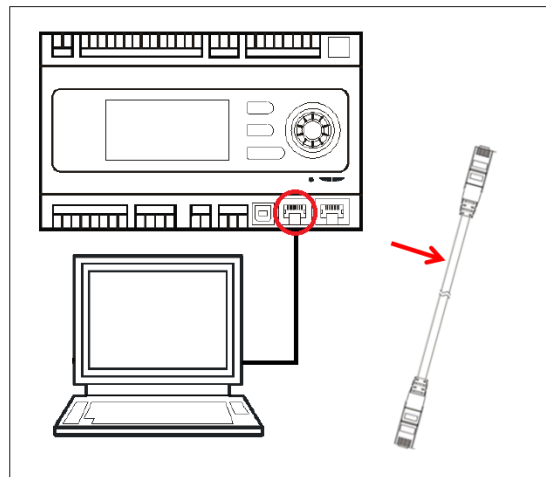

To access to the controller menu through the WEB-HMI it is necessary to follow the following steps:

1. Set a static IP (Windows 7):

**Start -> Control Panel -> View network status and tasks -> Local Area Connection**

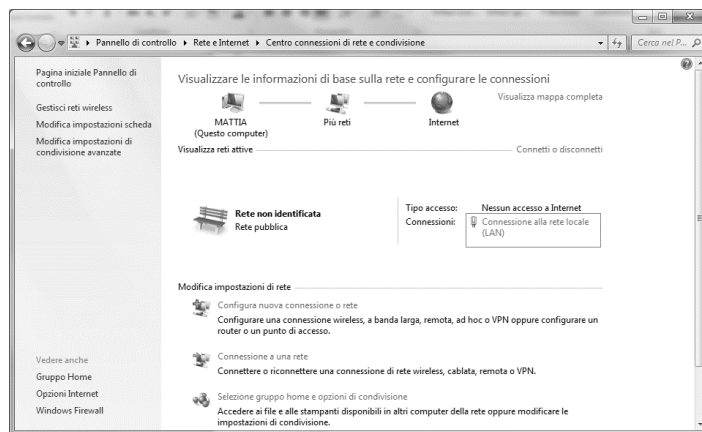
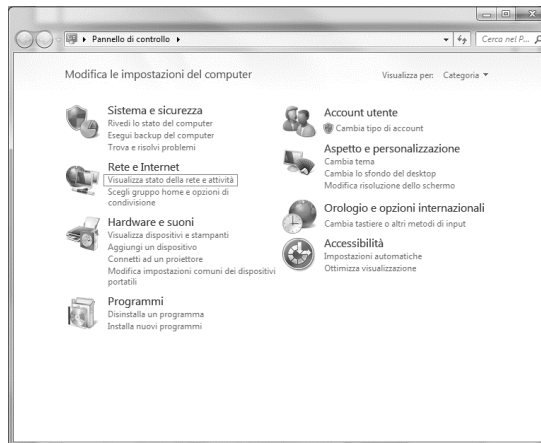

### Properties -> Internet Protocol 4(TCP/IPv4) -> Properties

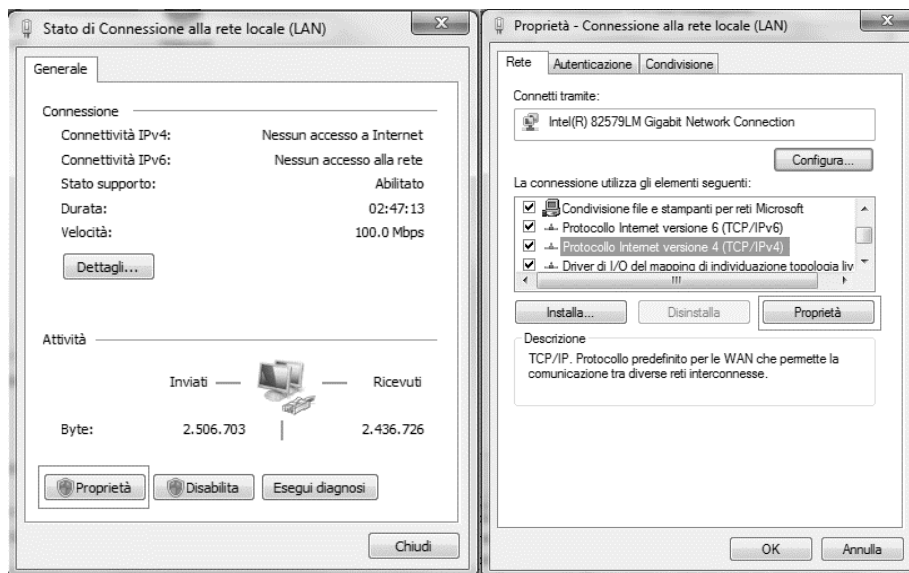

2. Set "Use the following IP address" and "Use the following DNS server addresses" and manually insert:
  - IP address = 192.168.1.xxx, where xxx indicates any number between 1 and 254, except 42
  - Subnet mask = 255.255.255.0

## 3. Press Ok

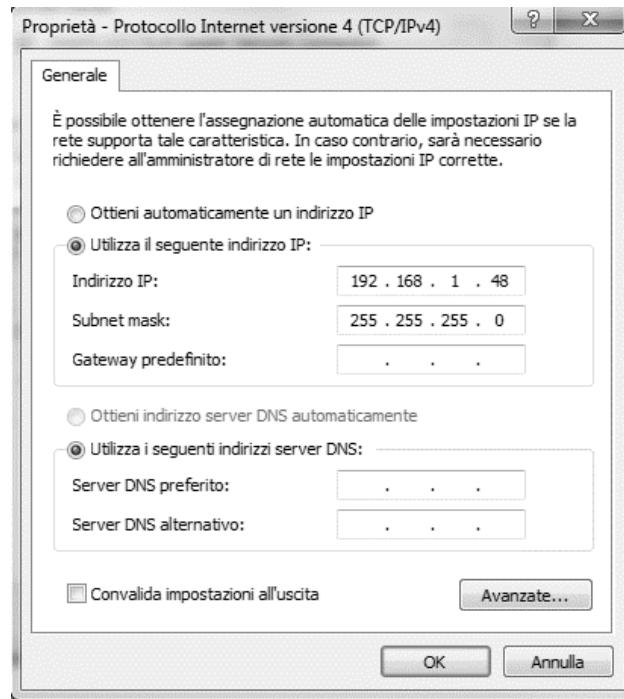

Before launching the WEB-HMI, the user must check if any proxy servers are disabled on the internet browser:

## 1. For Internet Explorer select:

**Tools -> Internet Options -> Connections -> Lan settings**

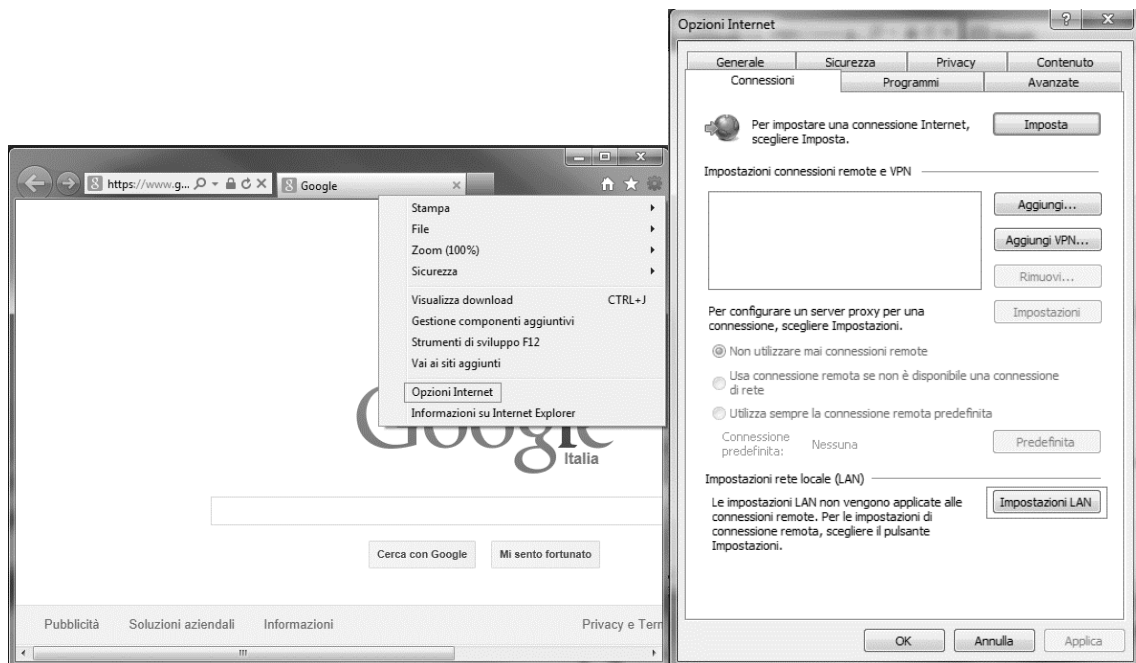

## 2. Disable "Use a proxy server for your LAN (These settings will not apply to dial-up or VPN connections)"



3. Type <http://192.168.1.42> in the internet browser bar and, when asked, insert the following user name and password:
  - User name: **ADMIN**
  - Password: **SBTAdmin!**

The following page should appear.



### 3.4 Communication Modules

Any of the modules described in this section can be connected directly to the left side of the main controller to allow a BAS or other remote interface to function. To make the connection is required to remove the knockout covers on both unit controller and communication module, so the installation will results as follows:

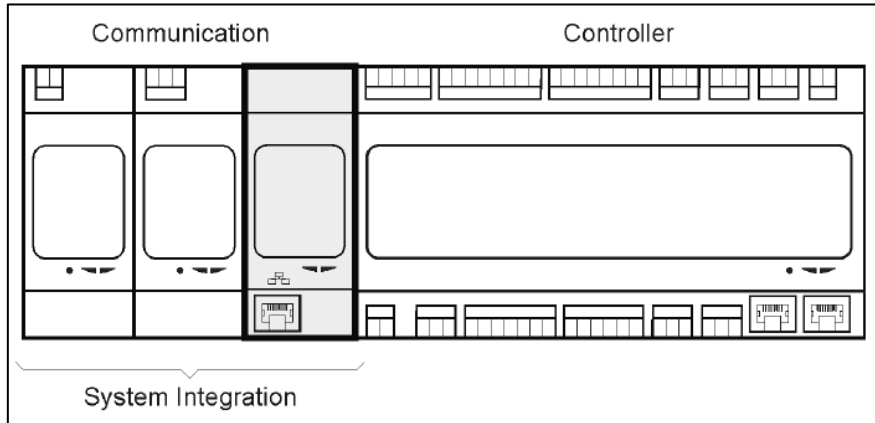

The controller should automatically detect new modules after booting up. The configuration strictly depends on the communication protocol used. Refer to **Section 16.2** for additional details.

Module	Part Number	Usage
Modbus	POL902.00/MCQ	Optional
BACnet/IP	POL908.00/MCQ	Optional

Separate documents contains all the information about the different protocols supported and a full list of available variables.

#### 3.4.1 Modbus module installation



In case of Modbus connection with a BMS, the corresponding module has to be installed on the unit (POL902). It has to be connected to the Unit Controller as indicated in the previous section.

The module has two different ports available but only the top port is programmed and operational. A dedicated menu allows to properly setup the communication parameters (Refer to **Section 16.2.1**).

### 3.4.2 BACnet IP module installation



In case of BACnet connection with a BMS, the corresponding module has to be installed on the unit (POL908). It has to be connected to the Unit Controller as indicated in the previous section.

A dedicated menu allows to properly setup the communication parameters (Refer to **Section 16.2.2**).

### 3.5 Basic Control System Diagnostic

Unit controller, extension modules and communication modules are equipped with two status LED, BSP and BUS, to indicate the operational status of the devices (see section 3.1 for their location). The “BUS” LED indicates the status of the communication with the controller. The meaning of the two status LED is indicated below.

#### - **MAIN CONTROLLER**

##### - **BSP LED**

LED Color	Mode
Solid Green	Application running
Solid Yellow	Application loaded but not running (*) or BSP Upgrade mode active
Solid Red	Hardware Error (*)
Flashing Green	BSP startup phase. The controller needs time for starting.
Flashing Yellow	Application not loaded (*)
Flashing Yellow/Red	Fail safe mode (in case that the BSP upgrade was interrupted)
Flashing Red	BSP Error (software error*)
Flashing Red/Green	Application/BSP update or initialization

(\*) Contact Service.

#### - **EXTENSION MODULES**

##### - **BSP LED**

LED Color	Mode
Solid Green	BSP running
Solid Red	Hardware Error (*)
Flashing Red	BSP Error (*)
Flashing Red/Green	BSP upgrade mode

**- BUS LED**

LED Color	Mode
Solid Green	Communication running, I/O working
Solid Yellow	Communication running but parameter from the application wrong or missing, or uncorrect factory calibration
Solid Red	Communication down (*)

**- COMMUNICATION MODULES****- BSP LED (same for all modules)**

LED Color	Mode
Solid Green	BPS running, communication with controller
Solid Yellow	BSP running, no communication with controller (*)
Solid Red	Hardware Error (*)
Flashing Red	BSP Error (*)
Flashing Red/Green	Application/BSP update

(\*) Contact Service.

**- BUS LED (BACnet IP)**

LED Color	Mode
Solid Green	Ready for Communication. The BACnet Server is started. It doesn't indicate an active communication
Solid Yellow	Startup. The LED stays yellow until the module receives an IP Address, therefore a link must be established.
Solid Red	BACnet Server down. Automatic restart after 3 seconds is initiated.

**- BUS LED (Modbus)**

LED Color	Mode
Solid Green	All Communication running
Solid Yellow	Startup, or one configured channel not communicating to the Master
Solid Red	All configured Communications down (no communication to the Master). The timeout can be configured. In case that the timeout is zero, the timeout is disabled.



## 4. Control Functions

This section describes the main control functions available in Daikin Air Handling Units. A typical activation sequence of the devices installed in Daikin AHU for thermoregulation control is showed below.

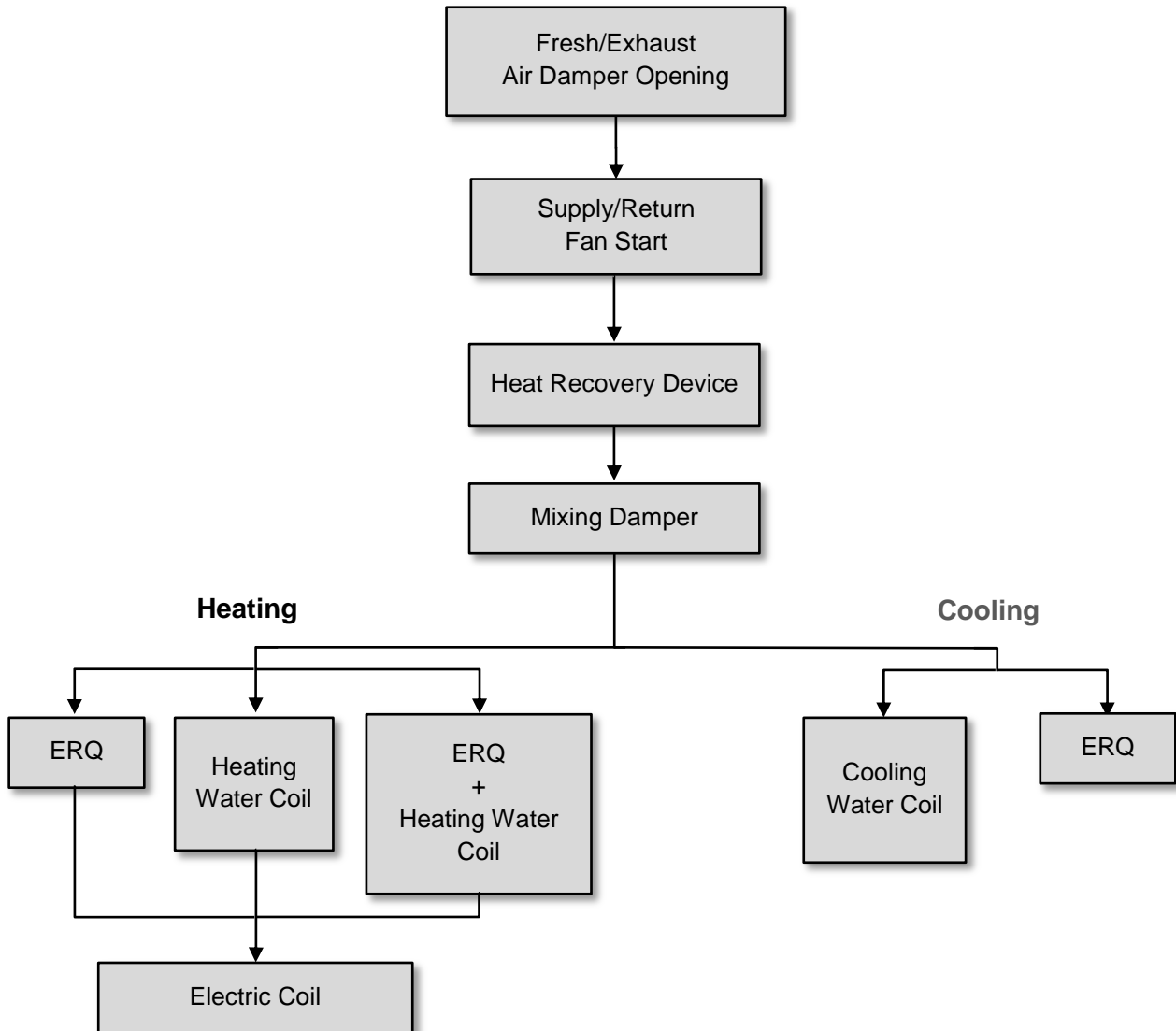

The starting sequence is performed according to an energy saving management logic, in order to satisfy the desired temperature setpoint.

As soon as a device is fully operational (i.e. operates at 100%), the next device starts according to the sequence shown in the figure above. The same sequence describes also the devices turn-off order by following the opposite direction, ensuring that the upper devices are directly controlled only when the lowest ones are not working. This ensure that the temperature setpoint is always satisfied with the lowest energy consumption.



***The activation sequence strictly depends on the devices actually installed in your AHU, so it may changes accordingly.***

## 4.1 Air Quality Control Function

The Air Quality control function provides the AHU with the capability of monitoring and control the actual level of CO<sub>2</sub> concentration in the environment by modulating the devices that control the air flow (fans and dampers) in order to facilitate the air exchange between inside and outside, while ensuring in the meantime the respect of the temperature setpoint selected.

In particular, when the CO<sub>2</sub> level (in ppm) is higher than the desired setpoint, the actual fan setpoint is increased proportionally in order to increment clean air volume coming from the outside (Supply air duct) and at the same time extract more rapidly the environment exhaust air (Return air duct). During this state, the dampers (both mixing and external) are modulated in order to increase fresh air flow.

For additional information on air quality control logic and parameters configuration refer to **Air Quality Control** section (15.2).



*The Air Quality control function is available only if the AHU is provided with a CO<sub>2</sub> sensor.*

## 4.2 Humidity Control Function

The AHU software is provided with both humidification and dehumidification functions in order to control the environment relative humidity and satisfy the desired humidity setpoint. These functions may be both available or not, depending on the configuration of the AHU.

### - Humidification Control

During AHU winter mode, the controller monitors the humidity sensor readings and activates the control of the humidifier as soon as this value drops below the desired setpoint.

The humidification function can be configured to be active also during AHU summer mode.

The humidifier can also be used to refresh the return air during AHU summer mode in order to increase the effectiveness of the heat recovery device by enabling the adiabatic recovery function (via AHU configuration).

### - Dehumidification Control

During AHU summer mode, the controller monitors the humidity sensor readings and activates the dehumidification control when this values becomes higher than the desired setpoint. The control acts differently based on the cooling coil installed.

- ERQ: the dehumidification control is activated only if the cooling temperature setpoint has already been reached. At this state, if the dehumidification is needed, the control continues to increase the ERQs load in order to lower the air humidity value, while activating the post-heating coil (electric or water) to prevent the air temperature to become too low.
- Water coil or DX: the cooling coil signal consists of the maximum value coming from the cooling controller and the dehumidification controller. When the dehumidification logic is controlling, the post-heating coil is activated to prevent the air temperature to become too low.

The dehumidification function can be configured to be active also during AHU winter mode.

For additional information on humidity control monitoring and parameters configuration refer to **Humidity Control** section (15.3).



*The Humidity control function is available only if the AHU is equipped with all the necessary devices.*

### 4.3 Summer/Winter mode changeover functions

The AHU software provides several options for summer/winter changeover control:

- **Auto Mode**  
The controller monitors one of the several temperatures available on the AHU (Room, Return or Outside). The value of this temperature is compared with two limits (one for summer and one for winter) and, depending on the result of this comparison, the controller chooses the cool/heat state for the next period.
- **Manual Mode**  
The changeover is managed via controller interface or through the Room Unit device (if installed).
- **Pursuit Mode**  
This logic can be used when it is desired to follow a temperature setpoint, regardless of the actual heating/cooling mode of the unit.  
The unit will automatically switch to Summer/Winter state when the actual controlled temperature has passed respectively the to Summer/to Winter thresholds, which are calculated based on the actual temperature setpoint selected.
- **BMS**  
The changeover is managed via a Building Management System (BMS) through BACnet or Modbus protocol communication.

For additional information on summer/winter changeover logics and settings refer to **Summer/Winter state** section (11).



*The available summer/winter changeover modes depend on the components and functions configured in the AHU, so the number and configuration may change accordingly.*

## 5. Main Menu screen



***IMPORTANT! This manual refers to the user interface implemented in software version "Airstream 2.00.A" and later, so for previous software versions the presence and arrangement of some menu items may be different.***

Through Main Menu screen the user can access to all the information necessary for monitoring the AHU status, in addition to managing the unit operative mode.

In particular, the user can:

- Control the AHU operative mode
- Change the AHU Setpoint
- Change the Summer/Winter state
- Access to the I/O overview menu
- Program the time scheduler
- Restore alarm conditions

Next chapters will describe any item of the main menu. In the following table the user can find all the items of the main menu screen and the section where it is described.

Main Menu item	Section
<b>Enter Password</b>	Insert the password to gain service level access.
<b>Control Source</b>	Display the actual control source of the AHU. (Section 6)
<b>Actual mode</b>	Display the actual operating mode of the AHU. (Section 7)
<b>Unit State</b>	Display the actual state of the AHU. (Section 8)
<b>Active Setpoint</b>	Display all active setpoints of the AHU. (Section 9)
<b>Actual Ctrl Tmp</b>	Display the actual value of the controlled temperature.
<b>Local Switch</b>	Display/change locally the operating mode of the AHU. (Section 10)
<b>Su/Wi state</b>	Display actual AHU state and change summer/winter changeover options. (Section 11)
<b>Setpoints</b>	Change AHU setpoints. (Section 12)
<b>I/O overview</b>	Monitor all inputs and outputs of the controller. (Section 13)
<b>Time Scheduler</b>	Set the time slots for AHU On/Off turning. (Section 14)

<b>Status/Settings*</b>	Display actual status and manage settings for the devices installed in the AHU. (Section 15)
<b>Commissioning*</b>	Set the configuration parameters of the AHU. (Section 16)
<b>Alarm handling</b>	Visualize and manage every alarm occurrence. (Section 17)
<b>About Unit</b>	Visualize useful information about the controller. (Section 18)

\*Only visible with service password entered.

## 6. Control Source

This item displays the actual control source of the AHU. All possible control source are reported in the table below.

HMI Path: Main Menu -> Ctrl Source

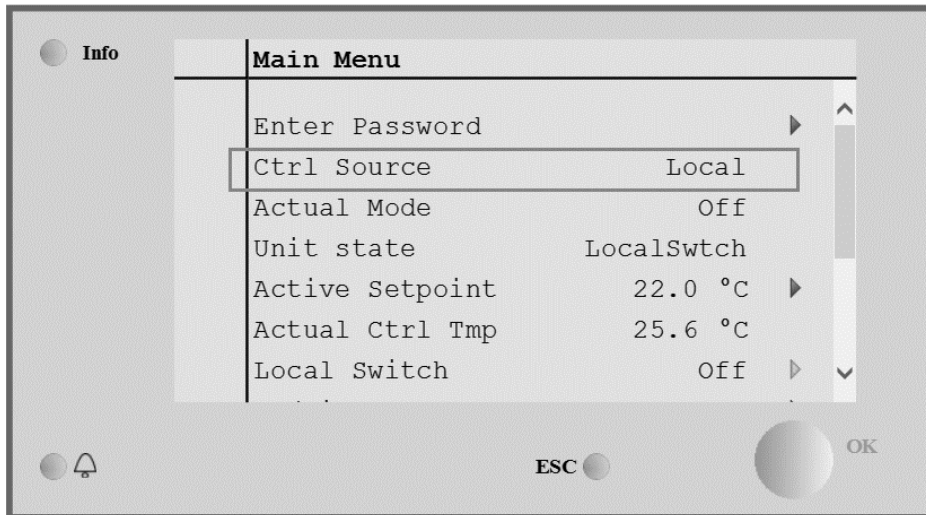

Main Menu item	Value	Description
<b>Control Source</b>	- Local* - BACnet	<p><b>Local:</b> unit control managed directly from the controller interface or automatically via time scheduler. Refer to <b>Local Switch</b> page (<b>Section 10</b>) for more details.</p> <p><b>*Room Unit control:</b> when Control Source is set to Local, the unit can also be controlled through the Room Unit device (POL822), if installed. Refer to <b>Appendix A</b> for more details.</p> <p><b>*Modbus control:</b> when Control Source is set to Local, the unit can also be controlled by a Modbus Master device through Modbus protocol, if the corresponding communication module is installed (POL902). Refer to <b>AHU Modbus protocol operating manual</b> and to <b>Section 16.2.1</b> for more details.</p> <p><b>BACnet:</b> unit control managed through BACnet communication. Refer to <b>AHU BACnet protocol operating manual</b> and to <b>Section 16.2.2</b> for more details.</p>

## 7. Actual Mode

This item (read-only) displays the actual operating mode of the AHU. All possible operating mode are reported in the table below.

*HMI Path: Main Menu -> Actual Mode*

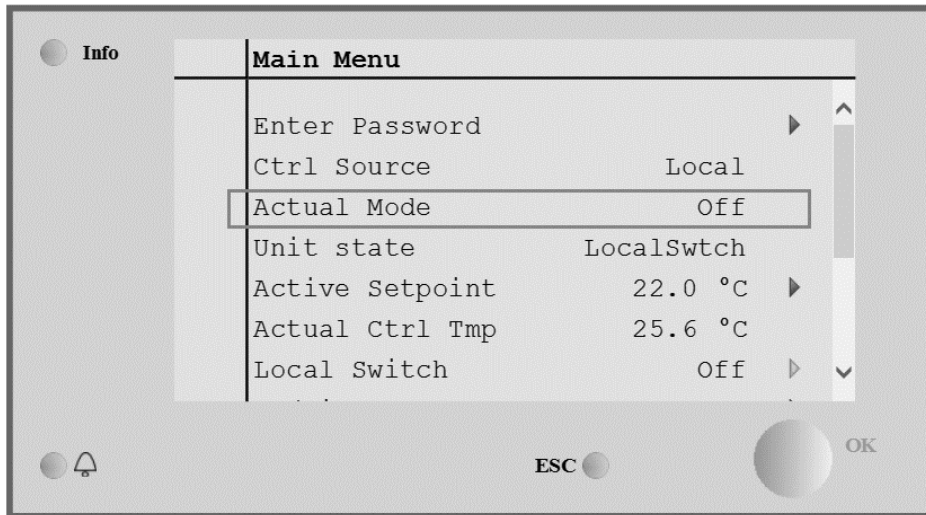

Main Menu item	Value	Description
<b>Actual Mode</b>	- Off	<b>Off:</b> AHU in Off mode.
	- On	All devices installed on the AHU (fans, cooling/heating coil, dampers, etc..) are Off.
	- Ventilation	<b>On:</b> AHU in On mode. Normal functioning: all controls are active.
	- Economy	<b>Ventilation:</b> AHU in Ventilation mode. In this mode only fans are running.
		<b>Economy:</b> AHU in Economy mode. Normal functioning: all controls are active, but the AHU works referring to the <b>Economy</b> set points. Refer to <b>Setpoints</b> page ( <b>Section 12</b> ) for more details.

## 8. Unit State

This item (read-only) displays the actual state of the AHU. All possible states are reported in the table below.

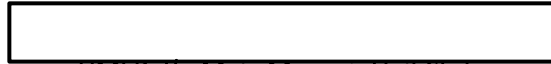

HMI Path: Main Menu -> Unit State

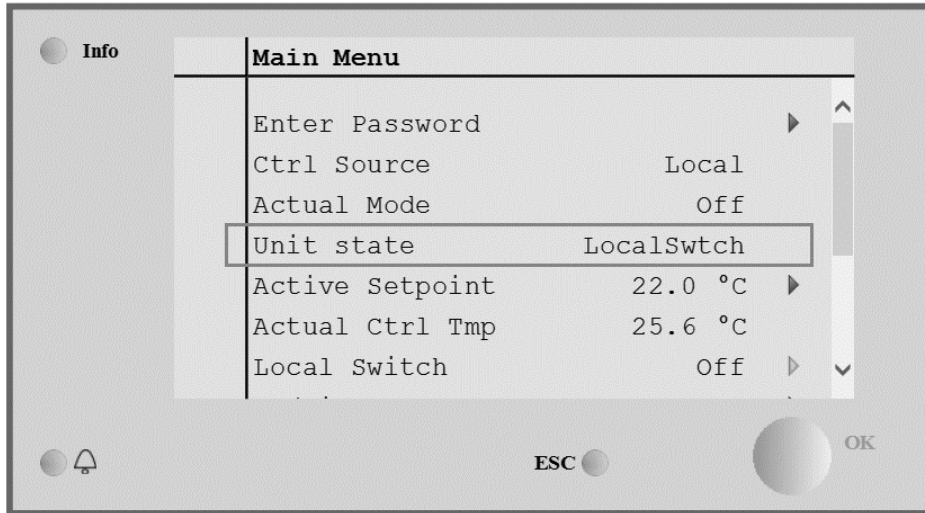

Main Menu item	Value	Description
<b>Unit State</b>	- Fire	<b>Fire:</b> AHU in Fire alarm state.
	- Emergency Alarm	The AHU is in this state when a <b>"Fire Alarm"</b> digital input is detected.
	- Manual	<b>Emergency:</b> AHU in Emergency state
	- Panel Switch	This state indicates that the Emergency button has been pressed.
	- Local Switch	<b>Alarm:</b> AHU in alarm state.
	- BMS	This state is displayed when an alarm has been detected.
	- Scheduler	<b>Manual:</b> AHU in Test mode.
- Ready	The AHU is in this state when <b>Local Switch</b> is set to <b>Test</b> .	
- Occupancy	Refer to <b>Local Switch</b> page ( <b>Section 10</b> ) for more details.	
	<b>Panel Switch:</b> Switch labeled <b>"Enable Switch"</b> located on the Electrical Box is set to zero.	
	<b>Local Switch:</b> AHU controlled manually from interface, Room Unit or a Modbus Master device.	
	Refer to <b>Local Switch</b> ( <b>Section 10</b> ) and <b>Control Source</b> ( <b>Section 6</b> ) pages for more details.	
	<b>BMS:</b> AHU controlled via <b>BACnet</b> .	
	<b>Scheduler:</b> AHU in <b>On</b> state by <b>Time Scheduler</b> .	



Main Menu item	Value	Description
		Refer to <b>Time Scheduler (Section 14)</b> page for more details
		<b>Ready:</b> AHU in <b>Off</b> state by <b>Time Scheduler</b> . Refer to <b>Time Scheduler (Section 14)</b> page for more details.
		<b>Occupancy:</b> AHU in <b>On</b> state by <b>Occupancy</b> function. Refer to <b>Room Unit</b> page for more details. ( <b>Appendix A</b> )

## 9. Active Setpoint

All actual setpoints used by the software to control AHU devices are reported in the **Active Setpoint** page. In the Main Menu screen is displayed the actual setpoint used for controlled temperature.

HMI Path: Main Menu -> Active Setpoint

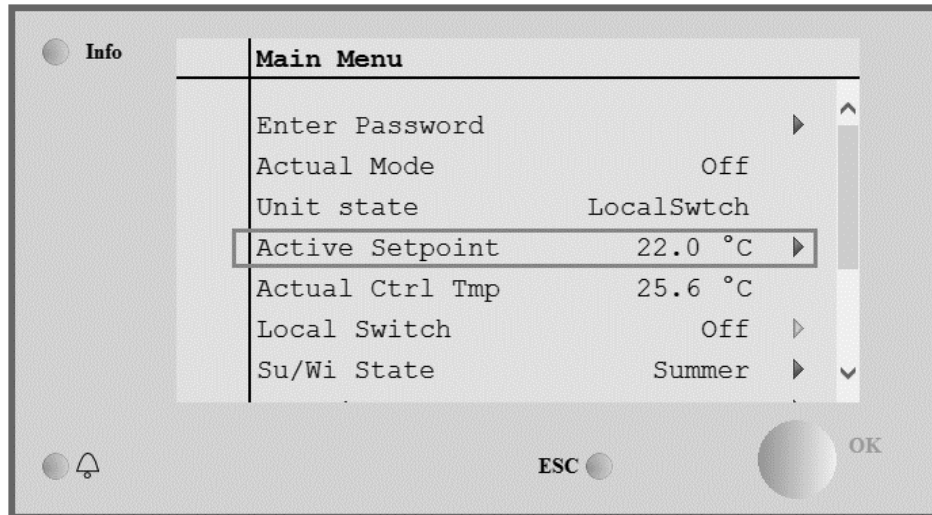

Parameters	Description
<b>Temperature</b>	<p>Display the actual setpoint used for the controlled temperature. This value is the sum of the basic setpoint (given by Summer/Winter state) plus the offset set through the Room unit (R.U.), if present.</p> <ul style="list-style-type: none"> <li>- Summer mode <b>Temperature = Cool (+ R.U. Offset, if present)</b></li> <li>- Winter mode <b>Temperature = Heat (+ R.U. Offset, if present)</b></li> </ul>
<b>Supply Fan</b>	<p>Display the actual setpoint value for the supply fan. This value is the sum of the basic setpoint plus the offset evaluated by the software for compensation (if a compensation function is active).</p> <p><b>Supply Fan = Supply Fan (+ Comp. Offset, if active)</b></p>
<b>Return Fan</b>	<p>Display the actual setpoint value for the return fan. This value is the sum of the basic setpoint plus the offset evaluated by the software for compensation (if a compensation function is active).</p> <p><b>Return Fan = Return Fan (+ Comp. Offset, if active)</b></p>
<b>Humidification</b>	Display the actual humidification setpoint.
<b>Dehumidification</b>	Display the actual dehumidification setpoint.
<b>Air Quality</b>	Display the actual air quality setpoint.

## 10. Local Switch

This item is used to control locally the operating mode of the AHU.



**NOTE!** Any change on this item does not have any effect if the AHU is configured to be controlled by BMS (i.e. Ctrl Source = BACnet).

HMI Path: Main Menu -> Local Switch

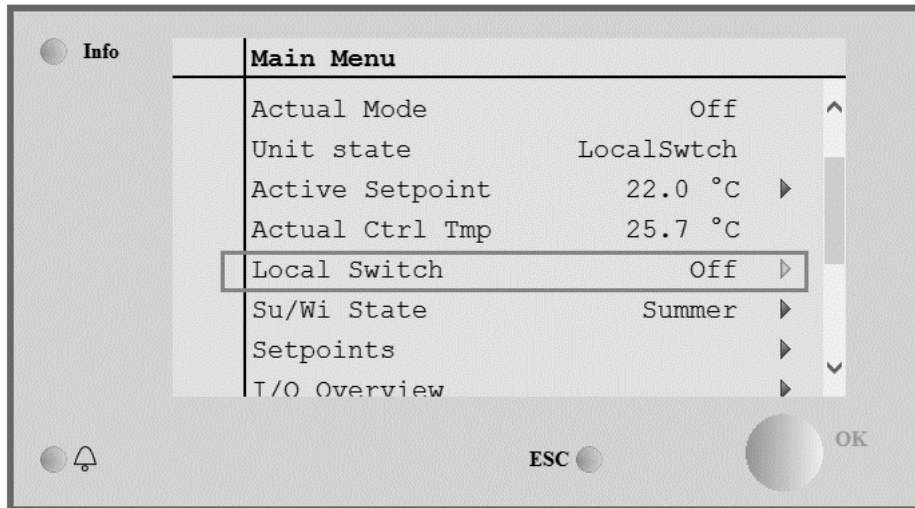

Main Menu item	Value	Description
<b>Local Switch</b>	- Auto	<b>Auto:</b> AHU On-Off state is managed by the time scheduler. Refer to <b>Time Scheduler</b> page for more details.
	- Off	<b>Off:</b> turn off the AHU.
	- On	<b>On:</b> turn on the AHU.
	- Ventilation	In this mode all controls are active and setpoints related to temperature regulation and fans control are the normal setpoints. Refer to <b>Setpoints</b> page ( <b>Section 12</b> ) to change normal setpoints.
	- Economy	<b>Ventilation:</b> Switch the AHU in ventilation mode. In this mode only fans are running. No temperature control is performed.
	- Test	<b>Economy:</b> Switch the AHU in economy mode. In this mode all controls are active, but the setpoints related to temperature regulation and fans control switch from normal setpoints to economy setpoints. Refer to <b>Setpoints</b> page ( <b>Section 12</b> ) to change economy setpoints.
		<b>Test:</b> AHU in Test mode. In this mode every device of the AHU can be manually controlled.
		<b>NOTE!</b> This function is only available with service password entered and the item is visible only if the AHU is OFF.

## 11. Summer/Winter state

The AHU software provides three different options for summer/winter changeover control:

- Automatic changeover based on temperature.  
The controller monitors one of the several temperatures available on the AHU (Room, Return or Outside). The value of this temperature is after compared with two limits (one for summer and one for winter) and, depending on the result of this comparison, the controller chooses the cool/heat state for the next period.
- Manually changeover via HMI or Room Unit.
- Changeover managed via BMS.

All information and settings for this control are available in the following HMI page:

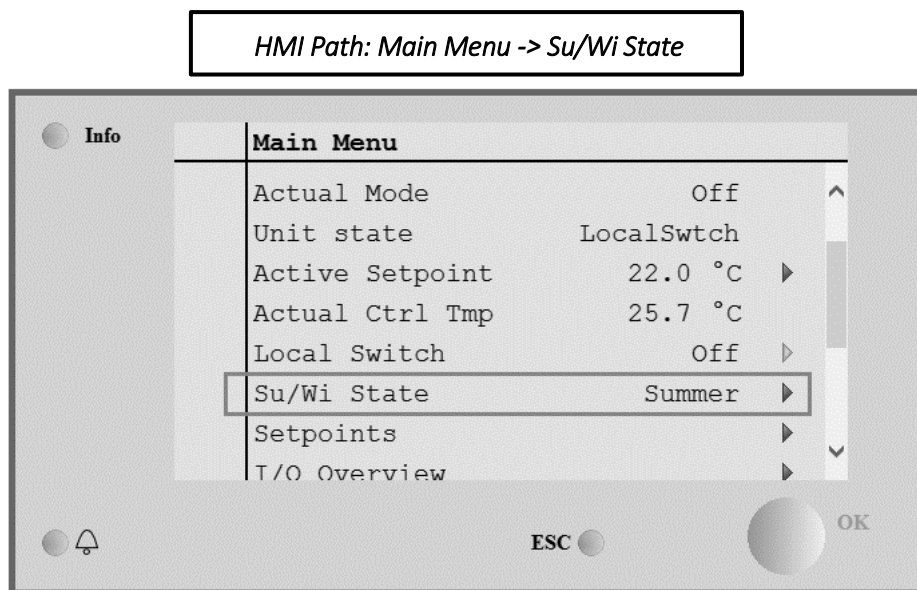

The following table explains all items present in the *Su/Wi state* page and how configure them to obtain the desired control.

Parameters	Value	Description
<b><i>Su/Wi chg source</i></b>	1. Auto 2. HMI 3. BACnet 4. Pursuit*	<p>This parameter defines which mode is used to control the Summer/Winter switch:</p> <ol style="list-style-type: none"> <li>1. Auto: changeover is done automatically by the AHU based on the auto mode configuration</li> <li>2. HMI: Summer/Winter state is set manually by the HMI</li> <li>3. BACnet: Summer/Winter state is set via BACnet communication (BMS)</li> <li>4. Pursuit*: changeover is performed automatically in order to reach and maintain the desired temperature setpoint. Refer to <b>Setpoints</b> page (<b>Section 12</b>) to change <b>Pursuit</b> mode setpoints.</li> </ol> <p><i>*Available from Airstream 1.00.A software version and only if Return or Room temperature control has been selected.</i></p>

Parameters	Value	Description
<b>HMI changeover</b>	- Summer - Winter	Set actual mode of the AHU if <i>Su/Wi chg source = HMI</i>
<b>Network changeover</b>	- Summer - Winter	Display the mode set via BMS. If the <i>Su/Wi chg source = BACnet</i> , this value is the current state of the AHU.
<b>Current State</b>	- Summer - Winter	Display the current state in which the AHU is operating.
<b>Auto mode settings:</b>		
<b>Tmp Used</b>	- Return - Room - Outside	Select the temperature monitored to determine the Summer/Winter state changeover.
<b>Time constant</b>	0...36000 [h]	Define the frequency at which the check is being performed for the Summer/Winter changeover in Auto Mode.  <i>Example:</i> If this parameter is set equal to 6 hours, the controller maintain the same state (Summer or Winter) for six hours. After six hours, the controller perform again the check to determine the next state that will be maintained for next six hours.
<b>Tmp Damped</b>	-64...64 [°C]	Display the value of temperature stored when automatic changeover happened.
<b>Su tmp</b>	-64...64 [°C]	Changes over to summer operation when the selected temperature is greater than this value.
<b>Wi tmp</b>	-64...64 [°C]	Changes over to winter operation when the selected temperature is less than this value.

## 12. Setpoints

All setpoints of the AHU can be set from the HMI. Depending on the AHU configuration some setpoints can be available or not.

*HMI Path: Main Menu -> Setpoints*

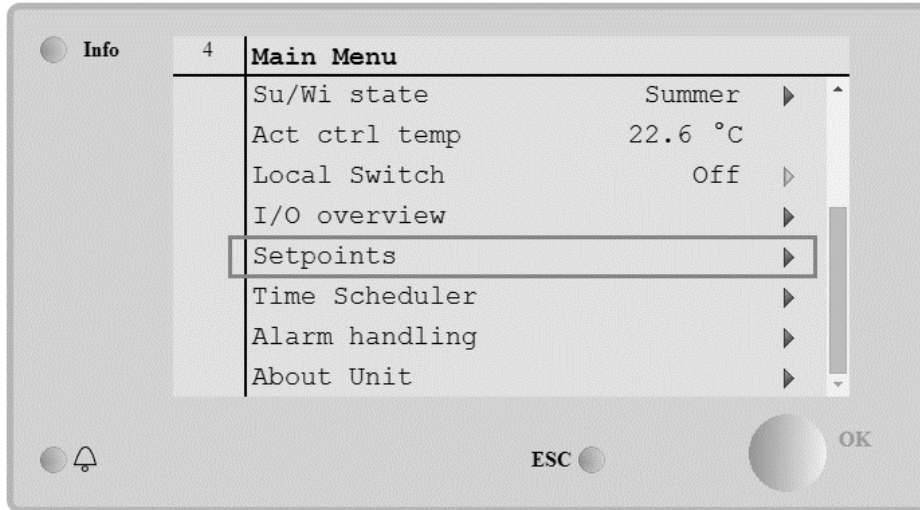

Parameters	Value Range	Description
<b>Temperature:</b>		
<b>Cool</b>	10..40 [°C]	Cooling temperature setpoint. <i>(Available when direct Htg/Clq setpoint control selected)</i>
<b>Heat</b>	10..40 [°C]	Heating temperature setpoint. <i>(Available when direct Htg/Clq setpoint control selected)</i>
<b>Cool Economy</b>	Cool..40 [°C]	Cooling temperature setpoint in Economy mode. <i>(Available when direct Htg/Clq setpoint control selected)</i>
<b>Heat Economy</b>	10..Heat [°C]	Heating temperature setpoint in Economy mode. <i>(Available when direct Htg/Clq setpoint control selected)</i>
<b>Central Temp</b>	10..40 [°C]	Central temperature setpoint. <i>(Available only when temperature regulation with deadzone control selected)</i>
<b>Band Temp</b>	0..20 [°C]	Deadzone temperature setpoint. <i>(Available only when temperature regulation with deadzone control selected)</i>

<b>Central Temp Economy</b>	Cool..40 [°C]			Central temperature setpoint in Economy mode. <i>(Available only when temperature regulation with deadzone control selected)</i>
<b>Band Temp Economy</b>	10..Heat [°C]			Deadzone temperature setpoint in Economy mode. <i>(Available only when temperature regulation with deadzone control selected)</i>
<b>Pursuit</b>	10..40 [°C]			Pursuit mode temperature setpoint. Refer to <b>Summer/Winter state (Section 11)</b> for more details. <i>(Available from Airstream 0.10.B SW version and only if Return or Room temperature control has been selected)</i>
<b>Pursuit Eco</b>	10..40 [°C]			Pursuit mode temperature economy setpoint. Refer to <b>Summer/Winter state (Section 11)</b> for more details. <i>(Available from Airstream 0.10.B SW version and only if Return or Room temperature control has been selected)</i>
<b>Pursuit Band</b>	3,5..10 [°C]			Pursuit mode offset temperature setpoint. This value is added/subtracted from actual Pursuit setpoint in order to estimate Summer/Winter changeover thresholds. Refer to <b>Summer/Winter state (Section 11)</b> for more details. <i>(Available from Airstream 0.10.B SW version and only if Return or Room temperature control has been selected)</i>
<b>R.U. Offset</b>	-6...6 [°C]			Display the actual offset set through the room unit. <i>(Available only with room unit)</i>
<b>Pre-Heating</b>	0..30 [°C]			Temperature threshold for Pre-Heating control activation. <i>(Available only if pre-heating control enabled)</i>
<b>Fan Ventilation:</b>				
<b>Supply</b>	0..100 [%]	0..5000 [Pa]	0..140000 [m <sup>3</sup> /h]	Fans setpoints. Depending on the control type of the

<b>Return</b>	0..100 [%]	0..5000[Pa]	0..140000[m <sup>3</sup> /h]	fan, the setpoint can be expressed in <b>Percentage [%], Pascal [Pa], Cube meter per hour [m<sup>3</sup>/h]</b> . <i>(Not available if fans are controlled in On/Off mode)</i>
<b>Supply Economy</b>	0..100 [%]	0..5000[Pa]	0..140000[m <sup>3</sup> /h]	
<b>Return Economy</b>	0..100 [%]	0..5000[Pa]	0..140000[m <sup>3</sup> /h]	
<b>Supply Defrost</b>	0..100 [%]	0..5000[Pa]	0..140000[m <sup>3</sup> /h]	Supply fan setpoint in case of defrost of the condensing unit ERQ <i>(Available only if fan-defrost limitation control enabled)</i>
<b>Return Defrost</b>	0..100 [%]	0..5000[Pa]	0..140000[m <sup>3</sup> /h]	Return fan setpoint in case of defrost of the condensing unit ERQ <i>(Available only if fan-defrost limitation control enabled)</i>
<b>Others:</b>				
<b>Dehumidification</b>	- 0...100 [%rH] - Humidification...100 [%rH] <i>(if humidification control enabled)</i>			Dehumidification setpoint <i>(Available only if dehumidification control enabled)</i>
<b>Humidification</b>	- 0...100 [%rH] - 0...Dehumidification [%rH] ] <i>(if dehumidification control enabled)</i>			Humidification setpoint. <i>(Available only if humidification control enabled)</i>
<b>Air Quality</b>	0..3000 [ppm]			Air control quality setpoint. Limit of ppm (parts per million) for the CO <sub>2</sub> . <i>(Available only if CO<sub>2</sub> control enabled)</i>
<b>Fan fire setpoint</b>	0..100 [%]			Fans setpoints when fire alarm detected. <i>(Available only if Fire Alarm enabled)</i>



## 13. I/O Overview

This menu allows the user to monitor all analog/digital inputs and outputs of the controller. The list can be different for each specific AHU as it depends on the installed components of the unit which are activated during the commissioning.

*HMI Path: Main Menu -> I/O overview*

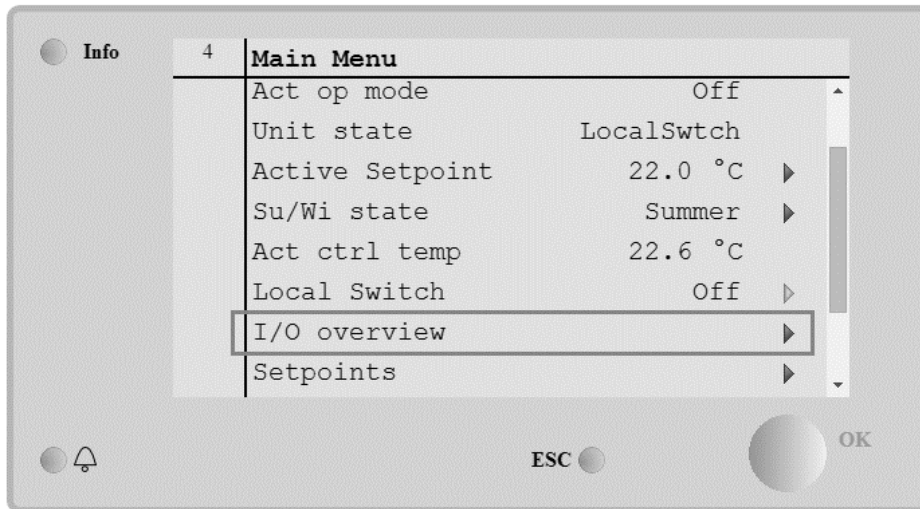

Parameters	Description
<b>Digital inputs</b>	Monitor all digital inputs of the controller. Digital inputs can be connected to alarm signals coming from different installed devices in the AHU (Fan, Damper, Pressure Switch, Water Pump, etc...), or to external switches (Emergency stop, Unit enable).
<b>Analog inputs</b>	Contains the values of all installed sensors: temperature, pressure, air flow, CO2, humidity.
<b>Digital outputs</b>	Contains the values of all digital outputs used to command the several devices of the AHU (ERQ on/off, Pump on/off, Fan on/off, etc...).
<b>Analog outputs</b>	Contains the values of all analog outputs used to command different devices of the AHU (Fan speed, damper opening, percentage of heat recovery, etc...).

## 14. Time Scheduler

The time scheduler is a function that allows the user to set the time slots at which the AHU can be turned ON or OFF. If the scheduler is set, the AHU will be turned On/Off automatically by following the time slot configuration. In the next tables are reported the items of the time scheduler menu and their description. The time scheduler page contains also the configuration pages for single day time scheduling.

*HMI Path: Main Menu -> Time Scheduler*

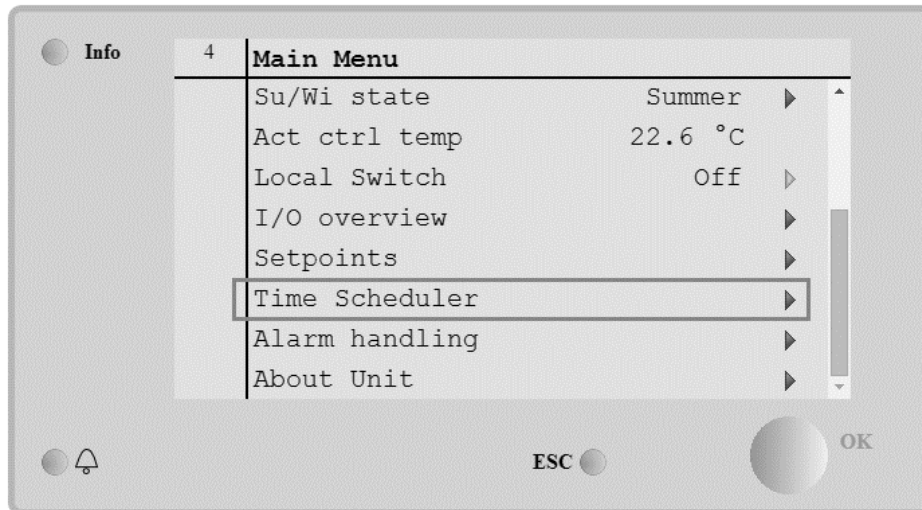

Parameter	Value	Function
<b>TS actual state</b>	- Off - On - Ventilation - Economy	Actual operating mode from time scheduler function.
<b>Monday</b>	- Active - Passive	Active if the present day is Monday. Refer to <b>Day Scheduler (Section 14.1)</b> for more details.
<b>Copy schedule</b>	- Off - On	Copy Monday schedule to all week days.
<b>Tuesday</b>	- Active - Passive	Active if the present day is Tuesday. Refer to <b>Day Scheduler (Section 14.1)</b> for more details.
....	....	....
<b>Sunday</b>	- Active - Passive	Active if the present day is Sunday. Refer to <b>Day Scheduler (Section 14.1)</b> for more details.
<b>Exception</b>	- Passive - Active	Active if the present day is an exception day. Refer to both <b>Day Scheduler (Section 14.1)</b> and <b>Calendar Exception and Calendar Fix off (Section 14.2)</b> for more details.
<b>Period: Start</b>		Start date for the weekly schedule. If equals to *, *.00, weekly schedules is always enabled.
<b>Period: End</b>		End date for the weekly schedule. If equals to *, *.00, weekly schedules is never disabled.
<b>Calendar exception</b>	- Passive - Active	Active if the present day is an exception day. Refer to <b>Calendar Exception/Fix off (Section 14.2)</b> for more details.
<b>Calendar fix off</b>	- Passive - Active	Active if the present day is a fix off day. Refer to <b>Calendar Exception/Fix off (Section 14.2)</b> for more details.

### 14.1 Day Scheduler

By entering in each day page, normal or exception, it is possible to set up to 6 time slots.

Parameter	Range	Function
<b>Time 1</b>	00:00	<b>SPECIAL CASE:</b> this entry must always be set to 00:00!
<b>Value 1</b>	- Off - On - Ventilation	Switching command for Time 1.

	- Economy	
<b>Time 2</b>	00:00 - 23:59	Switching time 2 (*:.*-> Entry disabled)
<b>Value 2</b>	- Off - On - Ventilation - Economy	Switching command for Time 2.
...		
<b>Time 6</b>	00:00 - 23:59	Switching time 6 (*:.*-> Entry disabled)
<b>Value 6</b>	- Off - On - Ventilation - Economy	Switching command for Time 6

Below is an example of a day scheduler setting. In this case the AHU will be turned ON from 9.30 until 13.00 and in Economy mode from 14:00 until to 18:40.

Parameter	Value
Time 1	00:00
Value 1	Off
Time 2	09:30
Value 2	On
Time 3	13:00
Value 3	Off
Time 4	14:00
Value 4	Economy
Time 5	18:40
Value 5	Off
Time 6	*.*
Value 6	Off

**ATTENTION!** If a time value is set incorrectly (i.e. it is less than the previous) the AHU will not work properly and it could be always keep ON or OFF.

## 14.2 Calendar exception and Calendar fix off

Exception days are defined in the calendar items. These may include a specific date, periods or certain days of the week.

When an exception day occurs, the "Exception" day scheduler configuration override the weekly schedule. The time slots at which occurs the exception days can be configured in the "Calendar exception" page. The "Calendar fix Off" page is a special exception day configuration that allows to switch off the plant at specific time slots.

Entering in the “Calendar exception” or “Calendar fix off” page allows the user to find the items reported in the table below.

Parameter	Range	Function
<b>Present value</b>	- Passive - Active	Displays whether a calendar entry is currently enabled: - No calendar entry is currently enabled. - A calendar entry is currently enabled.
<b>Choice-x</b>	- Date - Range - Week Day - Passive	Specifies the entry for the exception: - Date: a certain day (e.g. Friday). - Range: a period (e.g. vacation). - Week Day: a certain day of the week (e.g. every Monday). - Passive: entries are ignored. This value should be set last, after the date is entered.
<b>(Start) date</b>		If <b>Choice-x = date</b> -> Enter data for a single day. If <b>Choice-x = range</b> -> Enter start date for the period.
<b>End date</b>		For <b>Choice-x = range</b> only -> Enter end date for the period. End date must always be after the start date.
<b>Week day</b>		For <b>Choice-x = weekday</b> only -> Enter the day of the week.

#### Example 1: Choice = Date

Only the entry in (start) is relevant:

- (start) date = \*,01.01.09

Result: January 1, 2009 is an exception date.

- (Start) date = Mo,\*.\*.00

Every Monday is an exception day.

- (Start) date = \*,\*.Evn.00

The days for the entire month are exception day for each even month (February, April, June, August, etc.).

#### Example 2: Choice = Range

The entries in (start) date and end date are relevant:

- (start) date = \*,23.06.09 / end date = \*,12.07.09.

June 23, 2009 through July 12, 2009 are exception days (e.g. vacation).

- (start) date = \*,23.12.00 / end date = \*,31.12.00.

December 23 through 31 are exceptions for each year. The entry end date = \*,01.01.00 does not work here, since January 1 is before December 23.

- (start) date = \*,23.12.09 / end date = \*,01.01.10.

23. December 23, 2009 through January 1, 2010 are exception days.

- (Start) date = \*,\*.\*.00 / -End date = \*,\*.\*.00

**Attention!** This entry is always enabled! The plant is continuously on exception or off.

**Example 3: Choice = Weekday**

The entries for week day are relevant.

- Week day = \*,Fr,\*

Every Friday is an exception day.

- Week day = \*,Fr,Evn

Each Friday in even months (February, April, June, August, etc.) is an exception day.

- Week day = \*,\*,\*

**Attention!** This settings always enables “calendar exception” or “calendar off” days.

**15. Status/Settings**

This menu allows the user to display the actual status and change settings for all the devices available in the AHU. Depending on AHU configuration some menu item may be available or not.



**NOTE!** This menu item is only visible with service password entered.

HMI Path: Main Menu -> Status / Settings

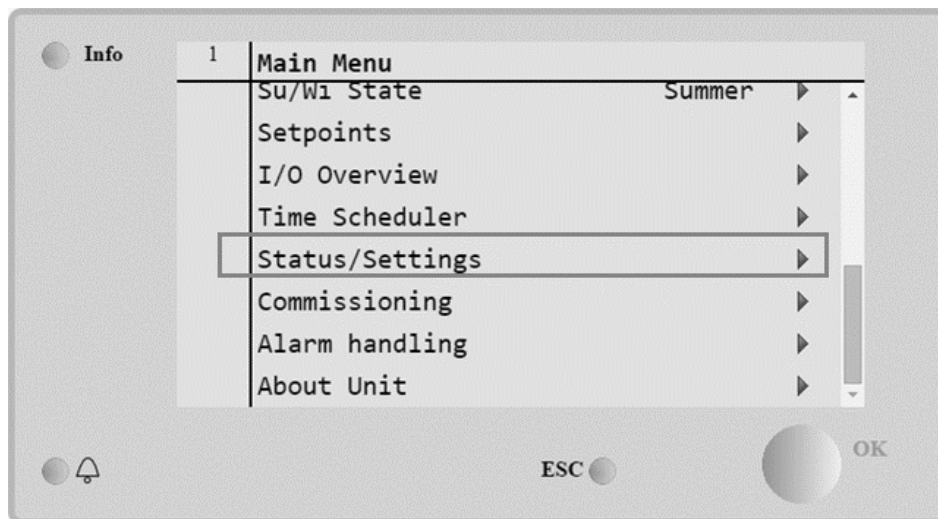

Menu item	Description
<b>AHU Device Monitor</b>	Monitor the actual status and load percentage of all devices installed in the AHU (Dampers, Heat Recovery, Cooling/Heating coils, etc...).
<b>Temperature Control</b>	Contains the specific parameters for general thermoregulation control. Refer to <b>Temperature Control (Section 15.1)</b> for more details.
<b>Air Quality Control*</b>	Contains all parameters for air quality control monitoring and parameter settings. Refer to <b>Air Quality Control (Section 15.2)</b> for more details.
<b>Humidity Control*</b>	Contains all parameters for humidity control monitoring and settings, for both humidification and dehumidification.

Menu item	Description
	Refer to <b>Humidity Control (Section 15.3)</b> for more details.
<b>Fans</b>	Contains all parameters for fans control monitoring and related functions. Refer to <b>Fans Control (Section 15.4)</b> for more details.
<b>Dampers*</b>	Contains all parameters for dampers control monitoring and settings, for both fresh air and mixing (if installed). Refer to <b>Dampers Control (Section 15.5)</b> for more details.
<b>Recovery*</b>	Contains all parameters for the heat recovery device control monitoring and settings. Refer to <b>Heat Recovery Control (Section 15.6)</b> for more details.
<b>Cooling*</b>	Contains all parameters for water and generic direct expansion (DX) cooling coils monitoring and settings. Refer to <b>Cooling Coil Control (Section 15.7)</b> for more details.
<b>Heating*</b>	Contains all parameters for water and generic direct expansion (DX) heating coils monitoring and settings. Refer to <b>Heating Coil Control (Section 15.8)</b> for more details.
<b>Pumps*</b>	Contains all parameters for water pumps monitoring and settings. Refer to <b>Pumps Control (Section 15.9)</b> for more details.
<b>ERQ*</b>	Contains all parameters for ERQ devices monitoring and settings. Refer to <b>ERQ Control (Section 15.10)</b> for more details.
<b>Electrical Htg*</b>	Contains all parameters for post-heating control monitoring and related functions (Electric coil). Refer to <b>Post-Heating Electrical Control (Section 15.11)</b> for more details.
<b>Pre-Htg Electrical*</b>	Contains all parameters for pre-heating control monitoring and related functions (Electric coil). Refer to <b>Pre-Heating Electrical Control (Section 15.12)</b> for more details.
<b>Pre-Heating Water*</b>	Contains all parameters for pre-heating control monitoring and related functions (Water coil). Refer to <b>Pre-Heating Water Coil Control (Section 15.13)</b> for more details.
<b>Sensor Settings</b>	Check the status of all sensor installed and set an offset correction on sensors readings if needed.
<b>Occupancy Time</b>	Set the time value for which the occupancy function is active. This function will take effect only if the AHU is provided with a room unit device. Refer to <b>Appendix A - Room Unit Module</b> for more details.

*\*Different menu items will be visible depending on AHU configuration.*

## 15.1 Temperature Control

This menu contains the parameters for general thermoregulation control.

*HMI Path: Main Menu -> Status / Settings -> Temperature Control*

Parameter	Default	Range	Description
<b>Active Setpoint</b>	-	-	Display the actual temperature setpoint used for thermoregulation control.
<b>Actual Ctrl Tmp</b>	-	-	Display the actual controlled temperature value.
<b>Su/Wi state</b>	-	-	Display the actual AHU summer/winter state.
<b>Setpoints</b>	-	-	Contains all AHU temperature setpoints. Refer to <b>Setpoint</b> page menu ( <b>Section 12</b> ) for more details.
<b>Temperatures</b>	-	-	Contains all AHU temperature readings.
<b>Gen Deadzone</b>	1 °C	0.5 - 10 °C	Deadband value between temperature setpoint and actual controlled temperature for thermoregulation logics activation.
<b>Max Supply Tmp</b>	40 °C	20 - 80 °C	Maximum supply temperature value above which the control starts to limit the load of installed heating coils.
<b>Min Supply Tmp</b>	17 °C	0 - 30 °C	Minimum supply temperature value below which the control starts to limit the load of installed cooling coils.

## 15.2 Air Quality Control





This menu contains all parameters for air quality control monitoring and parameter settings. This function increase the fan setpoint value by "**Max forcing**" value in order to reach the air quality setpoint selected.



**NOTE!** This menu is not visible if no air quality control function is enabled.

*HMI Path: Main Menu -> Status / Settings -> Air Quality Control*

Parameters	Default	Range	Description
<b>CO2 Conc.</b>	-	-	Display the CO <sub>2</sub> concentration measured.
<b>Setpoint</b>	800 ppm	0 - 3000 ppm	Set the air quality control setpoint.
<b>Supply fan</b>			
<b>Max forcing</b>	- 0 % - 0 Pa - 0 m <sup>3</sup> /h	- 0..100 % - 0..9900 Pa - 0..139900	Set the maximum compensation value that will be added to fan setpoint when air quality control function is active.

Parameters	Default	Range	Description
		m <sup>3</sup> /h	 <b>NOTE!</b> This value strictly depends on AHU application site and desired setpoint, so it must be changed accordingly from default value if it is needed to activate the compensation function.   Measure unit depends on fan control mode selected.
<b>Actual Comp</b>	-	0 - 100 %	Display the actual fan compensation action percentage: <ul style="list-style-type: none"> <li>- 0% -&gt; No fan SP increasing;</li> <li>- 50% -&gt; Fan SP increased by "<b>Max forcing</b>"/2;</li> <li>- 100% -&gt; Fan SP increased by "<b>Max forcing</b>".</li> </ul>
<b>Return fan</b>			
<b>Max forcing</b>	- 0 % - 0 Pa - 0 m <sup>3</sup> /h	- 0..100 % - 0..9900 Pa - 0..139900 m <sup>3</sup> /h	Set the maximum compensation value that will be added to fan setpoint when air quality control function is active.   <b>NOTE!</b> This value strictly depends on AHU application site and desired setpoint, so it must be changed accordingly from default value if it is needed to activate the compensation function.   Measure unit depends on fan control mode selected.
<b>Actual Comp</b>	-	0 - 100 %	Display the actual fan compensation action percentage: <ul style="list-style-type: none"> <li>- 0% -&gt; No fan SP increasing;</li> <li>- 50% -&gt; Fan SP increased by "<b>Max forcing</b>"/2;</li> <li>- 100% -&gt; Fan SP increased by "<b>Max forcing</b>" value.</li> </ul>

### 15.3 Humidity Control

This menu contains all parameters for both humidification and dehumidification control monitoring and settings.



**NOTE!** This menu is not visible if no humidity control function is enabled.

HMI Path: Main Menu -> Status / Settings -> Humidity Control

Parameters	Default	Range	Description
<b>Relative Hum</b>	-	-	Display the value coming from the humidity sensor readings.
<b>Dehum Setpoint*</b>	60 %rH	0 - 100 %rH	Set the dehumidification control setpoint.



Parameters	Default	Range	Description
<b>Dehum*</b>	-	- Off - Active	Display the actual state of the dehumidification control logic.
<b>Win Dehum En*</b>	No	- No - Yes	Specify if the dehumidification control must be activated also during " <b>Winter</b> " AHU mode.
<b>Hum Setpoint*</b>	40 %rH	0 - 100 %rH	Set the humidification control setpoint.
<b>Humidifier*</b>	-	0 - 100%	Display the actual controller load command for the humidification device.
<b>Adiabatic Recovery*</b>	-	- Off - On	Display the actual state of the adiabatic recovery function.
<b>Sum Hum En*</b>	No	- No - Yes	Specify if the humidification control must be activated also during " <b>Summer</b> " AHU mode.



*\*Different menu items will be visible depending on AHU configuration.*

## 15.4 Fans Control



This menu contains all parameters and settings for fans control monitoring and related functions.

HMI Path: Main Menu -> Status / Settings -> Fans

Parameters	Default	Range	Description
<b>Setpoints</b>	-	-	Contains all AHU setpoints related to fan control. Refer to <b>Setpoint</b> page menu ( <b>Section 12</b> ) for more details.
<b>Fan Data*</b>	-	-	Contains additional supply/return fans data.  <i><u>This menu item is available only for Modular AHU.</u></i>
<b>Fan Compensation</b>	-	- None - Temp. - Co2	Display the actual compensation function selected during AHU commissioning for fans control logic.  - <b>None</b> : no fan compensation function selected; - <b>Temperature</b> : temperature compensation function selected. This function starts to decrease the fan setpoint value selected by " <b>Max forcing</b> " value only if both heat recovery and mixing damper devices are at full load, in order to increase the thermal exchange between airflow and heating/cooling coils and reach the desired temperature setpoint.  - <b>Co2</b> : air quality compensation function selected. This function increase the fan setpoint value selected by

Parameters	Default	Range	Description
			<p><b>“Max forcing”</b> value in order to reach the air quality setpoint selected.</p> <p>Refer to <b>Air Quality Control (Section 15.2)</b> for more details.</p>
<b>Supply fan</b>			
<b>Active Setpoint</b>	-	-	Display the actual supply fan setpoint that is used in the control logic (this value represents the sum of all functions that affect the supply fan setpoint).
<b>Supply Pressure*</b>	-	-	Display the value read from the supply fan pressure sensor.
<b>Supply Air Flow*</b>	-	-	Display the value read from the supply fan air flow sensor.
<b>State</b>	-	- Off - On	Display the actual fan state.
<b>Speed</b>	-	0 - 100 %	Display the actual fan speed.
<b>Delay On Tm</b>	60 s	0 - 36000 s	Set the time delay between fresh/exhaust dampers opening and fan activation.
<b>Over Run Tm*</b>	180 s	0 - 36000 s	<p>Set the time period after AHU turn off for supply fan post-ventilation, in order to cool down the electric coils.</p> <p><u><i>This setpoint is available only if an electric coil is installed.</i></u></p> <p> <b>The controller will activate the post-ventilation function only if the electric coil has been turned on during AHU operation.</b></p>
<b>Max forcing*</b>	- 0 % - 0 Pa - 0 m <sup>3</sup> /h	- 0..100 % - 0..9900 Pa - 0..139900 m <sup>3</sup> /h	<p>Set the maximum compensation value that will be added (Co2 compensation) or subtracted (Temp. compensation) to fan setpoint when fan compensation function is active. Refer to <b>“Fan Compensation”</b> parameter for additional details.</p> <p><u><i>This value is available only if a fan compensation function has been selected in configuration.</i></u></p> <p> <b>NOTE! This value strictly depends on AHU application site and desired setpoint, so it must be changed accordingly from default value if it is needed to activate the compensation function.</b></p> <p> <b>Measure unit depends on fan control mode selected.</b></p>

Parameters	Default	Range	Description
<b>Actual Comp*</b>	-	0 - 100 %	Display the actual fan compensation action percentage: <ul style="list-style-type: none"> <li>- 0% -&gt; No fan SP inc/dec;</li> <li>- 100% -&gt; Fan SP inc/dec by "<b>Max forcing</b>" value.</li> </ul> Refer to " <b>Fan Compensation</b> " parameter for additional details.  <u><i>This value is available only if a fan compensation function has been selected in configuration.</i></u>
<b>Max Setpnt Devtn*</b>	30 %	0 - 100 %	Set the percentage deviation between fan setpoint and sensor reading above which the controller generates a warning, if this condition is verified for more than " <b>Setpnt Devtn On Tm</b> " value.  <u><i>This setpoint is available only if fan deviation alarm function has been enabled in configuration.</i></u>
<b>Setpnt Devtn On Tm*</b>	30 min	0 - 1000 m	Set the time period after which the controller generates a warning if " <b>Max Setpnt Devtn</b> " condition is verified.  <u><i>This setpoint is available only if fan deviation alarm function has been enabled in configuration.</i></u>
<b>Defrost Setpnt*</b>	- 80 % Pa m <sup>3</sup> /h	- 0..100 % - 0..5500 Pa - 0..139900 m <sup>3</sup> /h	Set fan setpoint in case of ERQ defrost state.  <u><i>This setpoint is available only if fan-defrost limitation control has been enabled in configuration.</i></u>
<b>Return fan</b>			
<b>Active Setpoint</b>	-	-	Display the actual return fan setpoint that is used in the control logic (this value represents the sum of all functions that affect the return fan setpoint).
<b>Return Pressure*</b>	-	-	Display the value read from the return fan pressure sensor.
<b>Return Air Flow*</b>	-	-	Display the value read from the return fan air flow sensor.
<b>State</b>	-	- Off - On	Display the actual fan state.
<b>Speed</b>	-	0 - 100 %	Display the actual fan speed.
<b>Delay On Tm</b>	60 s	0 - 36000 s	Set the time delay between fresh/exhaust dampers opening and fan activation.
<b>Max forcing*</b>	- 0 % - 0 Pa - 0 m <sup>3</sup> /h	- 0..100 % - 0..9900 Pa - 0..139900	Set the maximum compensation value that will be added (Co2 compensation) or subtracted (Temp. compensation) to fan setpoint when fan compensation function is active.

Parameters	Default	Range	Description
		m <sup>3</sup> /h	<p>Refer to "<b>Fan Compensation</b>" parameter for additional details.</p> <p><u>This value is available only if a fan compensation function has been selected.</u></p> <p> <b>NOTE!</b> This value strictly depends on AHU application site and desired setpoint, so it must be changed accordingly from default value if it is needed to activate the compensation function.</p> <p> Measure unit depends on fan control mode selected.</p>
<b>Actual Comp*</b>	-	0 - 100 %	<p>Display the actual fan compensation action percentage:</p> <ul style="list-style-type: none"> <li>- 0% -&gt; No fan SP inc/dec;</li> <li>- 100% -&gt; Fan SP inc/dec by "<b>Max forcing</b>" value.</li> </ul> <p>Refer to "<b>Fan Compensation</b>" parameter for additional details.</p> <p><u>This value is available only if a fan compensation function has been selected.</u></p>
<b>Max Setpnt Devtn*</b>	30 %	0 - 100 %	<p>Set the percentage deviation between fan setpoint and sensor reading above which the controller generates a warning, if this condition is verified for more than "<b>Setpnt Devtn On Tm</b>" value.</p> <p><u>This setpoint is available only if fan deviation alarm function has been enabled.</u></p>
<b>Setpnt Devtn On Tm*</b>	30 min	0 - 1000 m	<p>Set the time period after which the controller generates a warning if "<b>Max Setpnt Devtn</b>" condition is verified.</p> <p><u>This setpoint is available only if fan deviation alarm function has been enabled.</u></p>
<b>Defrost Setpnt*</b>	- 80 % Pa m <sup>3</sup> /h	- 0..100 % - 0..5500 Pa - 0..139900 m <sup>3</sup> /h	<p>Set fan setpoint in case of ERQ defrost state.</p> <p><u>This setpoint is available only if fan-defrost limitation control has been enabled.</u></p>
<b>Fan fire stpnt*</b>	80 %	0 - 100 %	<p>Set fans load when a fire alarm is detected.</p> <p><u>This setpoint is available only if the fire alarm function has been enabled.</u></p>

Parameters	Default	Range	Description
<b>Fan fire mode*</b>	Stop	- Stop - Run Sply - Run Exh - Run both	Specify fans state in case of fire alarm. - <b>Stop</b> : stops both fan; - <b>Run Supply</b> : only supply fan will be in on state; - <b>Run Exhaust</b> : only return fan will be in on state; - <b>Run Supply</b> : both fan will be in on state.  <u><i>This setpoint is available only if the fire alarm function has been enabled.</i></u>
<b>Fast Htg/Clg*</b>	-	-	Contains all parameters for configuring the fast heating/cooling function. Refer to <b>Fast Heating/Cooling (Section 15.4.1)</b> for more details.  <u><i>This menu item is available only if the fast heating/cooling function has been enabled.</i></u>

*\*Different menu items will be visible depending on AHU configuration.*

#### 15.4.1 Fast Heating/Cooling

This function is used to quickly bring the ambient temperature at the setpoint value during AHU startup. It maintains an high value of the supply fan setpoint until the temperature reaches the target value; after that, the fan speed is decreased linearly until it reaches the normal operation fan setpoint.



**NOTE!** *This function can be activated only if the AHU is a water type, both heating and cooling, and the temperature controlled is the return or room temperature.*

In the following table are reported all parameters available in the interface to personalize the behavior of this function:

Parameter	Default	Range	Description
<b>Spl-Fan SP Incr</b>	25%	0 - 50%	This parameter indicates the value added to the supply fan setpoint (in % of normal setpoint) during fast heating/cooling.
<b>Strt Tmp Err</b>	5 °C	0 - 30 °C	The fast heating/cooling function is activated only if at the startup of the AHU the difference between the actual temperature setpoint and the controlled temperature is higher than this parameter.
<b>Off Tmp Err</b>	1 °C	0 - 30 °C	When the difference between the actual temperature setpoint and the controlled temperature become less than this parameter, the fast heating/cooling function starts to decrease the supply fan speed.
<b>Off Ramp Time</b>	120 sec	0 - 1200 sec	This parameter sets the time used by the fast heating/cooling function to decrease the supply fan setpoint to normal setpoint.

## 15.5 Dampers Control

This menu contains all parameters for dampers control monitoring and settings, for both fresh air and mixing dampers (if installed).

HMI Path: Main Menu -> Status / Settings -> Dampers

Parameters	Default	Range	Description
<b>Fresh Air Dmp</b>			
<b>Command</b>	-	- Off - On	Display the actual controller command state for the fresh air dampers.
<b>Off delay</b>	10 s	0 - 36000 s	Specify the time delay between an AHU turn off command and fresh air dampers closing.
<b>Mixing Dmp</b>			
<b>Mix dmpr out*</b>	-	0 - 100 %	Display the actual mixing damper load percentage.  - Modular AHU: 0% -> Full Close 100% -> Full Open  - Professional AHU: 0% -> Full Open 100% -> Full Close
<b>Min fresh air*</b>	20 %	0 - 100 %	Set the minimum fresh air damper opening percentage when the mixing damper is installed.
<b>Delta*</b>	2 %	0.5 - 30 %	Set the percentage of opening/closing steps given to the mixing damper at every " <b>Control Rate</b> " period.
<b>Control Rate*</b>	5 s	0 - 120 s	Set the time period at which the control rate step " <b>Delta</b> " is given to the mixing damper.
<b>Reference Tmp*</b>	Return	- Return - Room**	Specify the temperature used for mixing damper thermoregulation control logic. <i>** Selectable only if a Room Unit device is installed.</i>

\* These menu items are available only if the Mixing damper is installed.

## 15.6 Heat Recovery Control

This menu contains all parameters for the heat recovery device control monitoring and settings.



**NOTE!** This menu is not visible if it is not installed any heat recovery device in the AHU.

HMI Path: Main Menu -> Status / Settings -> Recovery

Parameters	Default	Range	Description
Operation Manual 46			Air Handling Unit D-EOMAH00001-16EN

Parameters	Default	Range	Description
<b>Command</b>	-	- Off - On	Display the actual controller command state for heat recovery device.
<b>Hrec output*</b>	-	0 - 100 %	Display the actual heat recovery device load percentage.
<b>Delta*</b>	2 %	0.5 - 30 %	Set the percentage of increase/decrease load steps given to the heat recovery device at every " <b>Control Rate</b> " period.
<b>Control Rate*</b>	5 s	0 - 120 s	Set the time period at which the control rate step " <b>Delta</b> " is given to the heat recovery device.
<b>Reference Tmp*</b>	Return	- Return - Room**	Specify the temperature used for heat recovery device thermoregulation control logic. <b>** Selectable only if a Room Unit device is installed.</b>

\* These menu items are available only if the control of the Recovery device has been configured as modulating.

## 15.7 Cooling Coil Control

This menu contains all parameters for water and generic direct expansion (DX) cooling coils monitoring and settings.



**NOTE!** This menu is not visible if there are no water or DX cooling coils.

HMI Path: Main Menu -> Status / Settings -> Cooling

Parameters	Default	Range	Description
<b>Control Out</b>	-	0 - 100%	Display the actual controller load command for the cooling coil. - Water coil -> this value represents the opening percentage of the valve; - DX coils -> this value represents the internal control reference used to activate the DX steps (see parameters below for additional details).
<b>DX steps stpt</b>			
<b>Min off time*</b>	120 s	5 - 600 s	Set the delay time for the activation of the DX coils steps.
<b>Start stage 1*</b>	20 %	0 - 100 %	Specify the " <b>Control Out</b> " percentage at which the DX step 1 will be activated.
<b>Start stage 2*</b>	40 %	0 - 100 %	Specify the " <b>Control Out</b> " percentage at which the DX step 2 will be activated.
<b>Start stage 3*</b>	80 %	0 - 100 %	Specify the " <b>Control Out</b> " percentage at which the DX step 3 will be activated.

Parameters	Default	Range	Description
<b>Stage hys off*</b>	10 %	1 - 100 %	Specify the turn off hysteresis of DX steps. Example:  "Stage hys off" = 10% & "Start stage 2" = 40% -> DX step 2 turn off at "Control Out" = 30%
<b>Min Temp Lim</b>	-	- Passive - Active	Display the actual status of the minimum supply temperature limitation logic.   <b>The supply temperature limitation logic is always enabled by default.</b>

\* These menu items are available only if a direct expansion device has been selected as cooling coil.

## 15.8 Heating Coil Control

This menu contains all parameters for water and generic direct expansion (DX) heating coils monitoring and settings.



**NOTE!** This menu is not visible if there are no water or DX heating coils.

HMI Path: Main Menu -> Status / Settings -> Heating

Parameters	Default	Range	Description
<b>Control Out</b>	-	0 - 100%	Display the actual controller load command for the heating coil. - Water coil -> this value represents the opening percentage of the valve; - DX coils -> this value represents the internal control reference used to activate the DX steps (see parameters below for additional details).
<b>DX steps stpt</b>			
<b>Start stage 1*</b>	20 %	0 - 100 %	Specify the "Control Out" percentage at which the DX step 1 will be activated.
<b>Start stage 2*</b>	40 %	0 - 100 %	Specify the "Control Out" percentage at which the DX step 2 will be activated.
<b>Start stage 3*</b>	80 %	0 - 100 %	Specify the "Control Out" percentage at which the DX step 3 will be activated.
<b>Stage hys off*</b>	10 %	1 - 100 %	Specify the turn off hysteresis of DX steps. Following an example:  "Stage hys off" = 10% & "Start stage 2" = 40% -> DX step 2 turn off at "Control Out" = 30%
<b>Frost sp</b>	100 %	50 - 100 %	Specify the valve opening percentage in case of frost switch alarm.



Parameters	Default	Range	Description
			<i><u>This menu item is available only if the frost switch has been configured.</u></i>
<b>Frost Off Delay</b>	5 min	3 - 30 min	Specify the delay time between frost switch mechanical deactivation and corresponding alarm auto-reset.  <i><u>This menu item is available only if the frost switch has been configured.</u></i>
<b>ERQ/Wtr priority</b>			
<b>Switch Tmp</b>	10 °C	-20..40 °C	When the ERQ and water coil priority is set to Auto, the activation sequence is automatically determined from the comparison between " <b>Switch Tmp</b> " and the outside air temperature: T <sub>out</sub> > " <b>Switch Tmp</b> " -> ERQ first T <sub>out</sub> < " <b>Switch Tmp</b> " -> Water first  <i><u>This menu item is available only if the ERQ/Wtr priority has been configured as Auto</u></i>
<b>Max Temp Lim</b>	-	- Passive - Active	Display the actual status of the maximum supply temperature limitation logic.   <i><b>The supply temperature limitation logic is always enabled by default.</b></i>

*\* These menu items are available only if a direct expansion device has been selected as heating coil.*

## 15.9 Pumps Control

This menu contains all parameters for water pumps monitoring and settings.



**NOTE!** *This menu is not visible if there are no pumps installed in the AHU.*

HMI Path: Main Menu -> Status / Settings -> Pumps

Parameters	Default	Range	Description
<b>Cooling pump</b>			
<b>Cooling pump*</b>	-	- Off - On	Display the actual controller command state for the cooling pump.
<b>Min run time*</b>	180 s	0 - 36000 s	Specify the time delay between an AHU turn off command and cooling pump off command.
<b>Heating pump</b>			
<b>Heating pump*</b>	-	- Off - On	Display the actual controller command state for the heating pump.

Parameters	Default	Range	Description
<b>Min run time*</b>	180 s	0 - 36000 s	Specify the time delay between an AHU turn off command and heating pump off command.

*\*Different menu items will be visible depending on pump type configuration.*

## 15.10 ERQ Control

This menu contains all parameters for ERQ devices monitoring and settings.



**NOTE!** This menu is not visible if there are no ERQ installed in the AHU.





HMI Path: Main Menu -> Status / Settings -> ERQ





### 15.10.1 ERQ Status

Parameters	Default	Range	Description
<b>State</b>			
<b>ERQ #1</b>	-	- Not Ready - Ready	Display the actual state of ERQ 1
...			
<b>ERQ #4</b>	-	- Not Ready - Ready	Display the actual state of ERQ 4
<b>ERQ current operation</b>			
<b>ERQ #1</b>	-	- Off - On - Defrost	Display the actual operating mode of ERQ 1
...			
<b>ERQ #4</b>	-	- Off - On - Defrost	Display the actual operating mode of ERQ 4
<b>Time to Ready</b>			
<b>ERQ #1</b>	-		Display the time before the ERQ 1 becomes Ready again
...			
<b>ERQ #4</b>	-		Display the time before the ERQ 4 becomes Ready again
<b>Load</b>			
<b>ERQ #1</b>	-	0 - 100 %	Display the actual load percentage of ERQ 1
...			
<b>ERQ #4</b>	-	0 - 100 %	Display the actual load percentage of ERQ 4
<b>Signal 0-10V</b>			
<b>ERQ #1</b>	-	0 - 10V	Display the actual controller voltage output for ERQ 1

Parameters	Default	Range	Description
...			
<b>ERQ #4</b>	-	0 - 10V	Display the actual controller voltage output for ERQ 4

### 15.10.2 ERQ Settings

Parameters	Default	Range	Description
<b>Startup DT</b>	2 °C	1 - 10 °C	<p>Set the temperature threshold between the setpoint and the actual controlled temperature for the startup of a new ERQ (this value represent the deadzone for the activation of the ERQs).</p> <p>In addition, this condition must be verified for at least "<b>Startup Time</b>".</p> <p> <b>NOTE!</b> This value depends on the temperature that is being controlled. If the controlled temperature is the supply one, it is advisable to not set this value lower than default, in order to avoid undesired control oscillation.</p> <p> The ERQs activation sequence follows a control logic that evaluates the actual running hours and the number of starts for each ERQ, in order to equalize their workload. This means that the sequence does not necessarily follows the ERQs sequence number (1 to 4).</p>
<b>Startup Time</b>	60 sec	0 - 3600 s	Set the time period for which the ERQ activation condition " <b>Startup DT</b> " must be verified for the startup of the ERQs.
<b>Interval Time Startup</b>	360 sec	0 - 3600 s	Interval time between the startup of one ERQ and the next.
<b>Shutdown DT</b>	3.5 °C	1 - 10 °C	<p>Set the temperature threshold between the setpoint and the actual controlled temperature for the shutdown of an ERQ (this value represent the deadzone for the deactivation of the ERQs).</p> <p>In addition, this condition must be verified for at least "<b>Shutdown Time</b>".</p> <p> <b>NOTE!</b> This value depends on the temperature that is being controlled. If the controlled temperature is the supply one, it is advisable to not set this value lower than default, in order to avoid undesired control oscillation.</p> <p> The ERQs shutdown sequence follows a control logic that evaluates the actual running hours and the number of starts for each ERQ, in order to equalize their workload. This means that the</p>

Parameters	Default	Range	Description
			<i>sequence does not necessarily follows the ERQs sequence number (4 to 1).</i>
<b>Shutdown Time</b>	360 sec	0 - 3600 s	Set the time period for which the ERQ deactivation condition " <b>Shutdown DT</b> " must be verified for the shutdown of the ERQs.
<b>Min Load Limit</b>	0 %	0 -100 %	Minimum load percentage that the last ERQ active must reaches before it is turned off   <b>NOTE!</b> <i>The last ERQ follows both conditions "Shutdown DT" &amp; "Min Load Limit".</i>
<b>Interval Time Shutdown</b>	360 sec	0 - 3600 s	Interval time between the shutdown of one ERQ and the next.
<b>Lower Limit Te</b>	0 °C	-64..64 °C	Lower limit for the Evaporating temperature.   <b>NOTE!</b> <i>This parameter must match the one that is set on Daikin Controlbox (Mode 51, Settings 1). If one is changed, the other must be set accordingly.</i>
<b>Upper Limit Te</b>	15 °C	-64..64 °C	Upper limit for the Evaporating temperature.   <b>NOTE!</b> <i>This parameter must match the one that is set on Daikin Controlbox (Mode 51, Settings 1). If one is changed, the other must be set accordingly.</i>
<b>Lower Limit Tc</b>	35 °C	-64..64 °C	Lower limit for the Condensing temperature.   <b>NOTE!</b> <i>This parameter must match the one that is set on Daikin Controlbox (Mode 51, Settings 0). If one is changed, the other must be set accordingly.</i>
<b>Upper Limit Tc</b>	49 °C	-64..64 °C	Upper limit for the Condensing temperature.   <b>NOTE!</b> <i>This parameter must match the one that is set on Daikin Controlbox (Mode 51, Settings 0). If one is changed, the other must be set accordingly.</i>
<b>Time Off</b>	60 sec	0 - 3600 s	Time between two ERQ load control pulses.
<b>Threshold 1</b>	40 %	0 -100 %	Minimum load that must reaches the first ERQ before it is turned on the second ERQ.
<b>Threshold 2</b>	40 %	0 -100 %	Minimum load that must reaches the second ERQ before

Parameters	Default	Range	Description
			it is turned on the third ERQ.
<b>Threshold 3</b>	40 %	0 -100 %	Minimum load that must reaches the third ERQ before it is turned on the fourth ERQ.

### 15.11 Post-Heating Electrical Control

This menu contains all parameters for electrical post-heating control monitoring and settings.



**NOTE!** This menu is not visible if there is not an electrical post-heater installed in the AHU.

HMI Path: Main Menu -> Status / Settings -> Electrical Heat

Parameters	Default	Range	Description
<b>Electrical Htg*</b>	-	- Off - Step 1 - Step 2	Display the actual controller command for the electrical heating coil.
<b>Control Out</b>	-	0 - 100%	Display the actual controller load command for the electrical heating coil. - Modulating coil -> this value represents the load percentage of the electrical heating coil; - Step coil -> this value represents the internal control reference used to activate the electrical heating stages (see parameters below for additional details).
<b>Start stage 1*</b>	20 %	0 - 100 %	Specify the " <b>Control Out</b> " percentage at which the electrical heating step 1 will be activated.
<b>Start stage 2*</b>	40 %	0 - 100 %	Specify the " <b>Control Out</b> " percentage at which the electrical heating step 2 will be activated.
<b>Stage hys off*</b>	10 %	1 - 100 %	Specify the turn off hysteresis of electrical heating steps. Example: <b>"Stage hys off"</b> = 10% & <b>"Start stage 2"</b> = 40% -> Electrical heating step 2 turn off at <b>"Control Out"</b> = 30%
<b>Max Temp Lim</b>		- Passive - Active	Display the actual status of the maximum supply temperature limitation logic.  <div style="display: flex; align-items: center;"> <p><b>The supply temperature limitation logic is always enabled by default.</b></p> </div>

\* These menu items are available only if the device is a step electrical post-heater.

### 15.12 Pre-Heating Electrical Control

This menu contains all parameters for electrical pre-heating control monitoring and settings.



**NOTE!** This menu is not visible if there is not an electrical pre-heater installed in the AHU.

HMI Path: Main Menu -> Status / Settings -> Pre-Htg Electrical

Parameters	Default	Range	Description
<b>Pre-Heating Temperature</b>	-	-	Display the pre-heating temperature sensor reading.
<b>Setpoint</b>	10 °C	0 - 30 °C	Set the pre-heating temperature setpoint.
<b>Pre Htg Elect</b>	-	- Off - Step 1 - Step 2	Display the actual controller command for the electrical pre-heating coil.
<b>Control Out</b>	-	0 - 100%	Display the actual controller load command for the electrical pre-heating coil. This value represents the internal control reference used to activate the electrical pre-heating stages (see parameters below for additional details).
<b>Start stage 1</b>	20 %	0 - 100 %	Specify the " <b>Control Out</b> " percentage at which the electrical pre-heating step 1 will be activated.
<b>Start stage 2</b>	40 %	0 - 100 %	Specify the " <b>Control Out</b> " percentage at which the electrical pre-heating step 2 will be activated.
<b>Stage hys off</b>	10 %	1 - 100 %	Specify the turn off hysteresis of electrical pre-heating steps. Example:  " <b>Stage hys off</b> " = 10% & " <b>Start stage 2</b> " = 40% -> Electrical pre-heating step 2 turn off at " <b>Control Out</b> " = 30%
<b>Rec Prot Active</b>	-15 °C	-30..20 °C	Specify the outside temperature threshold below which the pre-heater will be activated in order to prevent the heat recovery device freezing.

### 15.13 Pre-Heating Water Control

This menu contains all parameters for pre-heating water coil control monitoring and settings.



**NOTE!** This menu is not visible if there is not a pre-heater water coil installed in the AHU.

HMI Path: Main Menu -> Status / Settings -> Pre-Htg Water

Parameters	Default	Range	Description
<b>Pre-Heating Temperature</b>	-	-	Display the pre-heating temperature sensor reading.
<b>Setpoint</b>	10 °C	0 - 30 °C	Set the pre-heating temperature setpoint.

Parameters	Default	Range	Description
<b>Control Output</b>	-	0 - 100%	Display the actual controller load command for the electrical pre-heating coil. This value represents the internal control reference used to activate the electrical pre-heating stages (see parameters below for additional details).
<b>Rec Prot Active</b>	-15 °C	-30..20 °C	Specify the outside temperature threshold below which the pre-heater will be activated in order to prevent the heat recovery device freezing.

## 16. Commissioning

This menu allows the user to commission the Daikin AHU by configuring its type, components and functions, as well as other parameters, like supply/return fan type and sensors. It is also used to perform controller output test, monitor sensors raw readings and configure the communication modules parameters.



**ATTENTION!** Any modification in this menu may result in a malfunctioning of the unit. Please contact your local service organization before making any changes.



**NOTE!** This menu item is only visible with service password entered.

HMI Path: Main Menu -> Commissioning

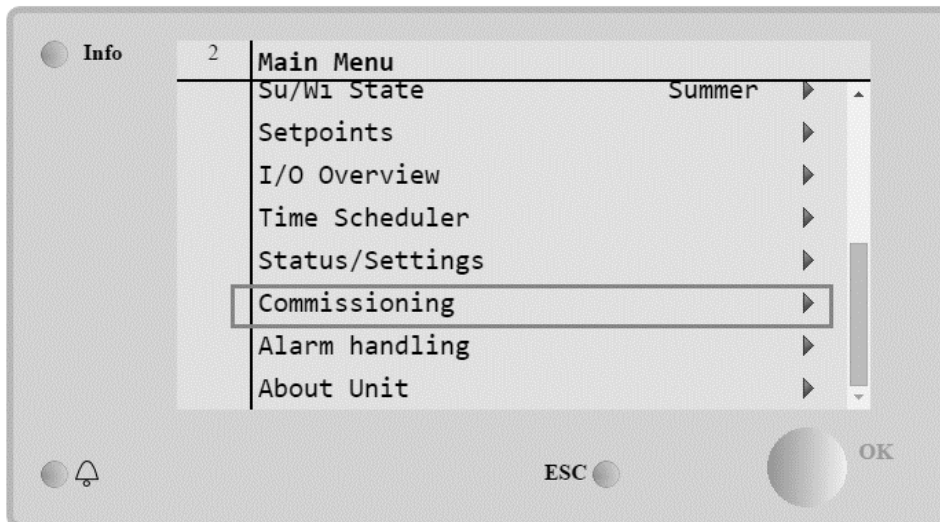



Menu item	Description
<b>AHU Configuration</b>	Contains the AHU commissioning parameters like AHU type, components, functions and fans settings. Refer to <b>AHU Commissioning Manual</b> for more details.
<b>Output test</b>	This menu allows the user to control every analog and digital output

Menu item	Description
	of the controller for testing purposes. These settings are considered only if the unit is in " <b>Test</b> " mode. Refer to <b>Local Switch (Section 10)</b> for more details.
<b>Input raw value</b>	Monitor all sensors readings raw values, like Ohm, Voltage or Ampere. Check these parameters in order to verify if the sensors are defective.
<b>Save / Load</b>	This menu allows to manage the configuration of the AHU by saving/loading the configuration file to/from an external SD memory card, as well as remove the actual configuration and restore the unit to a pre-commissioning state. Refer to <b>Configuration Save &amp; Load (Section 16.1)</b> for more details.
<b>Communication</b>	Contains all parameters to properly configure the BACnet/Modbus communication modules installed. Refer to <b>Communication Modules Configuration (Section 16.2)</b> for more details.
<b>Cloud Connection</b>	Contains the parameters necessary to setup the connection of the AHU to Daikin cloud.
<b>Daylight saving time</b>	Contains the parameters to configure the DayLight Saving time (DLS) function. Refer <b>Daylight saving time (Section 16.3)</b> for more details.

### 16.1 Configuration Save & Load

This menu allows to manage the configuration of the AHU by saving/loading the configuration file to/from an external SD memory card, as well as remove the actual configuration and restore the unit to a pre-commissioning state.

For additional information on how to perform configuration saving & loading please refer to the software updating manual.

Parameter	Range	Description
<b>Conf. save</b>	- Blank - Execute	Save the actual configuration file to an external SD memory card.
<b>Conf. default</b>	- Blank - Execute	Restore the AHU configuration to a pre-commissioning state.  <b>When "Execute" is selected, the controller will reboot.</b>
<b>Conf. load</b>	- Blank - Execute	Load a configuration file from an external SD memory card.  <b>The loading operation will be completed only when the controller displays "Done". After this, a restart is required.</b>
<b>Restart Required!</b>	- Blank - Execute	<b>"Conf. load"</b> function requires a controller reboot in order to make it effective.



## 16.2 Communication Modules Configuration

This sections describes the parameters available on the controller when a communication module is installed.

### 16.2.1 Modbus

When a POL902 is connected to the main controller, the following menu is available on the HMI:

**HMI Path: Main menu → Commissioning → Communication → Comm Modules → 1-Modbus**



**NOTE!** After the connection of POL902 to main controller, the following alarm could occurs: “MdlChgd: Restart Needed”. A simple controller restart will erase the alarm.



**NOTE!** The module has two different ports available but only the top one is programmed and operational.

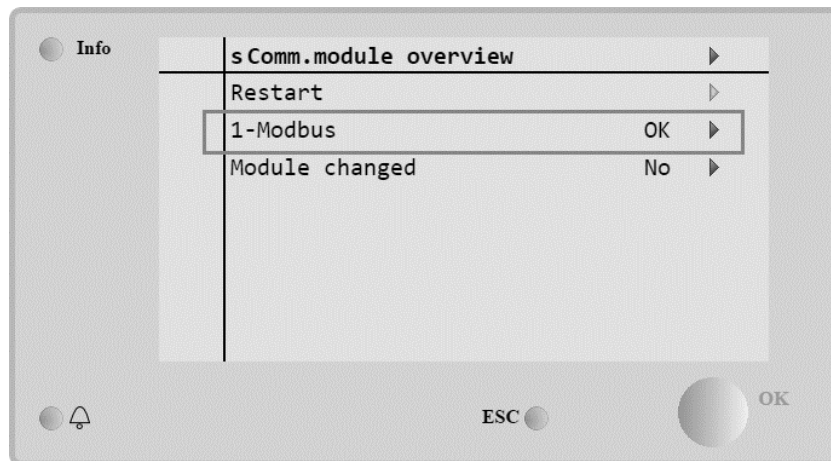

In the following table are reported all parameters available in the communication module configuration page:

Parameter	Default	Range	Description
<b>State</b>	-	-	Display the status of the communication module.
<b>Comm. failure</b>	-	- Passive - Active	Display if there is a communication failure between main controller and communication module.
<b>Channel 1:</b>			
<b>Slave</b>	-	- Passive - Active	Display the status of T1 port.
<b>Slave Address</b>	1	0 - 429496729	Set the slave address of the communication module.

<b>Baud rate</b>	9600	300 - 15200	Set the baud rate of the Modbus communication.
<b>Stop bits</b>	Two	- One - Two	Set the number of stop bits of the Modbus communication.
<b>Parity</b>	None	- Even - Odd - None	Set the parity bit of the Modbus communication.
<b>Response Delay</b>	5 s	0 - 3600 s	Set the response delay of the slave device.
<b>Timeout</b>	-	- Passive - Active	Display if there is a timeout error in the communication with Modbus master.
<b>Termination</b>	Passive	- Passive - Active	Specify if the resistance termination is needed on this slave device for the Modbus network.
<b>General:</b>			
<b>Timeout comm.</b>	3 s	0 - 3600 s	Set the time period before a timeout error in the communication is displayed.
<b>Eng. Unit support</b>	None	- None - Target - Metric - Imperial	Specify the system of measurement used for the Modbus communication module:  - <b>None</b> : no system used; - <b>Target</b> : same as main controller; - <b>Metric</b> : metric system; - <b>Imperial</b> : imperial system.
<b>Software version</b>	-	-	Display the actual software version installed in the communication module.
<b>Device ID</b>	-	-	Display the ID of the communication module.
<b>Module</b>	-	-	Display the communication module type.
<b>Restart Required!</b>	-	- Execute	Restart the controller to save the modification done.   <b>Restart the controller after "Use default" or after any modification of values.</b>
<b>Use default</b>	-	- Passive - Active	Set this parameter to " <b>Active</b> " to restore the default configuration.

### 16.2.2 BACnet-IP

When a POL908 is connected to the main controller, the following menu is available on the HMI:

**HMI Path: Main menu → Commissioning → Communication → Comm Modules → 1-BACnet IP**



**NOTE!** After the connection of POL908 to main controller, the following alarm could occurs: “MdlChgd: Restart Needed”. A simple controller restart will erase the alarm.

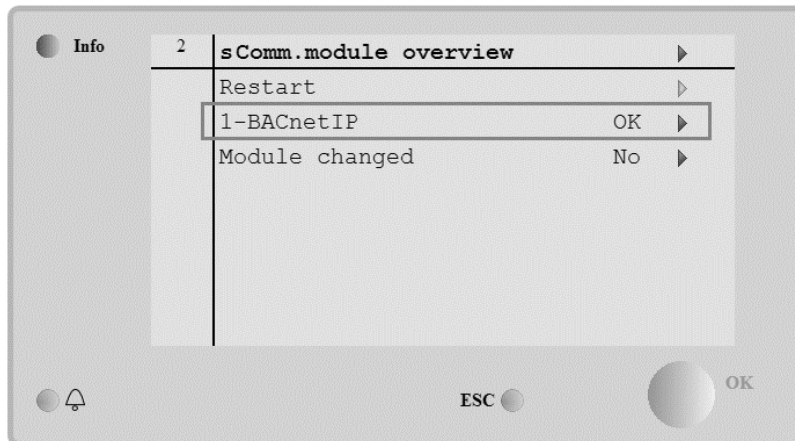

In the following table are reported all parameters available in the communication module configuration page:

Parameter	Default	Range	Description
<b>State</b>	-	-	Display the status of the communication module.
<b>Comm. failure</b>	-	- Passive - Active	Display if there is a communication failure between main controller and communication module.
<b>BACnet:</b>			
<b>Device name</b>	-	-	Name of the slave device in the BACnet network.
<b>Device ID</b>	-	-	ID of the slave device. Represent the ID that is assigned to POL908 in the BACnet network.
<b>Port</b>	-	-	No use.
<b>TCP/IP:</b>			
<b>DHCP</b>	Active	- Passive - Active	Use to enable or disable the DHCP (Dynamic Host Configuration Protocol) option. If DHCP is set to “ <b>Active</b> ” the IP address of the POL908 is assigned by the master of the BACnet network. If DHCP is set to “ <b>Passive</b> ” the IP address of the POL908 is set by the parameter “ <b>Given IP</b> ”.
<b>Actual IP</b>	-	-	Display the actual IP address of the BACnet module.
<b>Actual Mask</b>	-	-	Display the actual Subnet mask of the BACnet module.
<b>Act. Gateway</b>	-	-	Display the actual Gateway address of the BACnet network.
<b>Given IP</b>	-	-	Set the IP address when the DHCP is set to Passive.

<b>Given Mask</b>	-	-	Set the Subnet mask when the DHCP is set to Passive.
<b>Given Gateway</b>	-	-	Set the address of the Gateway when the DHCP is set to Passive.
<b>Write Settings</b>	-	- Passive - Active	Set this parameter to <b>“Active”</b> before restart the controller in order to save the modifications done.
<b>General:</b>			
<b>Software version</b>	-	-	Display the actual software version installed in the communication module.
<b>Device ID</b>	-	-	Display the ID of the communication module.
<b>Module</b>	-	-	Display the communication module type.
<b>Restart Required!</b>	-	- Execute	Restart the controller to save the modification done.   <b>Restart the controller after “Use default” or after any modification of values.</b>
<b>Use default</b>	-	- Passive - Active	Set this parameter to <b>“Active”</b> to restore the default configuration.

### 16.3 Daylight saving time

This page allows to configure the DayLight Saving time (DLS) function.

Parameters	Default	Range	Description
<b>Enable</b>	Yes	- No - Yes	Specify if the DayLight Saving time function is enabled or not.
<b>Active</b>	-	- No - Yes	Display if the DayLight Saving time function is currently active.
<b>Start month</b>	Mar	Jan - Dec	Set DayLight Saving time start month.
<b>Start week day</b>	Su	Mo - Su	Set DayLight Saving time start week day.
<b>Start offset</b>	4	0 - 10	Set DayLight Saving time weekday in the month when the changeover should occur:  0: Fifth to last weekday in the month 1: Fourth to last weekday in the month 2: Third to last weekday in the month 3: Second to last weekday in the month 4: Last weekday in the month 5: Invalid 6: First weekday in the month 7: Second weekday in the month

Parameters	Default	Range	Description
			8: Third weekday in the month 9: Fourth weekday in the month 10: Fifth weekday in the month
<b>Start hour</b>	2 hrs	0 - 23 hrs	Set DayLight Saving time start hour.
<b>Start delay</b>	0 hrs		Set DayLight Saving time changeover delay in hours.
<b>End month</b>	Oct	Jan - Dec	Set DayLight Saving time end month.
<b>End week day</b>	Su	Mo - Su	Set DayLight Saving time end week day.
<b>End offset</b>	4	0 - 10	Set DayLight Saving time weekday in the month when the changeover should occur:  0: Fifth to last weekday in the month 1: Fourth to last weekday in the month 2: Third to last weekday in the month 3: Second to last weekday in the month 4: Last weekday in the month 5: Invalid 6: First weekday in the month 7: Second weekday in the month 8: Third weekday in the month 9: Fourth weekday in the month 10: Fifth weekday in the month
<b>End hour</b>	3 hrs	0 - 23 hrs	Set DayLight Saving time end hour.
<b>End delay</b>	0 hrs		Set DayLight Saving time changeover delay in hours.
<b>UTC-difference</b>	-60 min		Set the difference with UTC.



*On board real time clock settings are maintained thanks to a battery mounted on the controller. Make sure that the battery is replaced regularly each 2 years.*

## 17. Alarm handling

This menu can be used to visualize and manage every alarm occurrence.

*HMI Path: Main Menu -> Alarm handling*

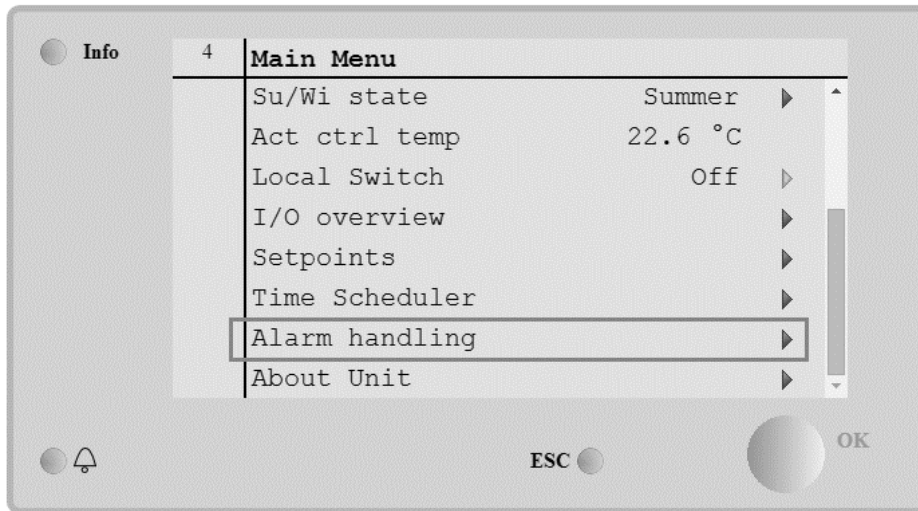

Depending on the severity of the alarm, the AHU can assume two different behaviors:

- **Not Critical Alarm:** the AHU normal functioning is not affected, reporting only on the interface the alarm condition. An example of not critical alarm is the indication of a dirty filter.
- **Critical Alarm:** the AHU switches to OFF state and controls remain locked until the alarm condition is restored. An example of critical alarm is a fan fault.

### 17.1 Alarm restore

When an alarm is displayed on the controller, follow this procedure to go back to the normal functioning:

1. Refer to **“Alarm list” (Section 17.2)** for an explanation of the alarm and for the indication about resolving the alarm condition.
2. When the alarm condition is restored, an alarm acknowledge command is needed on the controller:

*HMI Path: Main menu -> Alarm handling -> Alarm list -> Acknowledge = Execute*

3. If the alarm condition is correctly restored after the **“Execute”** command, the AHU goes back to normal functioning.

## 17.2 Alarm list

Next table shows all alarm strings that appears on screen when an alarm occurs, with the respective causes and solutions list.

Alarm String	Description	Possible causes & solutions		
<b>Outside temp:</b> -no sensor -over range -under range -shortd loop -config err	Error condition on the outside temperature sensor: measured temperature out of the allowable range or error condition on the sensor.	<b>Error</b>	<b>Causes</b>	<b>Solutions</b>
		no sensor	Sensor not connected	Check the wiring connection of the temperature sensor with the controller or (if it is powered) with the electrical power
		over range	Measured value over max limit	If the measured value is wrong replace the sensor
		under range	Measured value under range	If the measured value is wrong replace the sensor
		shortd loop	The sensor could be broken	Disconnect the temperature sensor from the controller and measure the resistance value of the sensor. Refer to the datasheet of the sensor for the resistance nominal value of sensor
config err	The sensor not corresponds to the sensor type set in the software for the specific input of the controller	Check if the sensor is connected to the correct pin of the controller		
<b>Room temp:</b> -no sensor -over range -under range -shortd loop -config err	Error condition on the room air temperature sensor: measured temperature out of the allowable range or error condition on the sensor.	<b>Error</b>	<b>Causes</b>	<b>Solutions</b>
		no sensor	Sensor not connected	Check the wiring connection of the temperature sensor with the controller or (if it is powered) with the electrical power
		over range	Measured value over max limit	If the measured value is wrong replace the sensor
		under range	Measured value under range	If the measured value is wrong replace the sensor
		shortd loop	The sensor could be broken	Disconnect the temperature sensor from the controller and measure the resistance value of the sensor. Refer to the datasheet of the sensor for the nominal resistance.

Alarm String	Description	Possible causes & solutions		
		config err	The sensor not corresponds to the sensor type set in the software for the specific input of the controller	Check if the sensor is connected to the correct pin of the controller
<b>Return temp:</b> -no sensor -over range -under range -shortd loop -config err	Error condition on the return air temperature sensor: measured temperature out of the allowable range or error condition on the sensor.	<b>Error</b>	<b>Causes</b>	<b>Solutions</b>
		no sensor	Sensor not connected	Check the wiring connection of the temperature sensor with the controller or (if it is powered) with the electrical power
		over range	Measured value over max limit	If the measured value is wrong replace the sensor
		under range	Measured value under range	If the measured value is wrong replace the sensor
		shortd loop	The sensor could be broken	Disconnect the temperature sensor from the controller and measure the resistance value of the sensor. Refer to the datasheet of the sensor for the resistance nominal value of sensor
		config err	The sensor not corresponds to the sensor type set in the software for the specific input of the controller	Check if the sensor is connected to the correct pin of the controller
<b>Supply temp:</b> -no sensor -over range -under range -shortd loop -config err	Error condition on the supply air temperature sensor: measured temperature out of the allowable range or error condition on the sensor.	<b>Error</b>	<b>Causes</b>	<b>Solutions</b>
		no sensor	Sensor not connected	Check the wiring connection of the temperature sensor with the controller or (if it is powered) with the electrical power
		over range	Measured value over max limit	If the measured value is wrong replace the sensor
		under range	Measured value under range	If the measured value is wrong replace the sensor



Alarm String	Description	Possible causes & solutions		
		shortd loop	The sensor could be broken	Disconnect the temperature sensor from the controller and measure the resistance value of the sensor. Refer to the datasheet of the sensor for the resistance nominal value of sensor
		config err	The sensor not corresponds to the sensor type set in the software for the specific input of the controller	Check if the sensor is connected to the correct pin of the controller
<b>Pre-Heating temp:</b>  <b>-no sensor</b> <b>-over range</b> <b>-under range</b> <b>-shortd loop</b> <b>-config err</b>	Error condition on the pre-heating air temperature sensor: measured temperature out of the allowable range or error condition on the sensor.	<b>Error</b>	<b>Causes</b>	<b>Solutions</b>
		no sensor	Sensor not connected	Check the wiring connection of the temperature sensor with the controller or (if it is powered) with the electrical power
		over range	Measured value over max limit	If the measured value is wrong replace the sensor
		under range	Measured value under range	If the measured value is wrong replace the sensor
		shortd loop	The sensor could be broken	Disconnect the temperature sensor from the controller and measure the resistance value of the sensor. Refer to the datasheet of the sensor for the resistance nominal value of sensor
		config err	The sensor not corresponds to the sensor type set in the software for the specific input of the controller	Check if the sensor is connected to the correct pin of the controller
<b>Heating Pump: Alarm</b>	Heating pump possible malfunction. This alarm occurs when the water pump communicate to the controller an alarm condition.	<b>Causes</b>		<b>Solutions</b>
		The alarm signal of the water pump is not connected to the controller		Check the wiring connection between the input "Cooling/Heating coil pump alarm" (water coils combined) or "Heating coil pump alarm" (water coils separated or only a heating

Alarm String	Description	Possible causes & solutions	
			water coil present) of the controller and alarm output of the pump
		The pump is in a fault state	- Refer to troubleshooting of the water pump - Check the electrical connection of the pump - Replace the pump if broken
<b>Cooling Pump: Alarm</b>	Cooling pump possible malfunction.  This alarm occurs when the water pump communicate to the controller an alarm condition.	<b>Causes</b>	<b>Solutions</b>
		The alarm signal of the water pump is not connected to the controller	Check the wiring connection between the input "Cooling/Heating coil pump alarm" of the controller and alarm output of the pump
		The pump is in a fault state	- Refer to troubleshooting of the water pump - Check the electrical connection of the pump - Replace the pump if broken
<b>Supply filter: Alarm [Professional]</b>	Supply filter fault. Filter dirty.  This alarm occurs when the differential pressure switch of the filter detects a pressure difference pressure between input and output of the filter.	<b>Causes</b>	<b>Solutions</b>
		The filter is dirty	Change the filter
		The pressure switch is not connected	Check the wiring connection of the pressure switch with the controller.  Check the electrical power of the differential pressure switch
		The pressure switch is broken	Replace the pressure switch
<b>Return filter: Alarm [Professional]</b>	Return filter fault. Filter dirty.  This alarm occurs when the differential pressure switch of the filter detects a pressure difference pressure between input and output of the filter.	<b>Causes</b>	<b>Solutions</b>
		The filter is dirty	Change the filter
		The pressure switch is not connected	- Check the wiring connection of the pressure switch with the controller. - Check the electrical power of the differential pressure switch.
		The pressure switch is broken	Replace the pressure switch

Alarm String	Description	Possible causes & solutions	
<b>Filter: Alarm</b> <i>[Modular]</i>	Supply or Return filter fault. Filter dirty.  This alarm occurs when the differential pressure switch of the filter detects a pressure difference between input and output of the filter.	<b>Causes</b>	<b>Solutions</b>
		The filter is dirty	Change the filter
		The pressure switch is not connected	- Check the wiring connection of the pressure switch with the controller - Check the electrical power of the differential pressure switch
		The pressure switch is broken	Replace the pressure switch
<b>Cooling DX: Alarm</b>	This alarm occurs when the alarm signal from the external condensing unit is active	<b>Causes</b>	<b>Solutions</b>
		The alarm signal of the condensing unit is not connected to the controller	Check the wiring connection between the input "DX Coil step #1 (#2, or #3) Alarm" of the controller and alarm output of the condensing unit
		The condensing unit is in a fault state	- Refer to troubleshooting of the condensing unit - Check the electrical connection of the condensing unit
<b>Supply fan: Alarm</b>	Differential pressure switch of the supply fan active or fan overload.  This alarm occurs when the differential pressure switch of the supply fan detects a pressure difference too high before and after the supply fan or if the fan is in overload.	<b>Causes</b>	<b>Solutions</b>
		The pressure switch is not connected	Check the wiring connection of the pressure switch
		The belt is broken	Change the belt
		The pressure switch is broken	Replace the pressure switch
		The fan is broken	Replace the fan
		The fan is in overload	Refer to the troubleshooting of the fan
<b>Return fan: Alarm</b>	Differential pressure switch of the return fan active or fan overload.  This alarm occurs when the differential	<b>Causes</b>	<b>Solutions</b>
		The pressure switch is not connected	Check the wiring connection of the pressure switch
		The belt is broken	Change the belt

Alarm String	Description	Possible causes & solutions	
	pressure switch of the return fan detects a pressure difference too high before and after the supply fan or if the fan is in overload.	The pressure switch is broken	Replace the pressure switch
		The fan is broken	Replace the fan
		The fan is in overload	Refer to the troubleshooting of the fan
<b>Supply Fan Deviation Alm: Alarm</b>	Setpoint deviation alarm on the supply fan.  This alarm occurs when fan actual controlled value (Pa or m <sup>3</sup> /h) differs from the setpoint for a predefined period.	<b>Causes</b>	<b>Solutions</b>
		Supply fan is far from the set point for a predefined period	Check supply fan condition
<b>Return Fan Deviation Alm: Alarm</b>	Setpoint deviation alarm on the return fan.  This alarm occurs when fan actual controlled value (Pa or m <sup>3</sup> /h) differs from the setpoint for a predefined period.	<b>Causes</b>	<b>Solutions</b>
		Return fan is far from the set point for a predefined period	Check return fan condition
<b>Retrn Hum rel: under range</b>	Return/Room air humidity over limit or error condition on the air humidity sensor	<b>Causes</b>	<b>Solutions</b>
		The humidity sensor is not connected	Check the wiring connection of the humidity sensor
		The humidity sensor is broken	Replace the humidity sensor
<b>Air qual (CO2): Alarm</b>	Air quality alarm, percentage of CO <sub>2</sub> too high. This alarm occurs when the value of CO <sub>2</sub> is out the allowable range, or error condition in the air quality sensor	<b>Causes</b>	<b>Solutions</b>
		The percentage of CO <sub>2</sub> in the air is too high	Modify the settings of the AHU to reduce the percentage of CO <sub>2</sub> :  - Increase supply fan speed
		The air quality sensor is not connected	Check the wiring connection of the air quality sensor

Alarm String	Description	Possible causes & solutions	
		The air quality sensor is broken	Replace the air quality sensor
<b>Electrical Heating: Alarm</b>	Electrical heating device possible malfunction. This alarm occurs when the electrical heating device communicate to the controller an alarm condition through the digital input "Electric Heaters Overload"	<b>Causes</b>	<b>Solutions</b>
		The Electrical heating device is broken	Replace the Electrical heating device
		The Electrical heating device is not connected	Check the wiring connection of the Electrical heating device
<b>Supply press: under range [Professional]</b>	Problem with the supply air pressure sensor	<b>Causes</b>	<b>Solutions</b>
		Supply pressure sensor not connected	Check the wiring connection of the supply sensor. Check the electrical power of the device
<b>Return press: under range [Professional]</b>	Problem with the return air pressure sensor	Supply pressure sensor broken	Replace the sensor
		<b>Causes</b>	<b>Solutions</b>
<b>Rtrn tmp fire alarm: Alarm</b>	Return air temperature too high, possible presence of fire	Return pressure sensor not connected	Check the wiring connection of the return sensor. Check the electrical power of the device
		Return pressure sensor broken	Replace the sensor
<b>Supply tmp fire alm: Alarm</b>	Supply air temperature too high, possible presence of fire	<b>Causes</b>	<b>Solutions</b>
		Presence of fire	
<b>Supply tmp fire alm: Alarm</b>	Supply air temperature too high, possible presence of fire	Return temperature sensor broken	Verify if in the alarm list there is some alarm related to the return temperature sensor and in this case refer to it
		<b>Causes</b>	<b>Solutions</b>
<b>Supply tmp fire alm: Alarm</b>	Supply air temperature too high, possible presence of fire	Supply temperature sensor broken	Verify if in the alarm list there is some alarm related to the supply temperature sensor and in this case refer to it
		Presence of fire	

Alarm String	Description	Possible causes & solutions	
<b>Fire alarm: Alarm</b>	Fire alarm active.  This alarm occurs when the fire detector device detects the presence of fire	<b>Causes</b>	<b>Solutions</b>
		Presence of fire	
		If no fire is present, the fire alarm system could be broken	Check the Fire alarm system
<b>Heating Frost: Frost</b>	This alarm occurs when the external unit communicate to the controller (through the digital input "Frost Switch") that there could be ice on the exchanger of the external unit	<b>Causes</b>	<b>Solutions</b>
		No heating from the exchanger	Check hydraulic circuits and his temperature, 3way valve, external unit
		Outside temperature very low	The alarm will auto-reset when "Frost Switch" deactivates. If this alarm occurs several times, try to increase "Frost sp" or "Frost Off Delay" (Refer to Section 15.8)
<b>Recovery: Alarm [Modular]</b>	This alarm occurs when the Heat Wheel recovery device communicate to the controller (through the digital input "Heat Wheel Alarm") that an alarm state has been detected	<b>Causes</b>	<b>Solutions</b>
		Error on the Heat Wheel	Check the operating manual of the Heat Wheel
<b>I/O Extension module: Alarm</b>	Communication malfunction between the controller and an expansion module	<b>Causes</b>	<b>Solutions</b>
		One or more expansion modules are not connected to the controller	Check the wiring connection between the expansion modules and the controller
		One or more expansion modules are broken	Change the expansion module
<b>ERQ 1 alarm : Alarm</b>	Digital input related to the ERQ 1 is closed	<b>Causes</b>	<b>Solutions</b>
		Error on the ERQ	Check the operating manual of the ERQ
<b>ERQ 2 alarm : Alarm</b>	Digital input related to the ERQ 2 is closed	<b>Causes</b>	<b>Solutions</b>
		Error on the ERQ	Check the operating manual of the ERQ

Alarm String	Description	Possible causes & solutions	
<b>ERQ 3 alarm :</b> <b>Alarm</b>	Digital input related to the ERQ 3 is closed	<b>Causes</b>	<b>Solutions</b>
		Error on the ERQ	Check the operating manual of the ERQ
<b>ERQ 4 alarm :</b> <b>Alarm</b>	Digital input related to the ERQ 4 is closed	<b>Causes</b>	<b>Solutions</b>
		Error on the ERQ	Check the operating manual of the ERQ
<b>Emergency Stop:</b> <b>Alarm</b>	Digital input related to Emergency stop button is open	<b>Causes</b>	<b>Solutions</b>
		Emergency stop button pressed	Release the emergency stop button

## 18. About Unit

About Unit is the last item of the controller main menu and gives general information about the AHU controller.

*HMI Path: Main Menu -> About Unit*

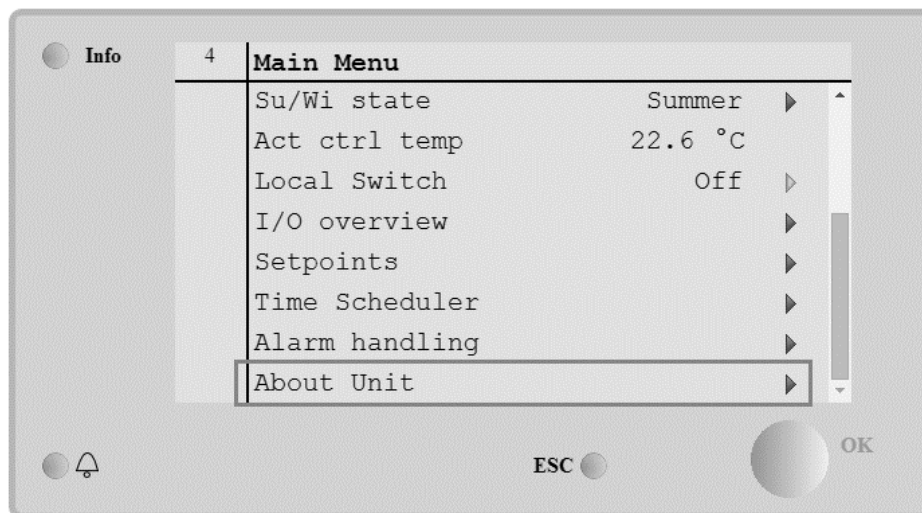

Through this section it is possible to:

- Visualize and modify date and time;

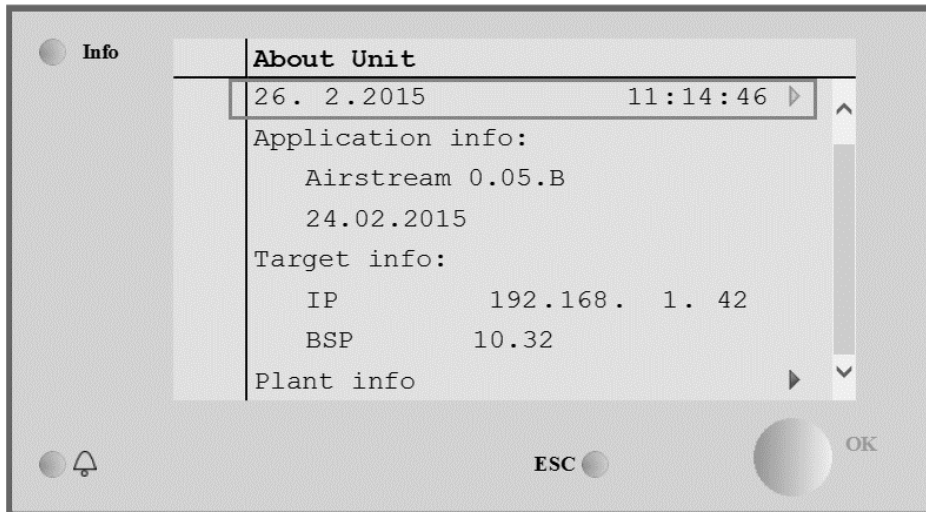

- Visualize useful information about software application installed;

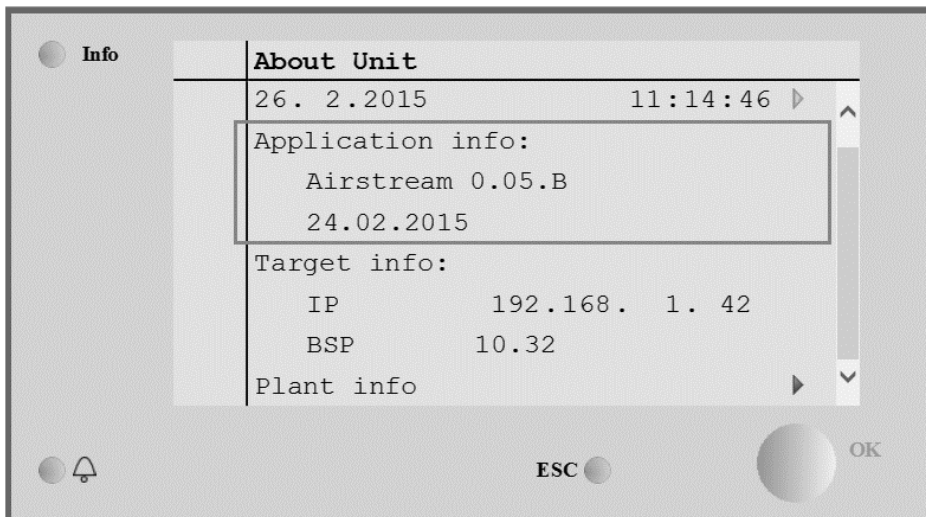

- Visualize the actual controller IP address and firmware version installed;

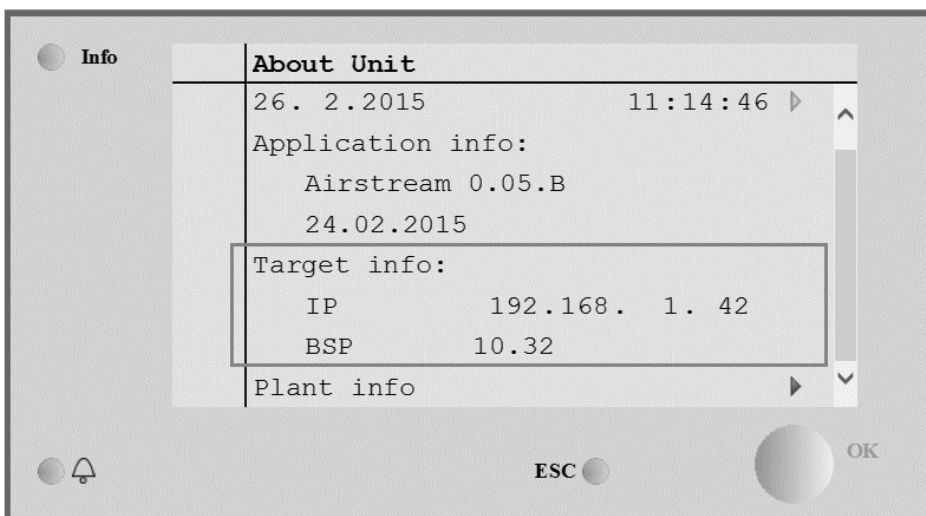

- Modify information about the plant location;



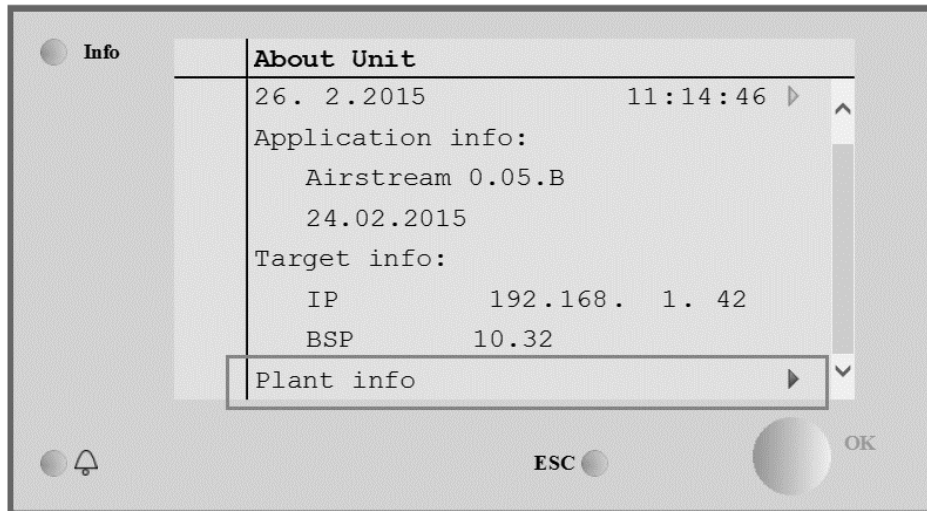

## Appendix A: Room Unit Module - POL822

This chapter explains the functionality of the Room Unit module (POL822) that is used to measure the room temperature and to manage basic control of the AHU, like:

- AHU state changeover
- Summer/Winter mode changeover
- Offset on the temperature setpoint
- Enabling and disabling of the "Occupancy" function
- Set date and time
- View actual fan speed

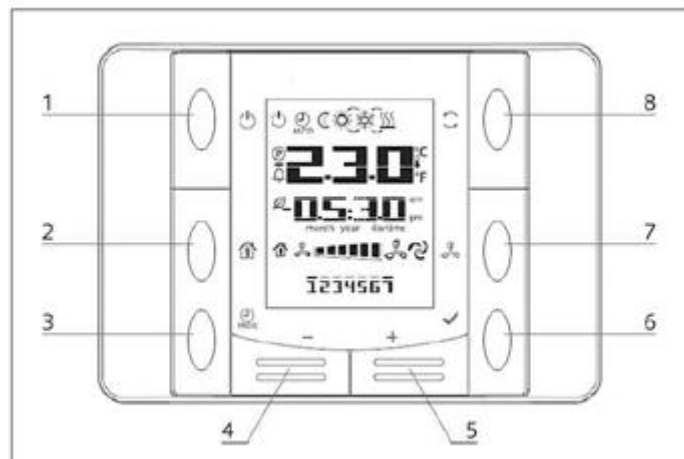

**Button Overview**

(1) On/Off 



- AHU state changeover.

(2) Home 

- Return button & Enabling/Disabling Occupancy mode.

(3) Program 

- Set date/time.

(4) Minus  and (5) Plus 

- Adjust temperature setpoint and menu navigation.

(6) OK 

- Confirm button.

(7) Fan Speed 







- Display the actual percentage speed of supply and return fans









(8) Summer/Winter Mode 

- Switch between Cooling (Summer) and Heating (Winter) mode.

### Display Overview

The table below explains all the symbols available on the display:

Display	Meaning
	Room Temperature
	Time
	Actual speed of the AHU fans
	Day of the week 1= Monday 2= Tuesday etc...
	On/Off This icon is: 1. On - when the unit is in On, Ventilation or Economy state. 2. Off - when the unit is Off. 3. Blinking - when the unit is in Test mode or in off state by Panel Switch.
	This icon is On when the AHU is in Auto mode. The actual AHU state and the relative icon (On/Off, Ventilation or Economy) are based on Time Scheduler settings.

	Heating
	Cooling
	This icon is On when the AHU is in Ventilation mode
	This icon is On when the dehumidification control is active
	Occupancy mode active
	Economy mode active
	Blinking when the AHU is in Alarm state
	This icon is On when the AHU Summer/Winter changeover is set to Auto or Pursuit mode (if available) on the main controller (POL638/687). For more details see <b>Summer/Winter state (Section 11)</b> .

Two examples of main screen display:

**Economy mode, cooling**



**Ventilation mode, heating**





### Operating instructions

#### **AHU On-Off (1)**

This button allows the user to change AHU actual operating state. The user can cycle and choose all available AHU states (Auto, On, Off, Ventilation, Economy) through this menu.

To change the AHU state follow these steps:

1. Press the On-Off button 
2. Navigate through the different available states by pressing + or - buttons
3. Confirm the change of state by pressing for at least 1 second the Confirm button 
4. To return to the main screen page without taking any action, either press the Home button  or wait for 5 seconds

### **Occupancy On-Off (2)**



The Occupancy is a function that allows to run the AHU for fixed period (defined on the main controller under "**Status/Settings -> Occupancy Tm**") when it is Off via time scheduler.

This means that the Occupancy function can only work when the AHU is controlled via time scheduler

HMI Path: Main Page → Ctrl Source = Local

HMI Path: Main Page → Local Switch = Auto

To activate/deactivate the Occupancy function follow these steps:

1. Press the Home button 
2. Navigate through the different available states by pressing + or – buttons
3. Confirm the change of state by pressing for at least 1 second the Confirm button 
4. To return to the main screen page without taking any action, either press the Home button  again or wait for 5 seconds

### **Date and time (3)**

To change the date and time displayed on the main screen follow these steps:

1. Press PROG button for less than 1 second (hours blinks), then set the hour with the + and -
2. Press OK button (the hour is saved and the minutes blink), then set minutes with + and -
3. Press OK button (minutes are saved and the entire time blinks), then set the time display format (12/24 hour) with + or -
4. Press OK (the display format is saved and the year blink), set the desired year with + and -
5. Press OK (the year is saved and the display shows the month/day, the month blinks) set the month with the + and -
6. Press OK (the month is saved and the day blinks), set the day with the + and -
7. Press OK (month and day are saved, display returns to the time)
8. Press PROG (the display returns to normal view)

The display automatically returns to normal view when the PROG button is not pressed within one minute.

### **Temperature Setpoint Offset (4 & 5)**

The buttons + or - are used to define an offset from the Heat/Cool setpoint set on the main controller.



By single pressing the + or - buttons on the main screen, the actual setpoint is being displayed. Every other press increases/decreases the temperature set point of 0.1 °C.

A long press of the + or - buttons display the actual temperature offset determined with the room unit respect the main setpoint.

### **Fan Speed Display (7)**



This button allows the user to view the actual percentage speed of Supply and Return fans.

To display the actual percentage speed of AHU fans follow these steps:

1. Press the Fan Speed button 
2. Navigate through Supply fan and Return fan (if present) visualization by pressing + or – buttons
3. To return to the main screen page either press the Home button  or wait for 5 seconds

### **Summer/Winter changeover (8)**

This button allows the user to change AHU Summer/Winter state (or Cool/Heat state). To change the Summer/Winter state follow these steps:

1. Press the Summer/Winter changeover button 
2. Navigate through the different available states by pressing + or - buttons
3. Confirm the change of state by pressing for at least 1 second the Confirm button 
4. To return to the main screen page without taking any action, either press the Home button  or wait for 5 seconds



**NOTE!** When the icon  appears on the Room Unit main screen, the Su/Wi change source on the main controller is set on Auto or Pursuit and Summer/Winter mode cannot be changed via Room Unit. For more details see Summer/Winter state section.

### **Mounting instructions**

- The room unit receives its power from the connected controller via the 2-wire interface (low voltage, SELV). The room unit must be connected to the controller with an unscreened two-core twisted pair cable.

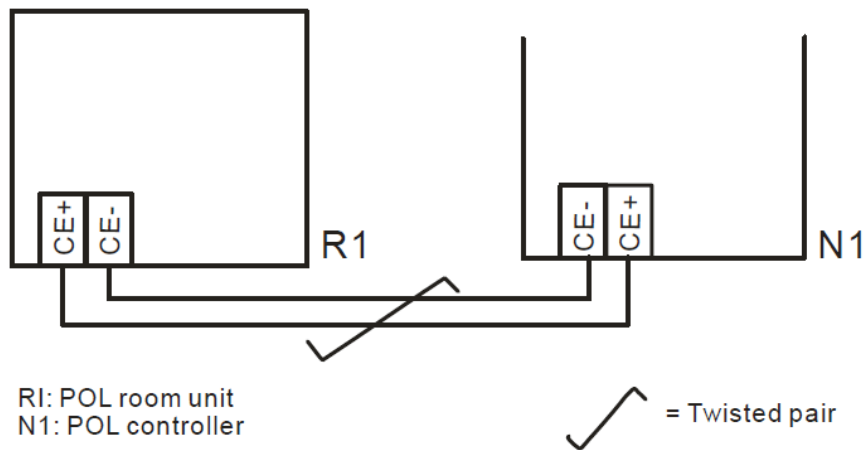
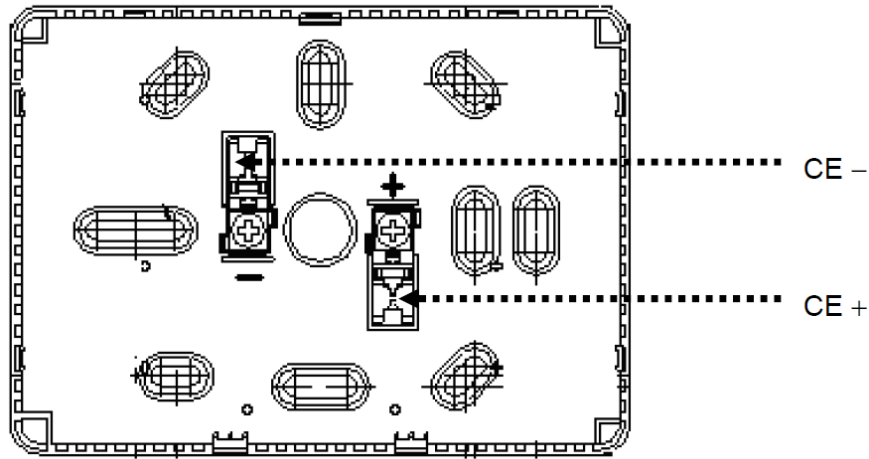

- The unit should not be mounted in recesses, shelving, behind curtains or doors or above or near direct heat sources.
- Avoid direct sun and draught.
- The conduit must be sealed on the device side, as currents of air in the conduit can affect the sensor reading.
- The admissible ambient conditions must be observed.
- Local installation regulations must be observed.
- After an interruption of the connection to the 2-wire interface, parameter initialization will restart.



***NOTE!*** The equipment is not protected against accidental connection to AC 230 V.

## Appendix B: iTM Installation & Configuration



***IMPORTANT! The following procedure is valid only for iTM software version 1.21 and later. If you have a previous version installed, please update it first by following the procedure included in iTM manual.***

The D-AHU is natively compatible with the Daikin intelligent Touch Manager (iTM), which acts as a mini building management system and enables the control of various AHU setpoints through its touchscreen interface. Refer to iTM specific operating manual for additional details on the device functionality.



If the AHU is provided with a BACnet-IP communication module (POL908), it can be connected to the iTM through an Ethernet cable and remotely controlled. The following figure shows how to connect the iTM with the BACnet-IP communication module.

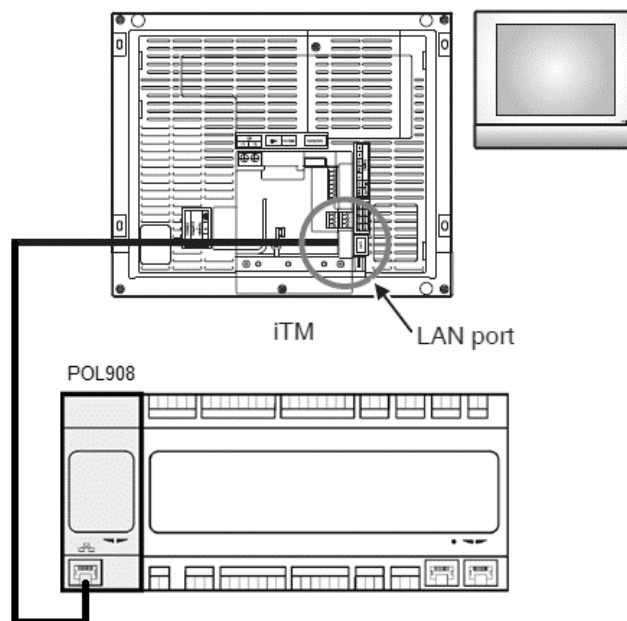

The following procedure allows the user to configure the iTM communication with the AHU controller and must be followed in order to properly set up both devices.

First configure the BACnet communication module (POL908) installed on the AHU controller. Go to the communication module configuration page located in:

**HMI Path: Main Menu -> Commissioning -> Communications -> Comm modules -> #-BACnet-IP**

Now configure the module as follow:

- **Device ID = xx** (xx must be a unique number for every AHU controller on the same network)
- **DHCP = Passive**
- **Given IP = 192.168.0.xxx** (xxx is a number between 0 & 255 and must be different from any other address in the same network)
- **Given Mask = 255.255.255.0**
- **Write setting = Active**

Restart the module using “**Restart required!**” item located at the end of the page. After the reboot, check if the configuration parameters above have been saved. See **Section 16.2.2** for additional details on POL908 configuration menu.

At this point it is necessary to configure the iTM. Check network configuration settings on the iTM by following these steps.

Touch the “**Network**” button on the “**System Settings**” tab of the “**Menu List**” screen to display the Network screen.

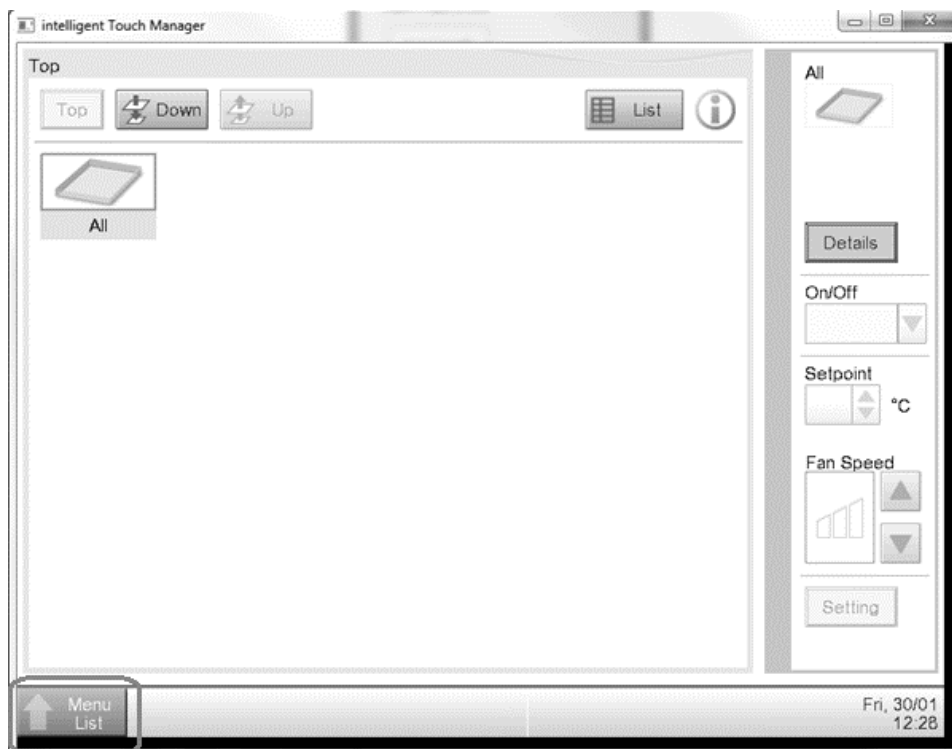





As default, the following configuration should appear:

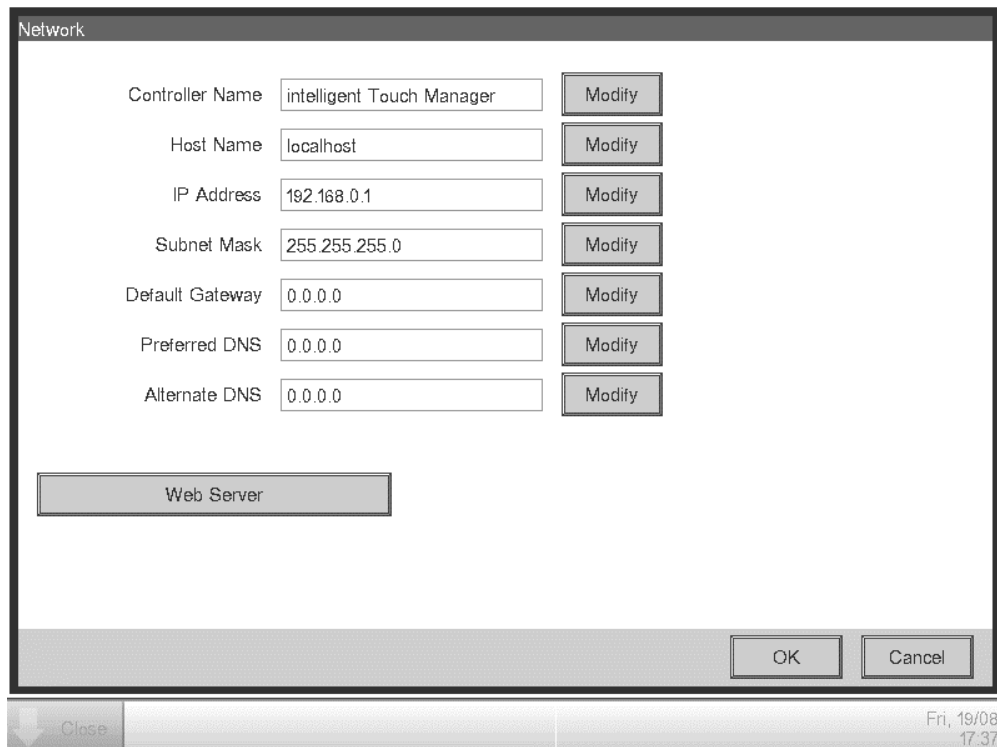

The IP address must be set to "192.168.0.yyy", where **yyy** is a number between 0 & 255 and must be different from any other address in the same network.

In order to be able to configure BACnet objects on the iTM, the user must log into the Service Mode (SE) from the “Menu List” screen (refer to *iTM commissioning manual*). Once in SE mode, go to “Mgmt. Pnt DataRegist” under “Service Settings” tab.



Add an AHU device by selecting “Add -> Others -> AHU”.

Modify the “BACnet Server Device Instance” number so that it matches the “Device ID” number configured on the BACnet communication module (POL908) of the controller.

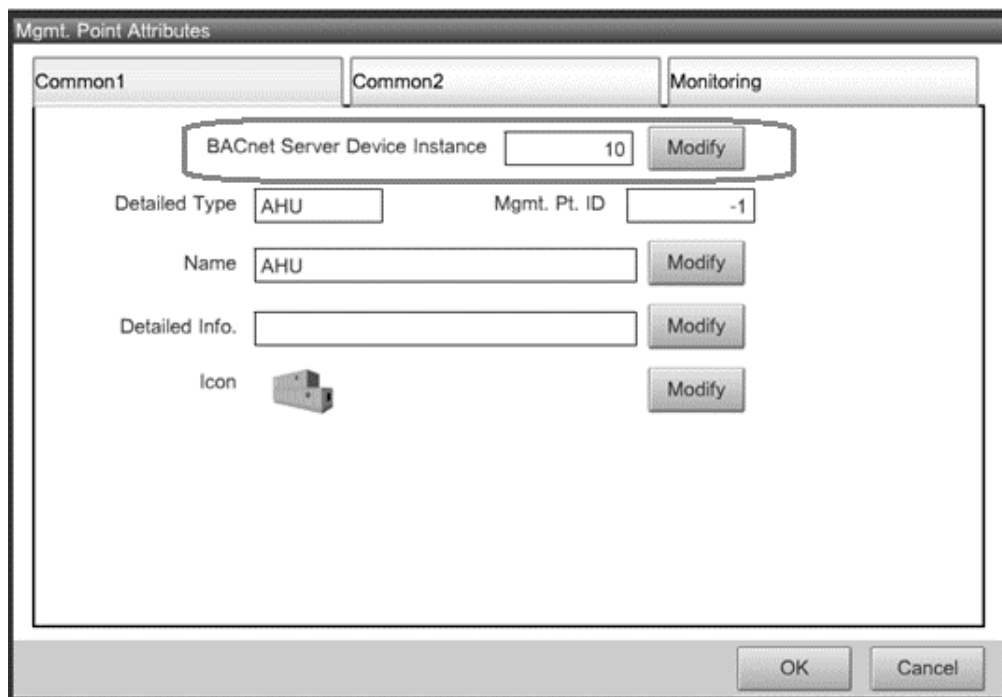

If necessary, restart the iTM. Now you can control the AHU in the iTM main screen.

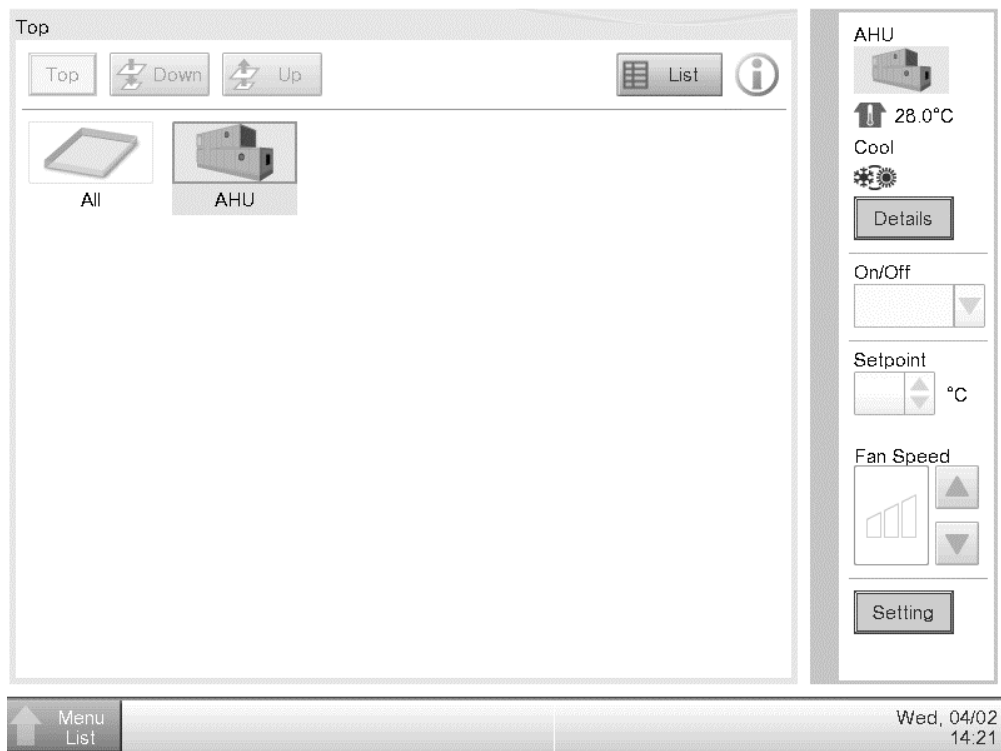

The present publication is drawn up by of information only and does not constitute an offer binding upon Daikin Applied Europe S.p.A.. Daikin Applied Europe S.p.A. has compiled the content of this publication to the best of its knowledge. No express or implied warranty is given for the completeness, accuracy, reliability or fitness for particular purpose of its content, and the products and services presented therein. Specifications are subject to change without prior notice. Refer to the data communicated at the time of the order. Daikin Applied Europe S.p.A. explicitly rejects any liability for any direct or indirect damage, in the broadest sense, arising from or related to the use and/or interpretation of this publication. All content is copyrighted by Daikin Applied Europe S.p.A..

**DAIKIN APPLIED EUROPE S.p.A.**

Via Piani di Santa Maria, 72 - 00072 Ariccia (Roma) - Italia

Tel: (+39) 06 93 73 11 - Fax: (+39) 06 93 74 014

<http://www.daikinapplied.eu>