

Light Commercial

50Hz R410A

ON/OFF SERIES

Service Manual 2017

Outdoor units:

MOBA30U-12HN1-Q
MOBA30U-18HN1-Q
MOCA30U-24HN1-Q
MOD31U-36HN1-R
MOU-48HN1-R
MOUA-60HN1-R

Indoor units:

MCA3-12HRN1-Q1
MCA3-18HRN1-Q1

MCD-18HRN1-Q1
MCD-24HRN1-Q1
MCD-36HRN1-R1
MCD-48HRN1-R
MCD-60HRN1-R

MTB-18HWN1-Q1
MTB-24HWN1-Q1
MTI-36HWN1-R1
MTB-48HWN1-R
MTB-60HWN1-R

MHG-24HWN1-Q1
MHG-36HWN1-R1
MHG-48HWN1-R
MHG-60HWN1-R

MUE-12HRN1-Q1
MUE-18HRN1-Q1
MUE-24HRN1-Q1
MUE-36HRN1-R1
MUE-48HRN1-R
MUE-60HRN1-R

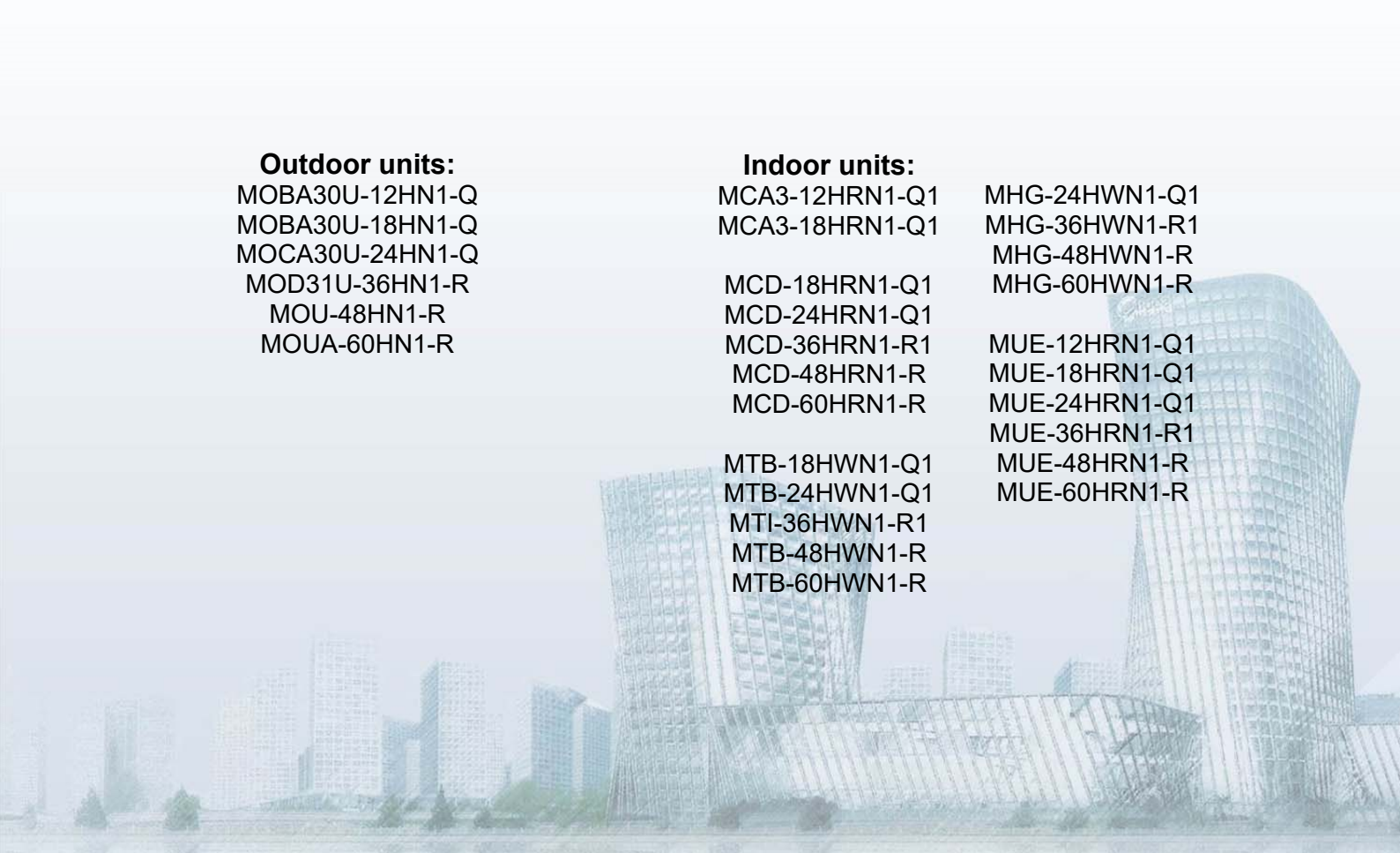

Part 1 General Information	3
Part 2 Indoor Units	9
Part 3 Outdoor Units	116
Part 4 Installation	130
Part 5 Electrical Control System	168

Part 1

General Information

1. Model Lists	4
2. External Appearance	5
3. Nomenclature	7

1. Model Lists

1.1 Indoor Units

R410A		Capacity multiplied by 1000Btu/h							
Type	Function	09	12	18	24	30	36	48	60
Four-way cassette(compact)	Cooling and heating		●	●					
Super-slim 4-way cassette	Cooling and heating			●	●		●	●	●
Middle static pressure duct	Cooling and heating			●	●		●	●	●
High static pressure duct	Cooling and heating				●		●	●	●
Ceiling & Floor	Cooling and heating		●	●	●	●	●	●	●
M Floor-standing	Cooling and heating				●			●	●

1.2 Outdoor Units

Universal Outdoor unit Model	Compressor type	Compressor Brand	Matched indoor units
Heat Pump			
MOBA30U-12HN1-Q	ROTARY	GMCC	MCA3-12HRN1-Q1 MUE-12HRN1-Q1
MOBA30U-18HN1-Q	ROTARY	GMCC	MCA3-18HRN1-Q1 MUE-18HRN1-Q1 MTB-18HWN1-Q1 MCD-18HRN1-Q1
MOCA30U-24HN1-Q	ROTARY	GMCC	MFM-24ARN1-Q MUE-24HRN1-Q1 MHG-24HWN1-Q1 MCD-24HRN1-Q1 MTB-24HWN1-Q1
MOD31U-36HN1-R	SCROLL	EMERSON	MCD-36HRN1-R1 MUE-36HRN1-R1 MHG-36HWN1-R1 MTI-36HWN1-R1
MOU-48HN1-R	SCROLL	Panasonic	MUE-48HRN1-R MHG-48HWN1-R MTB-48HWN1-R MCD-48HRN1-R
MOUA-60HN1-R	SCROLL	Panasonic	MUE-60HRN1-R MTB-60HWN1-R MCD-60HRN1-R MHG-60HWN1-R

2. External Appearance

2.1 Indoor Units

Compact Four-way cassette



Super-slim 4-way Cassette



Middle static pressure duct



Middle static pressure duct



High static pressure duct



Ceiling & floor type



M Floor-standing



2.2 Outdoor Units



Single fan outdoor unit



Double fan outdoor unit

3. Nomenclature

3.1 Indoor Unit

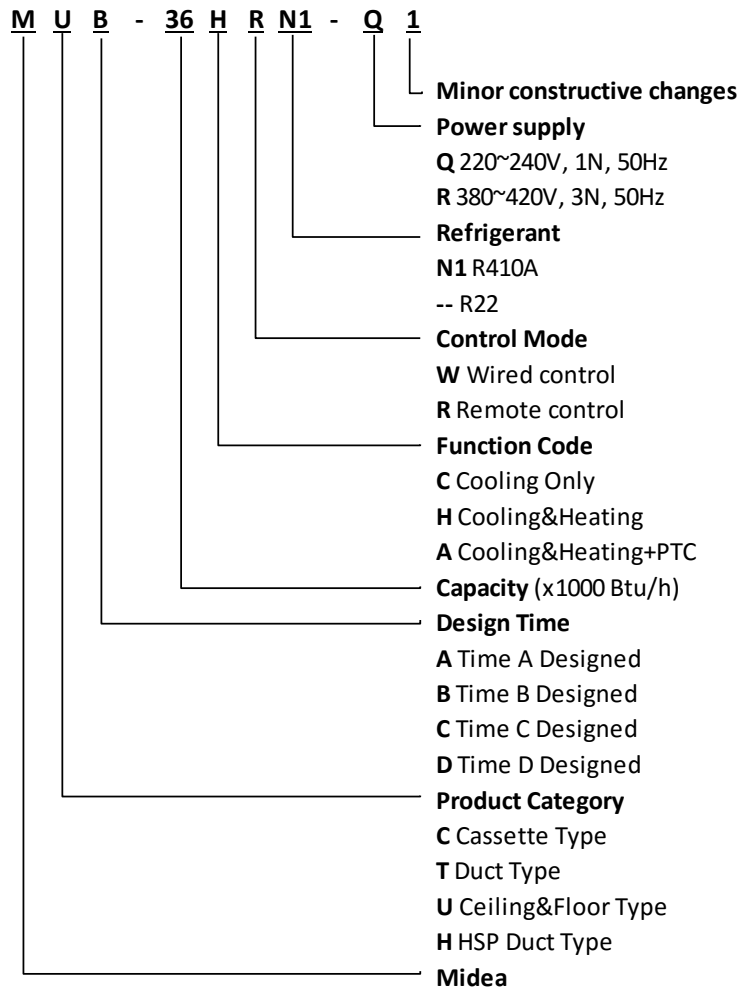

3.2 Outdoor Unit

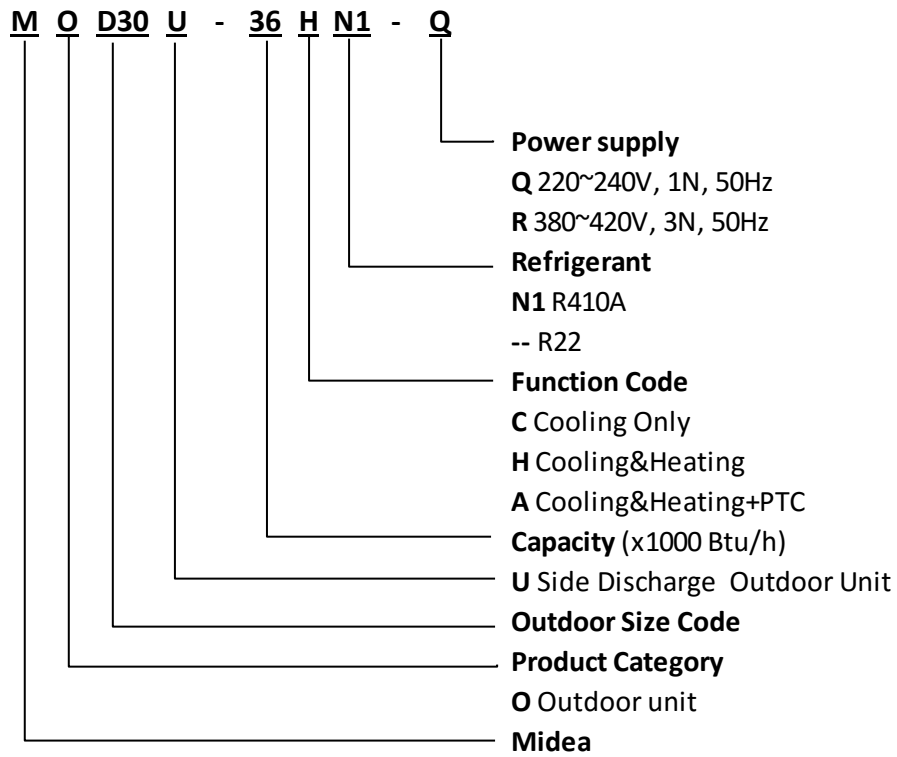

Part 2

Indoor Units

Four-way Cassette Type (Compact)	10
Four-way Cassette Type.....	23
MSP Duct Type	43
HSP Duct Type.....	65
Ceiling & Floor Type	86
Floor-standing Type.....	105

Four-way Cassette Type (Compact)

1. Features	11
2. Specification	12
3. Dimensions	12
4. Service Space	14
5. Capacity tables	14
6. Air Velocity and Temperature Distributions	15
7. Wiring Diagrams	18
9. Electric Characteristics.....	19
10. Sound Levels	20
11. The Specification of Power.....	21
12. Field Wiring	22

1. Features

1.1 Compact design

- The body size is 570×260×570mm, it's just smaller than the ceiling board, so it's very easy for installation and will not damage the decoration. The panel size is 647×50×647mm.
- The hooks are designed in the four corners of the body, which can save installation space.



1.2 Electric control box built-in design

- The E-box is simply and safely built inside the indoor unit. It's convenient for installation and maintenance. Can check the control part easily, you only need to open the air return grille.



1.3 Air passage function

- Reserves the space for air outlet from the side of indoor unit; It's availed to connect air duct from the two sides to the nearby small rooms.



2. Specification

Indoor model			MCA3-12HRN1-Q1	MCA3-18HRN1-Q1	
Outdoor model			MOBA30U-12HN1-Q	MOBA30U-18HN1-Q	
Power supply		V-ph-Hz	220~240-1-50	220~240-1-50	
Cooling	Capacity	Btu/h	12500	18300	
		kW	3,66	5,36	
	Input	W	1350	1980	
	Current	A	6	8,78	
EER		W/W	2,71	2,71	
Heating	Capacity	Btu/h	13000	19000	
		kW	3,81	5,57	
	Input	W	1320	1720	
	Current	A	5,9	7,63	
COP		W/W	2,89	3,24	
Indoor motor	fan	Model	YKT-17-6-6	YKT-27-4-6	
		Qty	1	1	
		Input	W	40.5/35.3/31.4	78/71/51/39
		Capacitor	uF	1.5UF/450V	2UF/450V
		Speed(Hi/Med/Lo)	r/min	640/540/440	890/850/685/583
Indoor coil	Number of rows		1	2	
	Tube pitch(a)x row pitch(b)		mm	21x13.37	
	Fin spacing		mm	1,3	
	Fin type			Hydrophilic aluminium	
	Tube outside dia.and type		mm	Φ7,innergroove tube	
	Coil length x height x width		mm	1380x210x13.37	
Number of circuits			3	4	
Indoor air flow (Hi/Mid/Lo)		m ³ /h	650/550/430	810/650/530	
Indoor noise level (sound pressure) (Hi/Mid/Lo)		dB(A)	42/38/36	48/41/36	
Throttle type			/	/	
Indoor unit	Dimension (WxDxH)(body)		mm	570x570x260	
	Packing (WxDxH)(body)		mm	655x655x290	
	Dimension (WxDxH)(panel)		mm	647x647x50	
	Packing (WxDxH)(panel)		mm	715x715x123	
	Net/Gross weight(body)		kg	16.3/19.1	
Net/Gross weight(panel)		kg	2.5/4.5		
Design pressure		MPa	4.2/1.5	4.2/1.5	
Drainage water pipe diameter		mm	ODΦ25	ODΦ25	
Refrigerant piping	Liquid side/Gas side	mm	Φ6.35/Φ12.7(1/4"/1/2")	Φ6.35/Φ12.7(1/4"/1/2")	
Controller			RG36C/BG(C)E	RG36C/BG(C)E	
Operation temperature		°C	17~30	17~30	
Room temperature	Cooling	°C	17~32	17~32	
	Heating	°C	0~30	0~30	

Remarks:

1.The above design and specifications are subject to change without prior notice for product improvement.

3. Dimensions

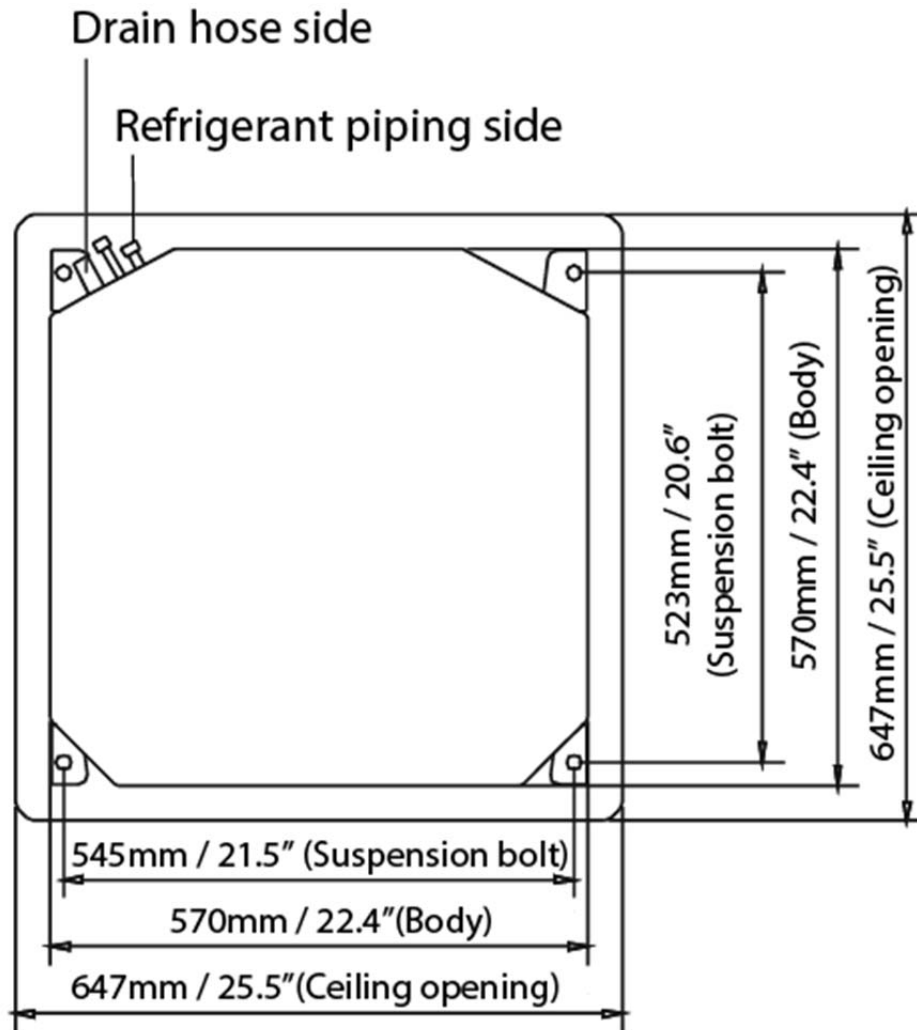

4. Service Space

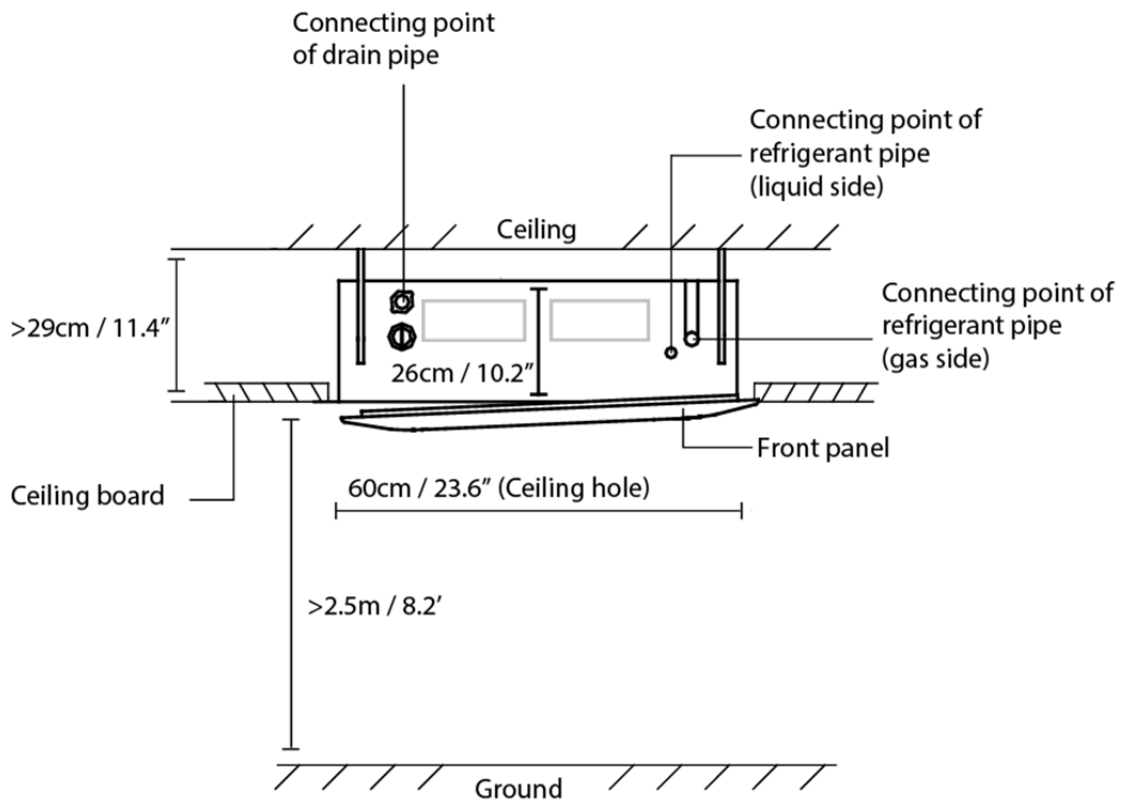
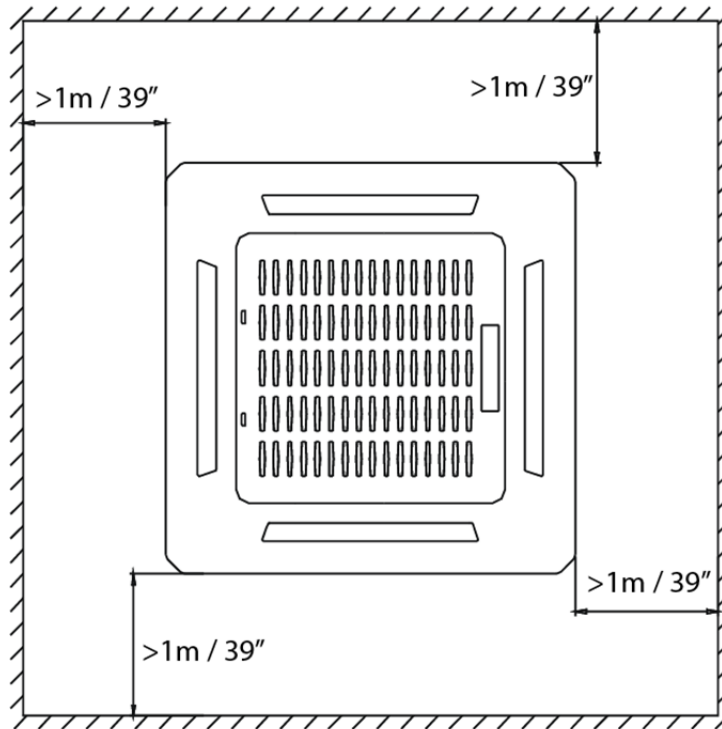

5. Capacity tables

5.1 MCA3-12HRN1-Q1 / MOBA30U-12HN1-Q

COOLING		OUTDOOR TEMPERATURE DRY					
Indoor Conditions		21°C	25°C	30°C	35°C	40°C	45°C
21°C D 15°C W	Total capacity kW	3,39	3,36	3,32	3,26	2,61	2,44
	Sensitive capacity kW	2,71	2,68	2,66	2,61	2,08	1,95
	Input kW.	3,66	3,63	3,60	3,53	3,64	3,78
24°C D 17°C W	Total capacity kW	3,46	3,43	3,40	3,33	2,66	2,50
	Sensitive capacity kW	2,77	2,74	2,72	2,66	2,13	2,00
	Input kW.	1,36	1,35	1,34	1,32	1,36	1,41
27°C D 19°C W	Total capacity kW	3,81	3,77	3,73	3,66	2,93	2,75
	Sensitive capacity kW	3,05	3,02	2,99	2,93	2,34	2,20
	Input kW.	1,40	1,39	1,38	1,35	1,39	1,44
32°C D 23°C W	Total capacity kW	4,26	4,22	4,18	4,10	3,28	3,07
	Sensitive capacity kW	3,41	3,38	3,34	3,28	2,62	2,46
	Input kW.	1,56	1,55	1,54	1,51	1,56	1,62

HEATING		OUTDOOR CONDITIONS						
Indoor Conditions		24°C D 18°C W	12°C D 11°C W	7°C D 6°C W	4°C D 3°C W	0°C D -1°C W	-5°C D -6°C W	-7°C D -8°C W
15°C	Capacity kW	4,88	4,83	4,23	3,47	2,96	2,33	2,16
	Input kW.	1,69	1,67	1,46	1,35	1,32	1,16	1,13
18°C	Capacity kW	4,66	4,61	4,04	3,31	2,83	2,22	2,06
	Input kW.	1,61	1,59	1,40	1,29	1,26	1,11	1,08
20°C	Capacity kW	4,40	4,35	3,81	3,12	2,67	2,10	1,94
	Input kW.	1,52	1,51	1,32	1,22	1,19	1,05	1,02
22°C	Capacity kW	3,74	3,70	3,24	2,66	2,27	1,78	1,65
	Input kW.	1,41	1,39	1,22	1,13	1,10	0,97	0,94
27°C	Capacity kW	3,74	3,70	3,24	2,66	2,27	1,78	1,65
	Input kW.	1,42	1,40	1,23	1,14	1,11	0,98	0,95

5.2. MCA3-18HRN1-Q1 / MOBA30U-18HN1-Q

COOLING		OUTDOOR TEMPERATURE DRY					
Indoor Conditions		21°C	25°C	30°C	35°C	40°C	45°C
21°C D 15°C W	Total capacity kW	4,96	4,91	4,87	4,77	3,82	3,58
	Sensitive capacity kW	3,97	3,93	3,89	3,82	3,05	2,86
	Input kW.	5,35	5,32	5,28	5,17	5,33	5,53
24°C D 17°C W	Total capacity kW	5,07	5,02	4,98	4,88	3,90	3,66
	Sensitive capacity kW	4,06	4,02	3,98	3,90	3,12	2,93
	Input kW.	2,00	1,99	1,97	1,93	1,99	2,07
27°C D 19°C W	Total capacity kW	5,57	5,52	5,47	5,36	4,29	4,02
	Sensitive capacity kW	4,46	4,42	4,37	4,29	3,43	3,22
	Input kW.	2,05	2,04	2,02	1,98	2,04	2,12
32°C D 23°C W	Total capacity kW	6,24	6,18	6,12	6,00	4,80	4,50
	Sensitive capacity kW	4,99	4,95	4,90	4,80	3,84	3,60
	Input kW.	2,30	2,28	2,26	2,22	2,28	2,37

HEATING		OUTDOOR CONDITIONS						
Indoor Conditions		24°C D 18°C W	12°C D 11°C W	7°C D 6°C W	4°C D 3°C W	0°C D -1°C W	-5°C D -6°C W	-7°C D -8°C W
15°C	Capacity kW	7,14	7,06	6,18	5,07	4,33	3,40	3,15
	Input kW.	2,20	2,18	1,91	1,76	1,72	1,52	1,48
18°C	Capacity kW	6,82	6,74	5,90	4,84	4,13	3,25	3,01
	Input kW.	2,10	2,08	1,82	1,69	1,64	1,45	1,41
20°C	Capacity kW	6,43	6,36	5,57	4,57	3,90	3,06	2,84
	Input kW.	1,99	1,96	1,72	1,59	1,55	1,37	1,33
22°C	Capacity kW	5,47	5,41	4,73	3,88	3,31	2,60	2,41
	Input kW.	1,83	1,81	1,59	1,47	1,43	1,26	1,23
27°C	Capacity kW	5,47	5,41	4,73	3,88	3,31	2,60	2,41
	Input kW.	1,85	1,83	1,60	1,48	1,45	1,27	1,24

6. Air Velocity and Temperature Distributions(Reference Data)

Airflow velocity

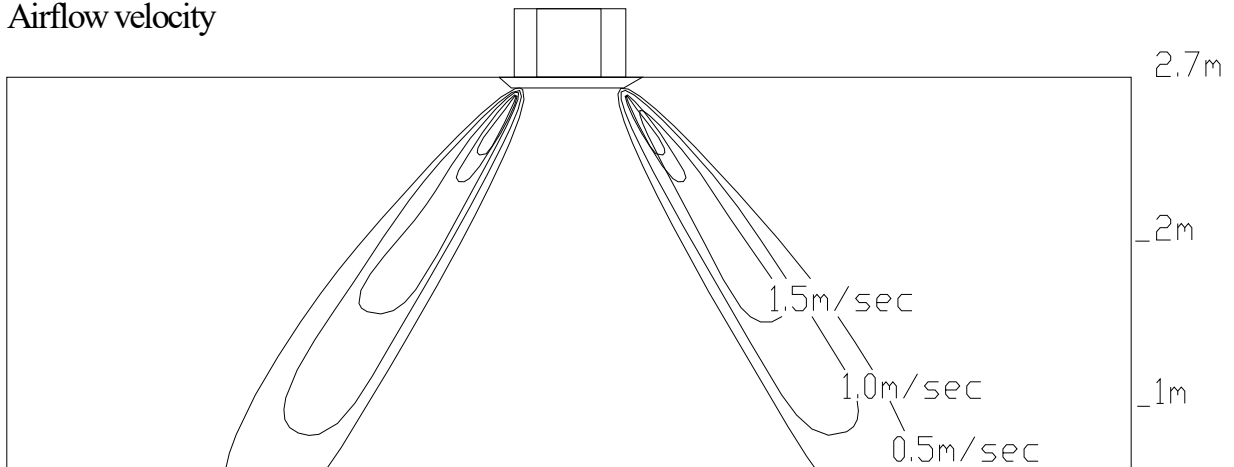

Temperature

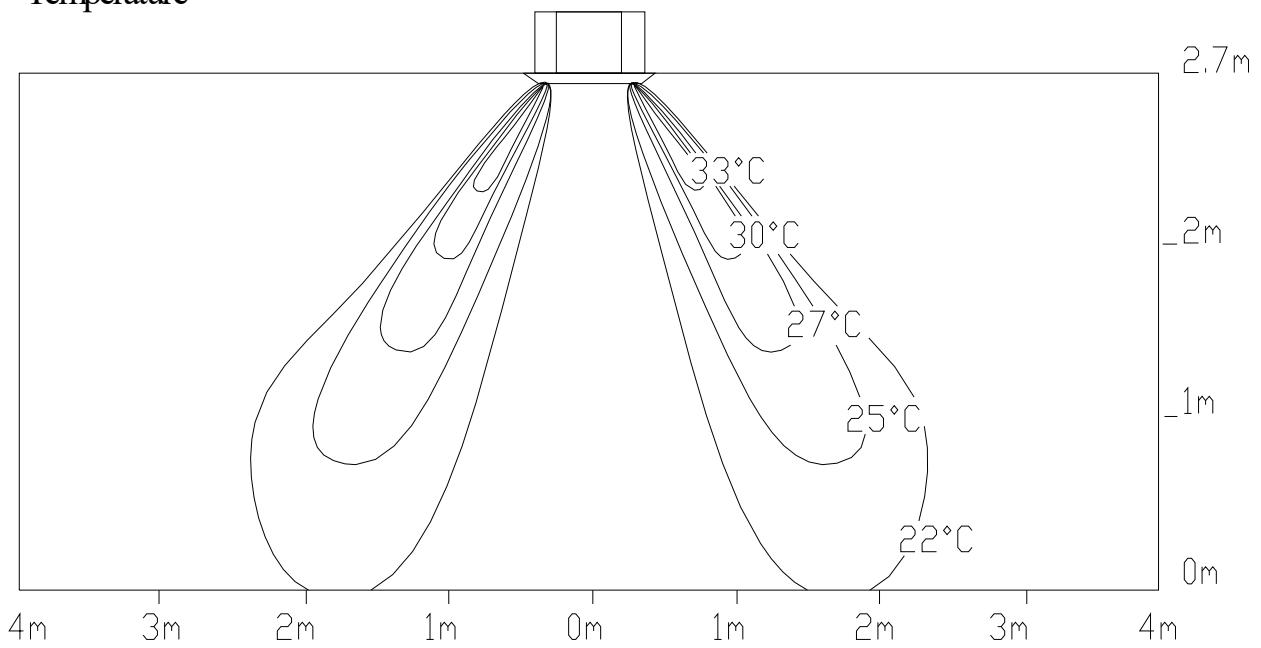

7. Wiring Diagrams

MCA3-12HRN1-Q1, MCA3-18HRN1-Q1

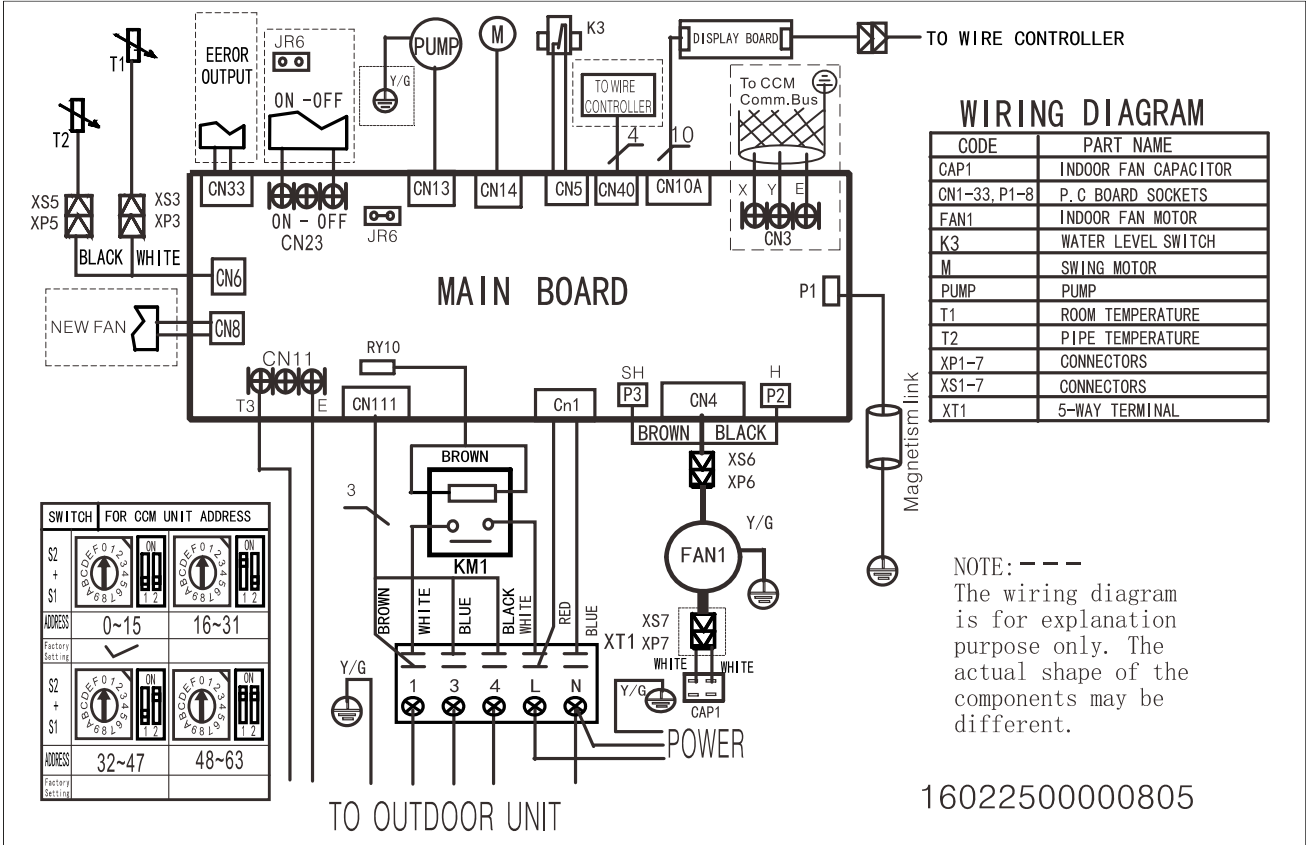

8. Electric Characteristics

Model	Indoor Units				Power Supply
	Hz	Voltage	Min.	Max.	MFA
MCA3-12HRN1-Q1	50	220-240V	198V	254V	16
MCA3-18HRN1-Q1	50	220-240V	198V	254V	16

Note:

MFA: Max. Fuse Amps. (A)

9. Sound Levels

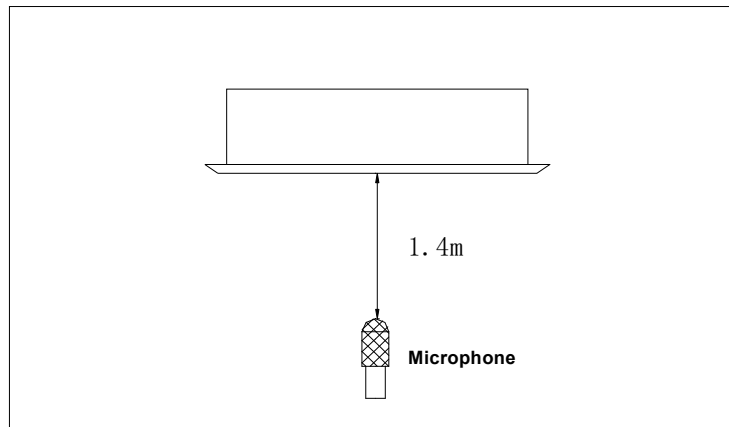

Model	Noise level dB(A)		
	H	M	L
MCA3-12HRN1-Q1	42	38	36
MCA3-18HRN1-Q1	48	41	36

10. The Specification of Power

		Type	MCA3-12HRN1-Q1 MCA3-18HRN1-Q1
Power	Phase		1-phase
	Frequency and Voltage		220-240V, 50Hz
Circuit Breaker/ Fuse (A)			20/16
Indoor Unit Power Wiring (mm ²)			3×2.5
Indoor/Outdoor Wiring	Connecting	Ground Wiring	2.5
		Outdoor Unit Power Wiring	3×2.5
		Strong Electric Signal	2×1.0
		Weak Electric Signal	(2×0.75/2×0.5)

11. Field Wiring

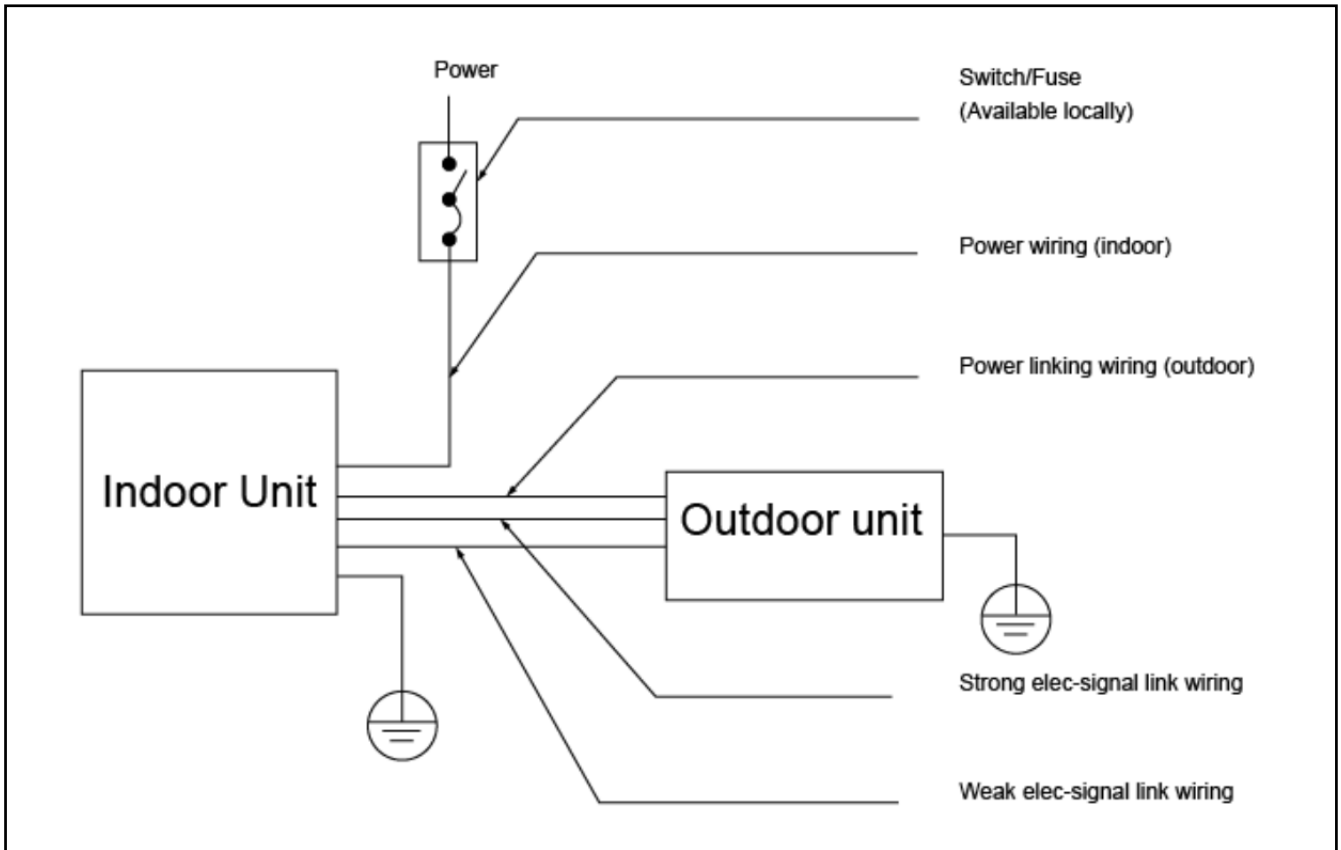

Air Condition Link-Circuit

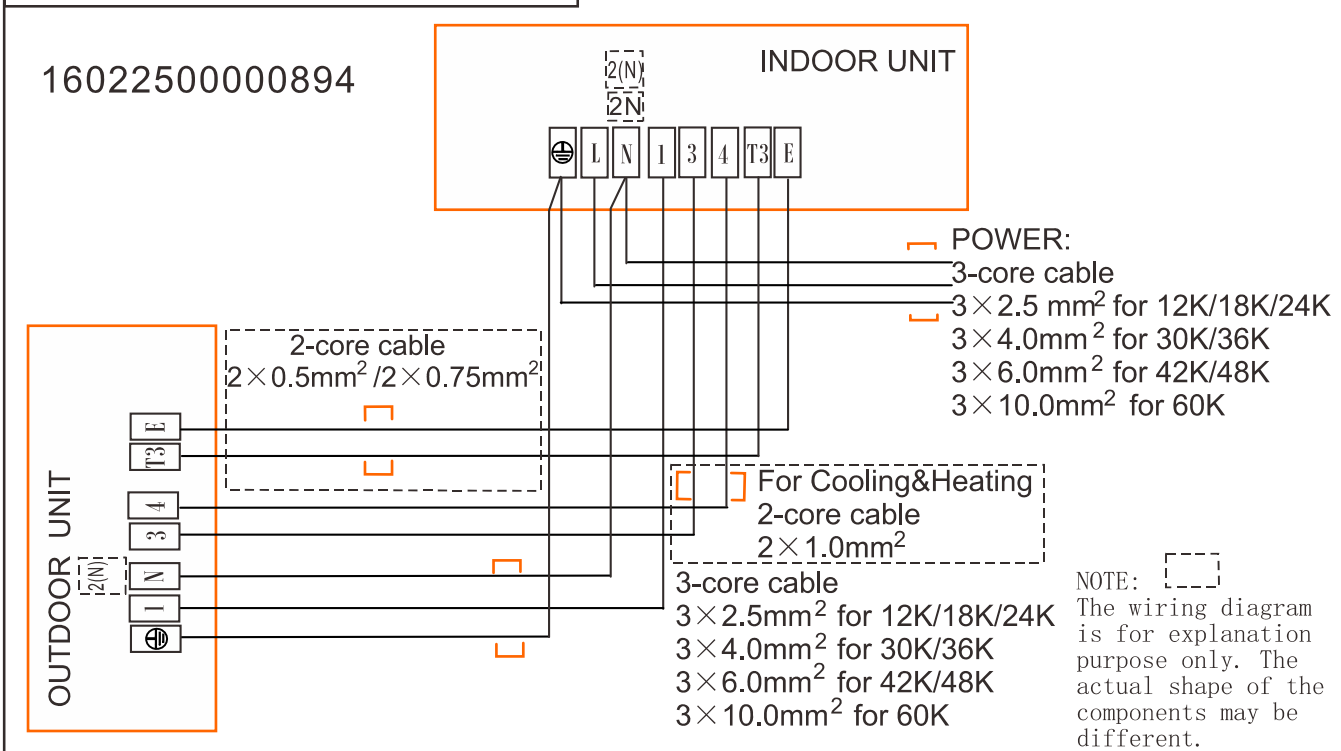

Four-way Cassette Type

1. Features	24
2. Specification.....	26
3. Dimensions.....	26
4. Service Space.....	29
5. Capacity tables.....	30
6. Wiring Diagrams	35
7. Electric Characteristics	38
8. Sound Levels.....	39
9. The Specification of Power	40
10. Field Wiring	41

1. Features

1.1 Overview

- Compact design, super slim body size, less space requiring in installation
- Each louver can be separately controlled, more comfort air blowing is possible.

1.2 Fresh air intake function

- Fresh air fulfills air quality more healthy and comfortable.
- Ventilation motor is optional to increase the effect of fresh air.

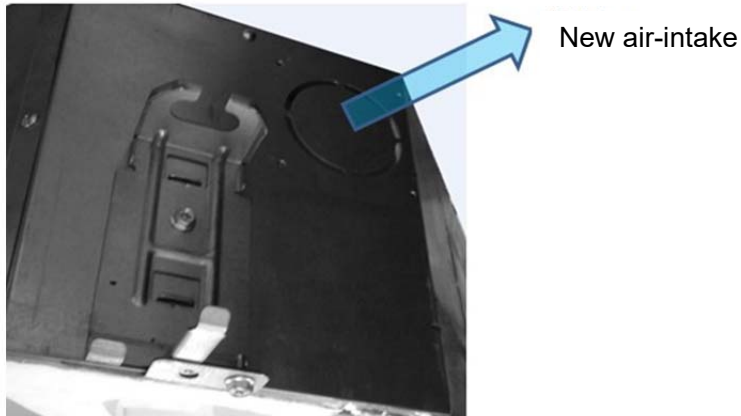

1.3 External air duct design

- Reserve external air duct, more flexible for the air supply.

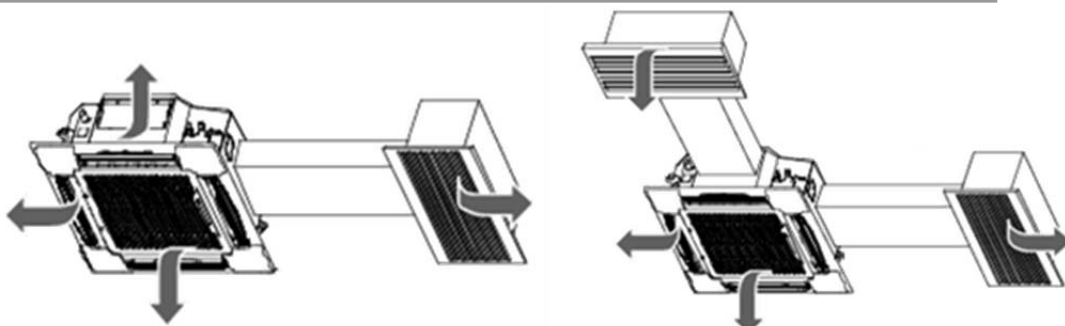

1.4 Built-in draining pump

- Due to the improvement of structure, more convenient to repair or replace the draining pump.

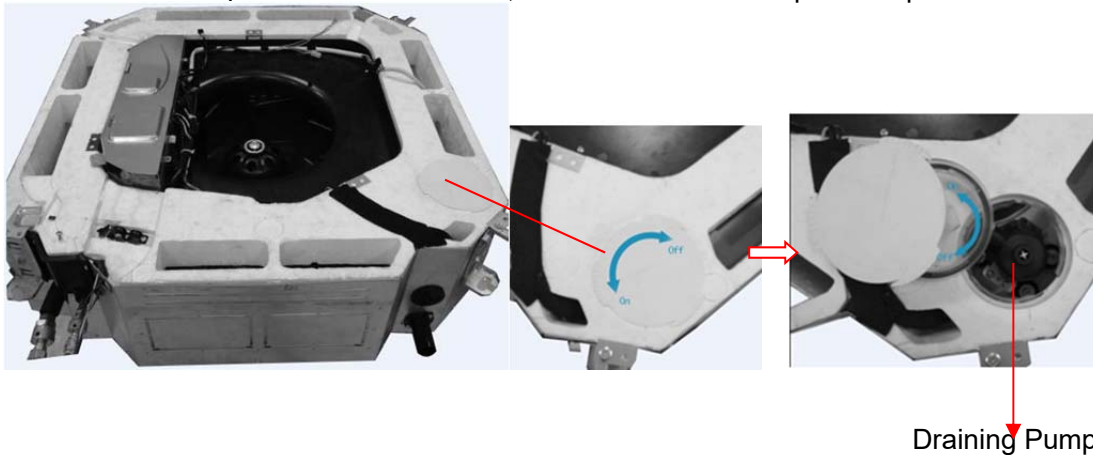

- Built-in draining pump to make sure condensed water drain out reliably.

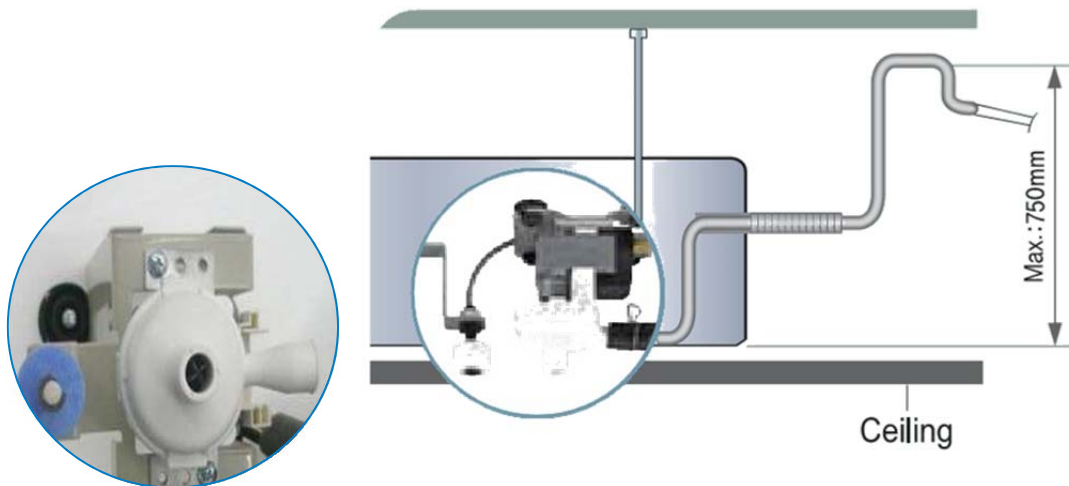

1.5 Terminals for alarm lamp and long-distance on-off controller connection are standard

- Reserve terminals for the connection of alarm lamp and long-distance on-off controller, more human control.

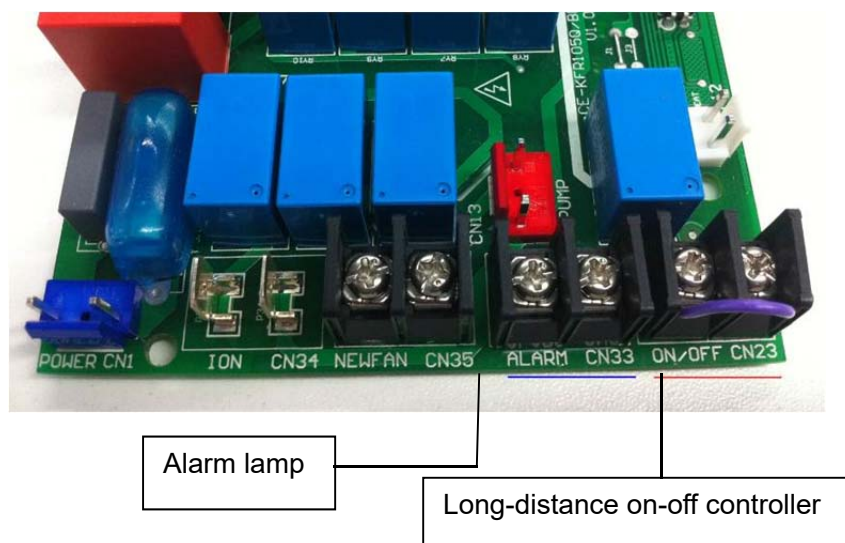

2. Specification

Indoor model			MCD-18HRN1-Q1	MCD-24HRN1-Q1	
Outdoor model			MOBA30U-18HN1-Q	MOCA30U-24HN1-Q	
Power supply		V-ph-Hz	220-240-1-50	220-240-1-50	
Cooling	Capacity	Btu/h	18000	24000	
		kW	5,28	7,03	
	Input	W	1990	2600	
	Current	A	8.82	12.48	
EER		W/W	2,65	2,71	
Heating	Capacity	Btu/h	19000	26000	
		kW	5,57	7,62	
	Input	W	1740	2400	
	Current	A	7,72	11,52	
COP		W/W	3,20	3,18	
Indoor fan motor	Model		YKT-42-6-6	YKT-42-6-6	
	Qty		1	1	
	Input	W	81/69/63	81/69/63	
	Capacitor	uF	2UF/450V	3.5UF/450V	
	Speed(Hi/Med/Lo)		r/min	520/390/340	520/390/340
Indoor coil	Number of rows		2	2	
	Tube pitch(a)x row pitch(b)		mm	21x13.37	21x13.37
	Fin spacing		mm	1,4	1,4
	Fin type			Hydrophilic aluminium	Hydrophilic aluminium
	Tube outside dia.and type		mm	Φ7,innergroove tube	Φ7,innergroove tube
	Coil length x height x width		mm	2010x168x26.74	2010x168x26.74
	Number of circuits			8	8
Indoor air flow (Hi/Mid/Lo)		m ³ /h	900/750/600	1200/1050/900	
Indoor noise level (sound pressure) (Hi/Mid/Lo)		dB(A)	43/40/35	50/45/41	
Throttle type			/	/	
Indoor unit	Dimension (WxDxH)(body)		mm	840x840x205	840x840x205
	Packing (WxDxH)(body)		mm	900x900x217	900x900x217
	Dimension (WxDxH)(panel)		mm	950x950x55	950x950x55
	Packing (WxDxH)(panel)		mm	1035x1035x90	1035x1035x90
	Net/Gross weight(body)		kg	22/25.5	22.1/25.5
Net/Gross weight(panel)		kg	5/8	5/8	
Design pressure		MPa	4.2/1.5	4.2/1.5	
Drainage water pipe diameter		mm	ODΦ32	ODΦ32	
Refrigerant piping	Liquid side/Gas side	mm	Φ6.35/Φ12.7(1/4"/1/2")	Φ9.52Φ15.9(3/8"/5/8")	
Controller			RG36C/BG(C)E	RG36C/BG(C)E	
Operation temperature		°C	17~30	17~30	
Room temperature	Cooling	°C	17~32	17~32	
	Heating	°C	0~30	0~30	

Indoor model			MCD-36HRN1-R1	MCD-48HRN1-R	MCD-60HRN1-R
Outdoor model			MOD31U-36HN1-R	MOU-48HN1-R	MOUA-60HN1-R
Power supply		V,Hz,Ph	380~415,50,3	380~415,50,3	380~415,50,3
Cooling	Capacity	Btu/h	36000	48000	55000
	Input	W	3600	5191	6272
	Current	A	6	9.2	11
	EER	W/W	2,93	2.71	2.57
Heating	Capacity	Btu/h	36000	52000	61000
	Input	W	3650	4763	5843
	Current	A	6.1	8.5	10.3
	COP	W/W	2,89	3.2	3.06
Indoor fan motor	Model		YKS-125-6-3	YDK125-6E	YDK125-6E
	Qty		1	1	1
	Input	w	174/145/121	209/145/121	209/145/121
	Capacitor	uF	5UF/450V	5UF/450V	5UF/450V
	Speed(hi/mi/lo)	r/min	690/610/540	775/610/540	775/610/540
Indoor coil	a.Number of rows		2.0	3	3
	b.Tube pitch(a)x row pitch(b)	mm	21x13.37	21x13.37	21x13.37
	c.Fin spacing	mm	1.4	1,4	1,4
	d.Fin type (code)		Hydrophilic aluminium	Hydrophilic aluminium	Hydrophilic aluminium
	e.Tube outside dia.and type	mm	Φ7,innergroove tube	Φ7,innergroove tube	Φ7,innergroove tube
	f.Coil length x height x width	mm	2010x210x26.74	2080x210x40.11	2080x252x40.11
	g.Number of circuits		10	10	12
Indoor air flow (Hi/Med/Lo)	m ³ /h	1731/1494/1297	1900/1600/1400	2000/1700/1500	
Sound level (sound pressure)	dB(A)	51.7/48.0/45.2	53/48/44	53/48/44	
Throttle type		/	/	/	
Indoor unit	Dimension (W x Dx H) (body)	mm	840x840x245	840x840x245	840x840x287
	Packing (W x Dx H)(body)	mm	900x900x257	900x900x265	900x900x292
	Dimension (W x Dx H)(panel)	mm	950x950x55	950x950x55	950x950x55
	Packing (W x Dx H)(panel)	mm	1035x1035x90	1035x1035x90	1035x1035x90
	Net/Gross weight(body)	kg	24.9/28.8	27/32	29/34
	Net/Gross weight(panel)	kg	5/8	5/8	5/8
Design pressure	MPa	4.2/1.5	4.2/1.5	4.2/1.5	
Drainage water pipe dia.	mm	ODΦ32	ODΦ32	ODΦ32	
Refrigerant piping	Liquid side/ Gas side	mm	Φ9.52/Φ19(3/8"/3/4")	Φ12.7/Φ19	Φ12.7/Φ19
Controller			RG36C/BG(C)E	RG36C/BG(C)E	RG36C/BG(C)E
Operation temperature	°C		17~30	17~30	17~30
Room temperature	Cooling	°C	17~32	17~32	17~32
	Heating	°C	0~30	0~30	0~30

Remarks:

1.The above design and specifications are subject to change without prior notice for product improvement.

3. Dimensions

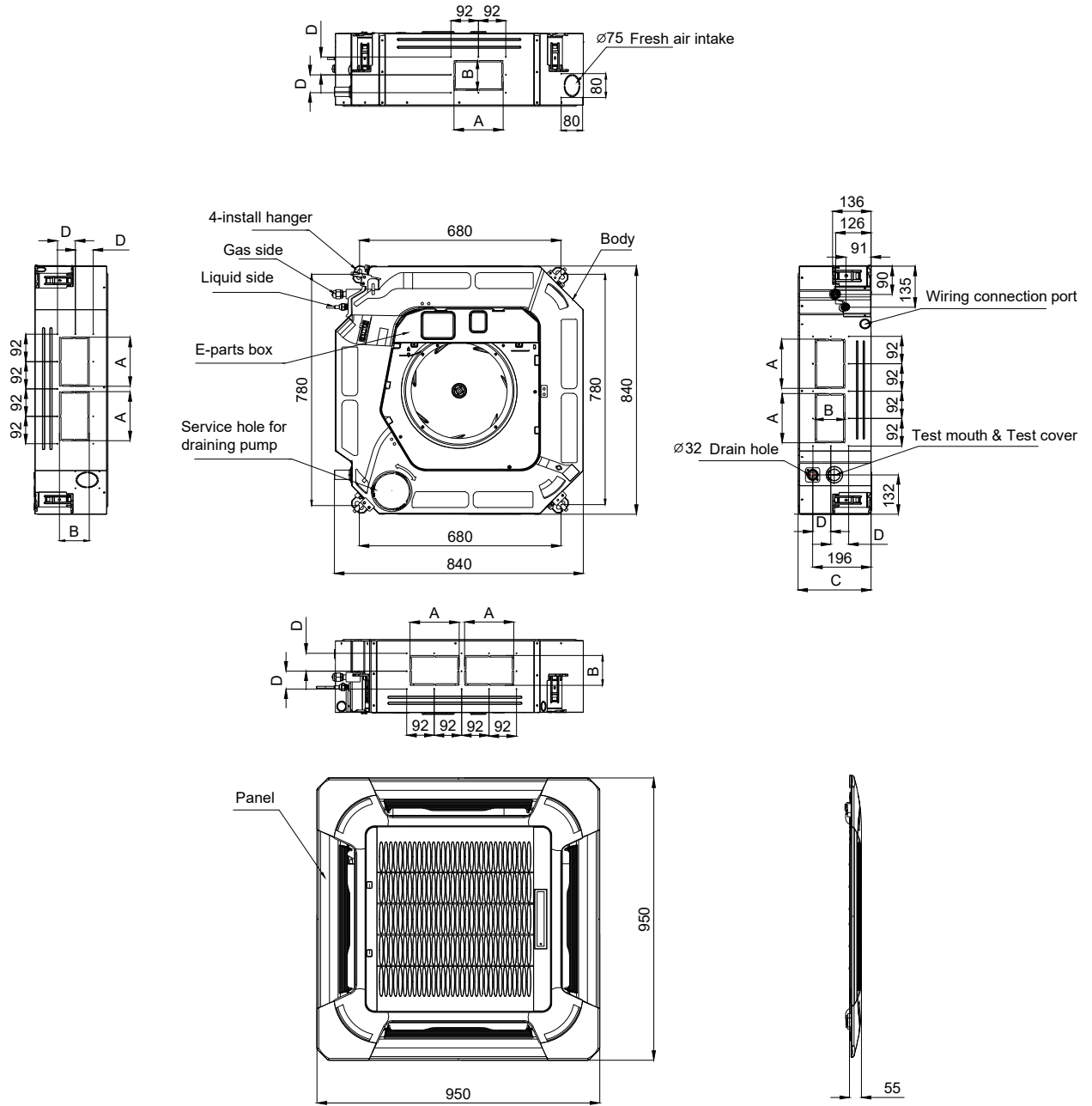

Unit: mm

Model	A	B	C	D
18/24	160	75	205	50
36/48	160	95	245	60
60	160	95	287	60

4. Service Space

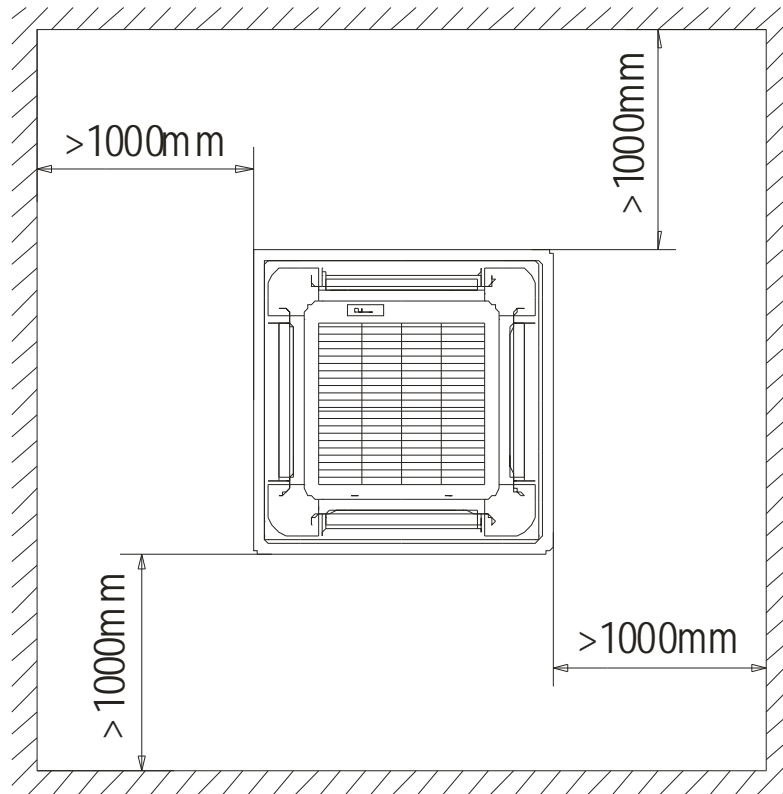

5. Capacity tables

5.1. MCD-18HRN1-Q1 / MOBA30U-18HN1-Q

COOLING		OUTDOOR TEMPERATURE DRY					
Indoor Conditions		21°C	25°C	30°C	35°C	40°C	45°C
21°C D 15°C W	Total capacity kW	6,51	6,44	6,38	6,26	5,01	4,69
	Sensitive capacity kW	5,21	5,16	5,11	5,01	4,00	3,75
	Input kW.	7,02	6,97	6,92	6,78	6,99	7,26
24°C D 17°C W	Total capacity kW	6,65	6,59	6,53	6,40	5,12	4,80
	Sensitive capacity kW	5,32	5,27	5,22	5,12	4,09	3,84
	Input kW.	2,63	2,61	2,59	2,54	2,61	2,71
27°C D 19°C W	Total capacity kW	7,31	7,24	7,17	7,03	5,62	5,27
	Sensitive capacity kW	5,85	5,79	5,74	5,62	4,50	4,22
	Input kW.	2,69	2,67	2,65	2,60	2,68	2,78
32°C D 23°C W	Total capacity kW	8,19	8,11	8,03	7,87	6,30	5,91
	Sensitive capacity kW	6,55	6,49	6,42	6,30	5,04	4,72
	Input kW.	3,01	2,99	2,97	2,91	3,00	3,12

HEATING		OUTDOOR CONDITIONS						
Indoor Conditions		24°C D 18°C W	12°C D 11°C W	7°C D 6°C W	4°C D 3°C W	0°C D -1°C W	-5°C D -6°C W	-7°C D -8°C W
15°C	Capacity kW	9,77	9,66	8,46	6,94	5,92	4,65	4,31
	Input kW.	3,07	3,04	2,66	2,46	2,40	2,12	2,06
18°C	Capacity kW	9,33	9,22	8,08	6,62	5,65	4,44	4,12
	Input kW.	2,93	2,90	2,54	2,35	2,29	2,02	1,97
20°C	Capacity kW	8,80	8,70	7,62	6,25	5,33	4,19	3,89
	Input kW.	2,77	2,74	2,40	2,22	2,17	1,91	1,86
22°C	Capacity kW	7,48	7,40	6,48	5,31	4,53	3,56	3,30
	Input kW.	2,56	2,53	2,21	2,05	2,00	1,76	1,71
27°C	Capacity kW	7,48	7,40	6,48	5,31	4,53	3,56	3,30
	Input kW.	2,58	2,55	2,23	2,07	2,02	1,78	1,73

5.2. MCD-24HRN1-Q1 / MOCA30U-24HN1-Q

COOLING		OUTDOOR TEMPERATURE DRY					
Indoor Conditions		21°C	25°C	30°C	35°C	40°C	45°C
21°C D 15°C W	Total capacity kW	4,96	4,91	4,87	4,77	3,82	3,58
	Sensitive capacity kW	3,97	3,93	3,89	3,82	3,05	2,86
	Input kW.	5,35	5,32	5,28	5,17	5,33	5,53
24°C D 17°C W	Total capacity kW	5,07	5,02	4,98	4,88	3,90	3,66
	Sensitive capacity kW	4,06	4,02	3,98	3,90	3,12	2,93
	Input kW.	2,00	1,99	1,97	1,93	1,99	2,07
27°C D 19°C W	Total capacity kW	5,57	5,52	5,47	5,36	4,29	4,02
	Sensitive capacity kW	4,46	4,42	4,37	4,29	3,43	3,22
	Input kW.	2,05	2,04	2,02	1,98	2,04	2,12
32°C D 23°C W	Total capacity kW	6,24	6,18	6,12	6,00	4,80	4,50
	Sensitive capacity kW	4,99	4,95	4,90	4,80	3,84	3,60
	Input kW.	2,30	2,28	2,26	2,22	2,28	2,37

HEATING		OUTDOOR CONDITIONS						
Indoor Conditions		24°C D 18°C W	12°C D 11°C W	7°C D 6°C W	4°C D 3°C W	0°C D -1°C W	-5°C D -6°C W	-7°C D -8°C W
15°C	Capacity kW	7,14	7,06	6,18	5,07	4,33	3,40	3,15
	Input kW.	2,20	2,18	1,91	1,76	1,72	1,52	1,48
18°C	Capacity kW	6,82	6,74	5,90	4,84	4,13	3,25	3,01
	Input kW.	2,10	2,08	1,82	1,69	1,64	1,45	1,41
20°C	Capacity kW	6,43	6,36	5,57	4,57	3,90	3,06	2,84
	Input kW.	1,99	1,96	1,72	1,59	1,55	1,37	1,33
22°C	Capacity kW	5,47	5,41	4,73	3,88	3,31	2,60	2,41
	Input kW.	1,83	1,81	1,59	1,47	1,43	1,26	1,23
27°C	Capacity kW	5,47	5,41	4,73	3,88	3,31	2,60	2,41
	Input kW.	1,85	1,83	1,60	1,48	1,45	1,27	1,24

5.3. MCD-36HRN1-R1 / MOD31U-36HN1-R

COOLING		OUTDOOR TEMPERATURE DRY					
Indoor Conditions		21°C	25°C	30°C	35°C	40°C	45°C
21°C D 15°C W	Total capacity kW	9,77	9,67	9,58	9,39	7,51	7,04
	Sensitive capacity kW	7,81	7,74	7,66	7,51	6,01	5,63
	Input kW.	10,54	10,47	10,38	10,18	10,49	10,89
24°C D 17°C W	Total capacity kW	9,98	9,89	9,79	9,60	7,68	7,20
	Sensitive capacity kW	7,99	7,91	7,83	7,68	6,14	5,76
	Input kW.	3,63	3,61	3,58	3,51	3,62	3,76
27°C D 19°C W	Total capacity kW	10,97	10,87	10,76	10,55	8,44	7,91
	Sensitive capacity kW	8,78	8,69	8,61	8,44	6,75	6,33
	Input kW.	3,73	3,70	3,67	3,60	3,71	3,85
32°C D 23°C W	Total capacity kW	12,29	12,17	12,05	11,82	9,45	8,86
	Sensitive capacity kW	9,83	9,74	9,64	9,45	7,56	7,09
	Input kW.	4,17	4,14	4,11	4,03	4,15	4,31

HEATING		OUTDOOR CONDITIONS						
Indoor Conditions		24°C D 18°C W	12°C D 11°C W	7°C D 6°C W	4°C D 3°C W	0°C D -1°C W	-5°C D -6°C W	-7°C D -8°C W
15°C	Capacity kW	13,53	13,37	11,71	9,60	8,20	6,44	5,97
	Input kW.	4,67	4,62	4,04	3,74	3,65	3,22	3,13
18°C	Capacity kW	12,92	12,77	11,18	9,17	7,83	6,15	5,70
	Input kW.	4,46	4,41	3,86	3,58	3,49	3,07	2,99
20°C	Capacity kW	12,19	12,05	10,55	8,65	7,39	5,80	5,38
	Input kW.	4,22	4,17	3,65	3,38	3,30	2,91	2,83
22°C	Capacity kW	10,36	10,24	8,97	7,35	6,28	4,93	4,57
	Input kW.	3,89	3,84	3,37	3,12	3,04	2,68	2,61
27°C	Capacity kW	10,36	10,24	8,97	7,35	6,28	4,93	4,57
	Input kW.	3,92	3,88	3,40	3,15	3,07	2,70	2,63

5.4. MCD-48HRN1-R / MOU-48HN1-R

COOLING		OUTDOOR TEMPERATURE DRY					
Indoor Conditions		21°C	25°C	30°C	35°C	40°C	45°C
21°C D 15°C W	Total capacity kW	13,02	12,90	12,77	12,52	10,02	9,39
	Sensitive capacity kW	10,42	10,32	10,22	10,02	8,01	7,51
	Input kW.	14,05	13,96	13,85	13,58	13,98	14,53
24°C D 17°C W	Total capacity kW	13,31	13,19	13,06	12,80	10,24	9,60
	Sensitive capacity kW	10,65	10,55	10,45	10,24	8,19	7,68
	Input kW.	5,24	5,21	5,17	5,06	5,22	5,42
27°C D 19°C W	Total capacity kW	14,63	14,49	14,35	14,07	11,25	10,55
	Sensitive capacity kW	11,70	11,59	11,48	11,25	9,00	8,44
	Input kW.	5,37	5,34	5,29	5,19	5,35	5,55
32°C D 23°C W	Total capacity kW	16,39	16,23	16,07	15,76	12,60	11,82
	Sensitive capacity kW	13,11	12,98	12,86	12,60	10,08	9,45
	Input kW.	6,02	5,98	5,93	5,81	5,99	6,22

HEATING		OUTDOOR CONDITIONS						
Indoor Conditions		24°C D 18°C W	12°C D 11°C W	7°C D 6°C W	4°C D 3°C W	0°C D -1°C W	-5°C D -6°C W	-7°C D -8°C W
15°C	Capacity kW	19,54	19,32	16,92	13,87	11,84	9,30	8,63
	Input kW.	6,10	6,03	5,28	4,89	4,77	4,20	4,09
18°C	Capacity kW	18,66	18,45	16,15	13,25	11,31	8,89	8,24
	Input kW.	5,82	5,75	5,04	4,67	4,55	4,01	3,91
20°C	Capacity kW	17,60	17,40	15,24	12,50	10,67	8,38	7,77
	Input kW.	5,50	5,44	4,76	4,41	4,30	3,79	3,69
22°C	Capacity kW	14,96	14,79	12,95	10,62	9,07	7,12	6,61
	Input kW.	5,07	5,02	4,39	4,07	3,97	3,50	3,40
27°C	Capacity kW	14,96	14,79	12,95	10,62	9,07	7,12	6,61
	Input kW.	5,12	5,06	4,43	4,11	4,00	3,53	3,44

5.5. MCD-60HRN1-R / MOUA-60HN1-R

COOLING		OUTDOOR TEMPERATURE DRY					
Indoor Conditions		21°C	25°C	30°C	35°C	40°C	45°C
21°C D 15°C W	Total capacity kW	14,92	14,78	14,63	14,35	11,48	10,76
	Sensitive capacity kW	11,94	11,82	11,71	11,48	9,18	8,61
	Input kW.	16,10	15,99	15,87	15,56	16,02	16,64
24°C D 17°C W	Total capacity kW	15,26	15,11	14,96	14,67	11,74	11,00
	Sensitive capacity kW	12,20	12,09	11,97	11,74	9,39	8,80
	Input kW.	6,33	6,29	6,24	6,12	6,30	6,55
27°C D 19°C W	Total capacity kW	16,76	16,60	16,44	16,12	12,90	12,09
	Sensitive capacity kW	13,41	13,28	13,15	12,90	10,32	9,67
	Input kW.	6,49	6,45	6,40	6,27	6,46	6,71
32°C D 23°C W	Total capacity kW	18,78	18,60	18,42	18,05	14,44	13,54
	Sensitive capacity kW	15,02	14,88	14,73	14,44	11,55	10,83
	Input kW.	7,27	7,22	7,17	7,02	7,24	7,52

HEATING		OUTDOOR CONDITIONS						
Indoor Conditions		24°C D 18°C W	12°C D 11°C W	7°C D 6°C W	4°C D 3°C W	0°C D -1°C W	-5°C D -6°C W	-7°C D -8°C W
15°C	Capacity kW	22,92	22,66	19,84	16,27	13,89	10,91	10,12
	Input kW.	7,48	7,39	6,47	5,99	5,85	5,15	5,02
18°C	Capacity kW	21,89	21,64	18,95	15,54	13,27	10,42	9,66
	Input kW.	7,14	7,06	6,18	5,72	5,58	4,92	4,79
20°C	Capacity kW	20,65	20,42	17,88	14,66	12,51	9,83	9,12
	Input kW.	6,75	6,67	5,84	5,41	5,28	4,65	4,53
22°C	Capacity kW	17,55	17,35	15,20	12,46	10,64	8,36	7,75
	Input kW.	6,22	6,15	5,39	4,99	4,86	4,29	4,18
27°C	Capacity kW	17,55	17,35	15,20	12,46	10,64	8,36	7,75
	Input kW.	6,28	6,21	5,44	5,04	4,91	4,33	4,22

6. Wiring Diagrams

MCD-18HRN1-Q1

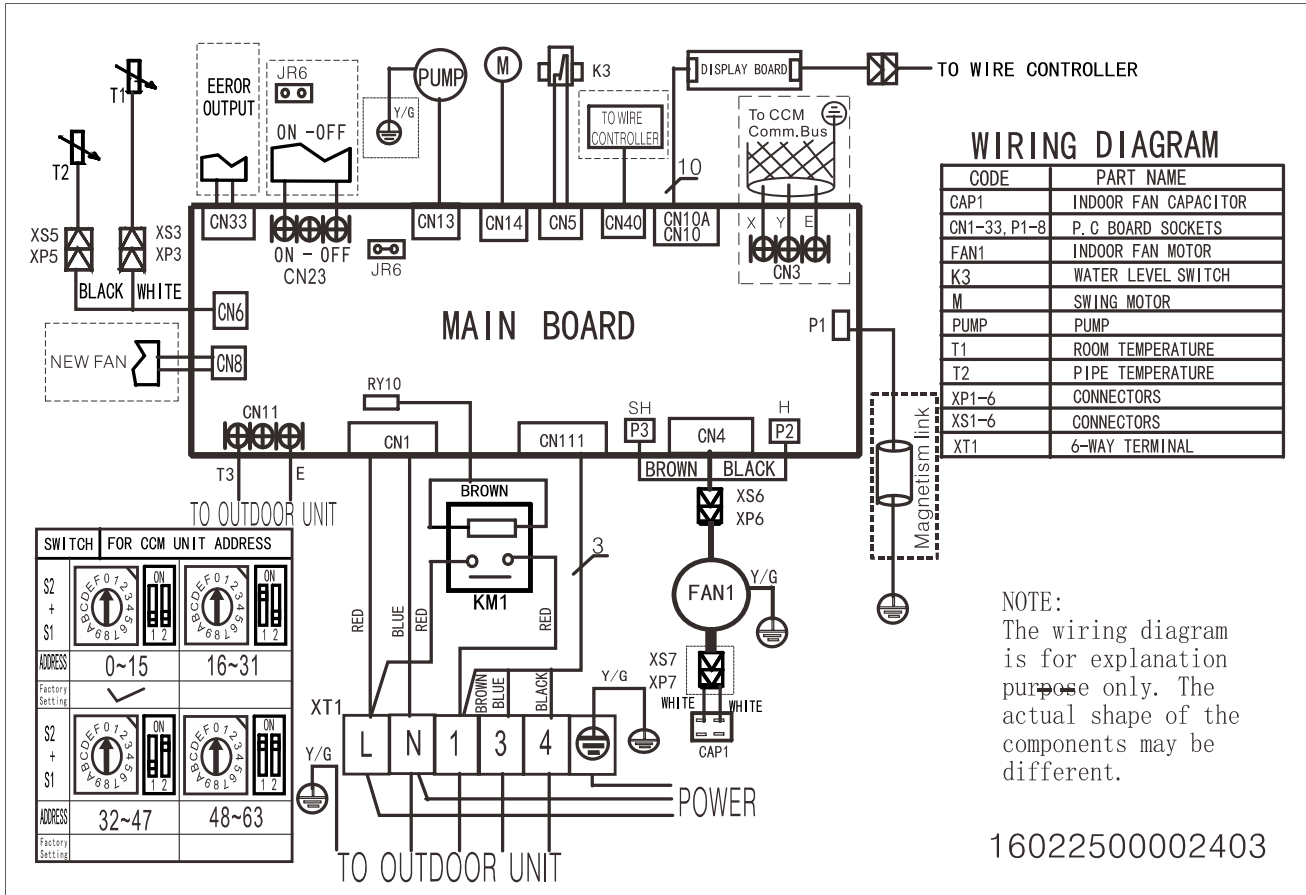

MCD-24HRN1-Q1

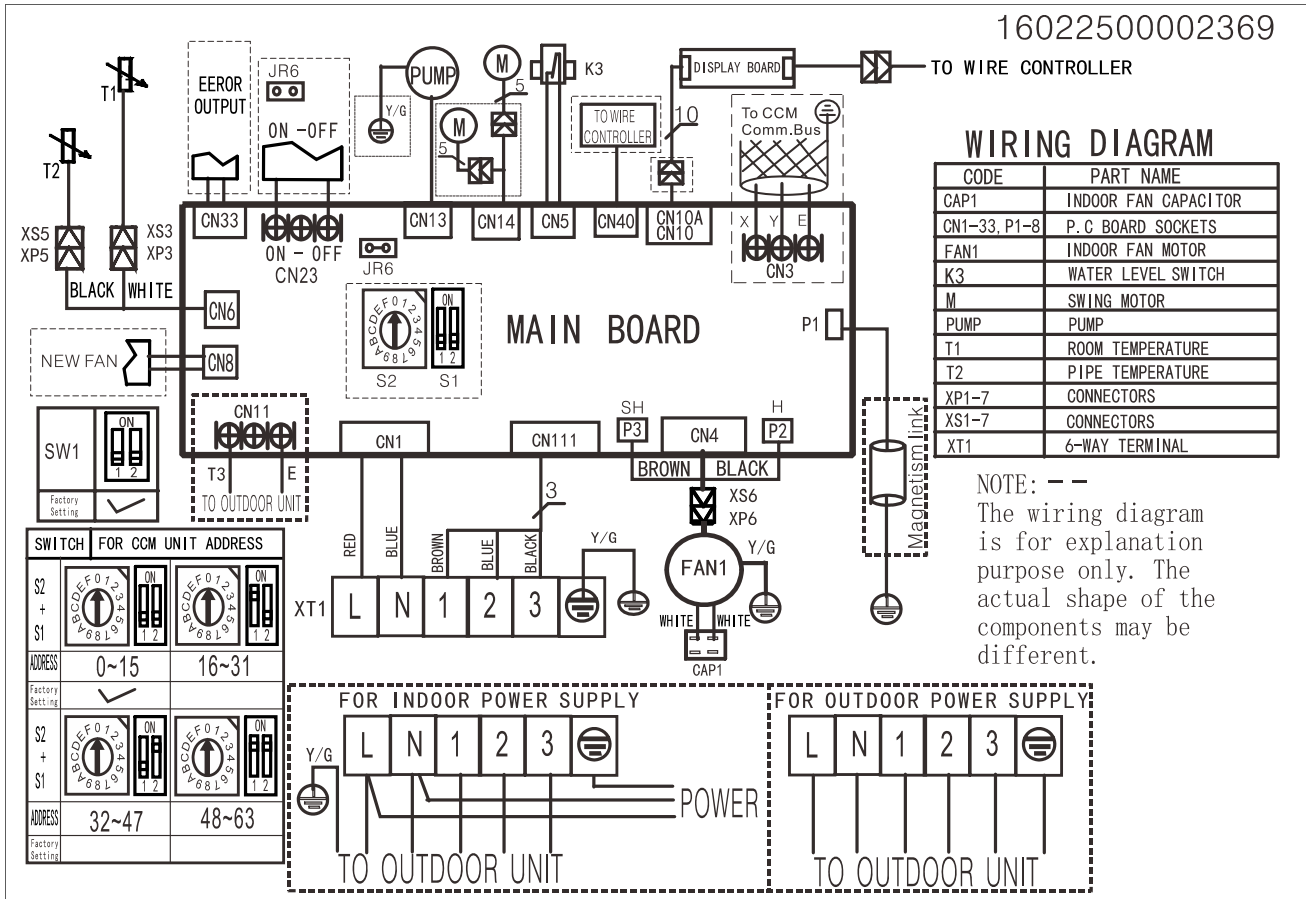

MCD-36HRN1-R1

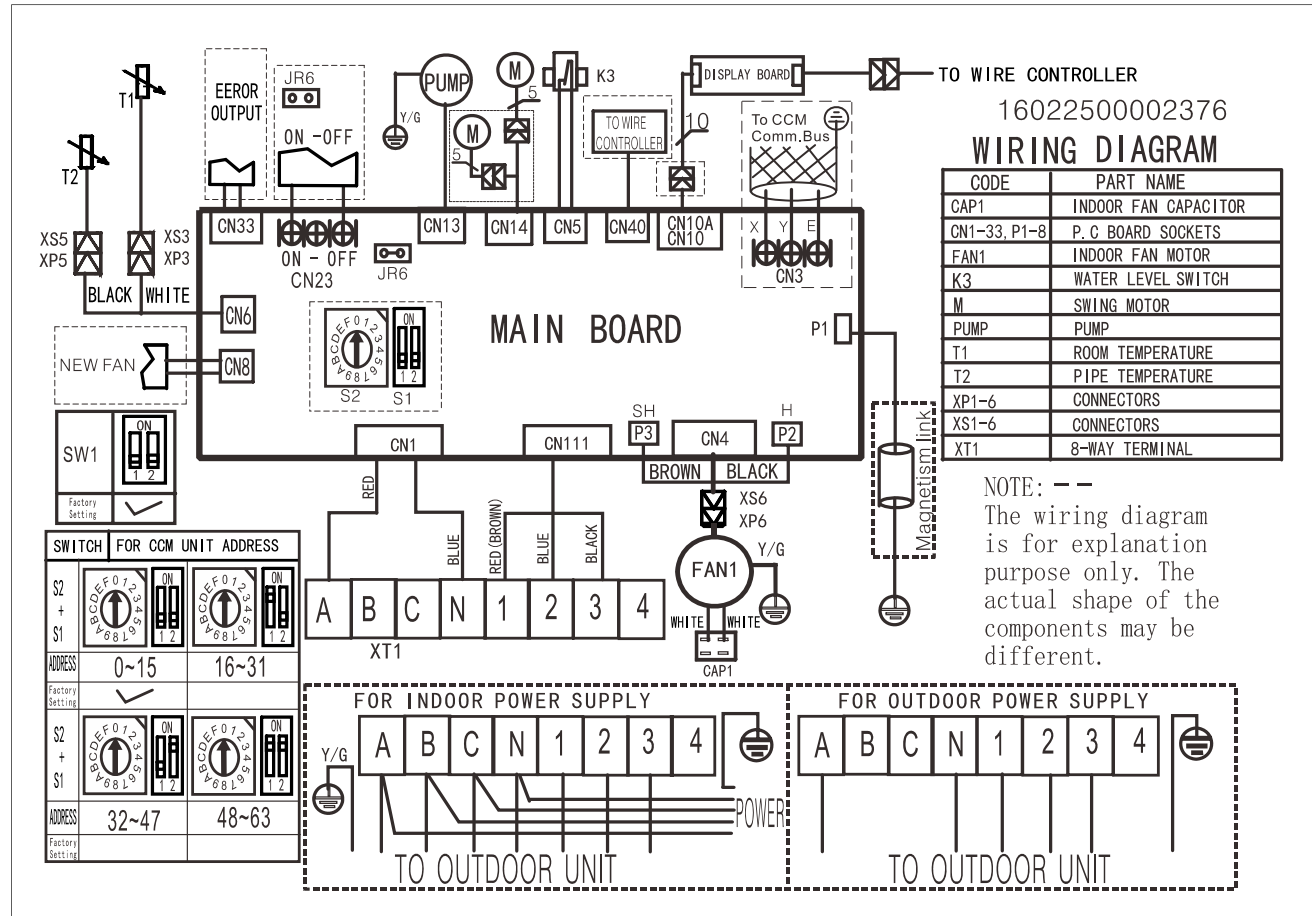

MCD-48HRN1-R, MCD-60HRN1-R

16022500000831

INDOOR WIRING DIAGRAM

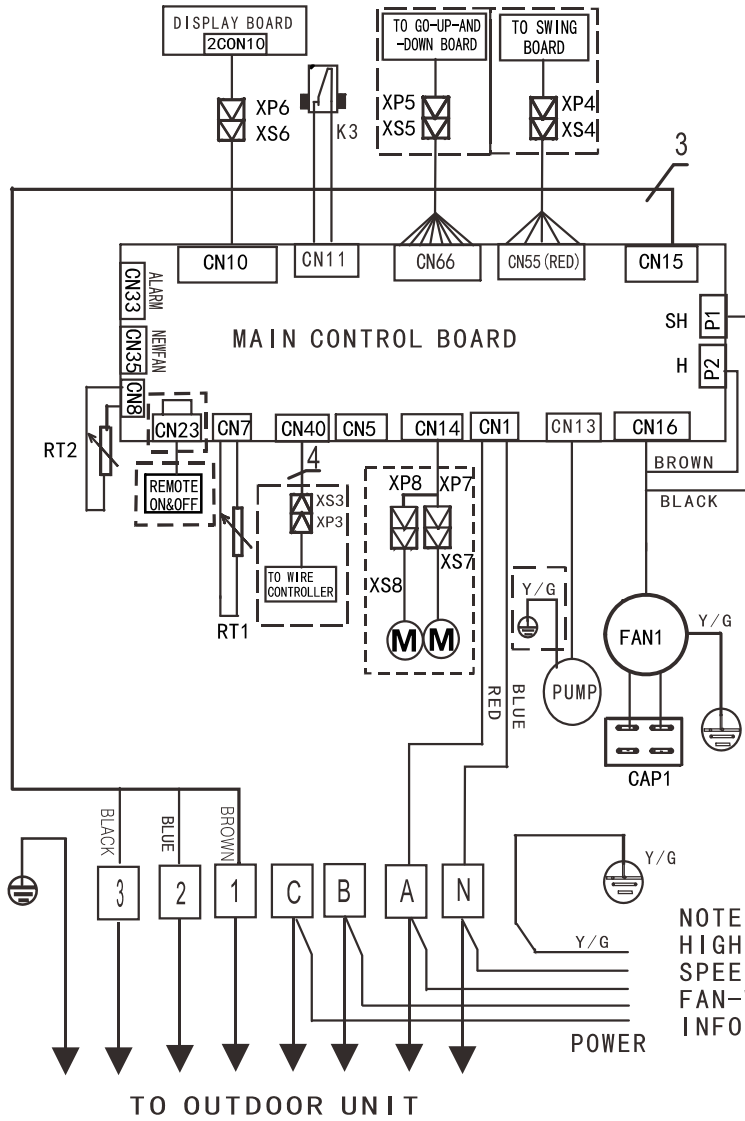

CODE	NAME
CAP1	INDOOR FAN CAPACITOR
CN1-66	P. C. B SOCKETS
FAN1	INDOOR FAN
K3	WATER LEVEL SWITCH
M	SWING MOTOR
PUMP	PUMP
RT1	ROOM TEMP. SENSOR
RT2	PIPE TEMP. SENSOR
XP3-XP8	CONNECTOR
XS3-XS8	CONNECTOR
P1	SUPER HIGH SPEED
P2	HIGH SPEED

NOTE: FOR FAN OPERATES IN SUPER HIGH SPEED, PLEASE SWITCH HIGH SPEED TO SUPER HIGH SPEED, SEE FAN-WIRING PART FOR DETAIL INFORMATION!

7. Electric Characteristics

Model	Indoor Unit				Power Supply
	Hz	Voltage	Min	Max	MFA
MCD-18HRN1-Q1	50	220-240V	198V	254V	20
MCD-24HRN1-Q1	50	220-240V	198V	254V	25
MCD-36HRN1-R1	50	220-240V	198V	254V	/
MCD-48HRN1-R	50	380-415V	342V	436V	25
MCD-60HRN1-R	50	380-415V	342V	436V	25

Notes:

MFA: Max. Fuse Amps. (A)

8. Sound Levels

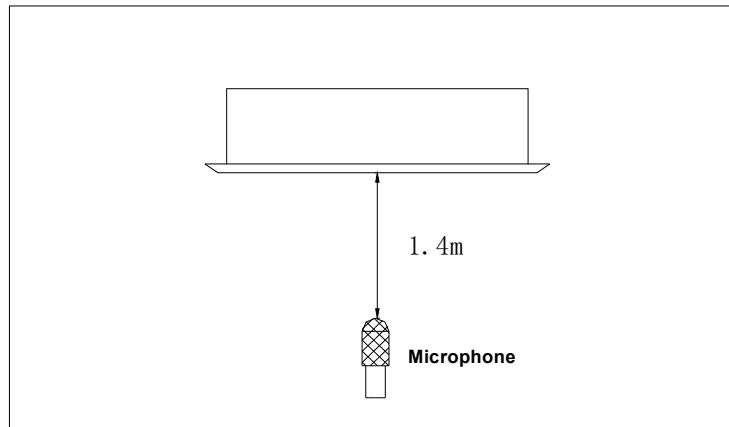

Model	Noise level dB(A)		
	H	M	L
MCD-18HRN1-Q1	43	40	35
MCD-24HRN1-Q1	50	45	41
MCD-36HRN1-R1	52	48	45
MCD-48HRN1-R	53	48	44
MCD-60HRN1-R	53	48	44

9. The Specification of Power

Model (KBtu/h)		18	24	36	48~60
Power	Phase	1-phase	1-phase	3-phase	3-phase
	Frequency and Voltage	220-240V, 50Hz		380-415V, 50Hz	
Circuit Breaker/ Fuse (A)		25/20	32/25	25/20	32/25
Indoor Unit Power Wiring (mm ²)		3×2.5	3×2.5	3×1.5	5×2.5
Indoor/Outdoor Wiring (mm ²)	Connecting				
	Ground Wiring	2.5	2.5	2.5	2.5
	Outdoor Unit Power Wiring	3×2.5	3×2.5	5×2.5	5×2.5
	Strong Electric Signal	2×1.0	3×1.0	3×1.0	3×1.0
	Weak Electric Signal	(2×0.75/ 2×0.5)	(2×0.2)	—————	—————

10. Field Wiring

MCD-18HRN1-Q1

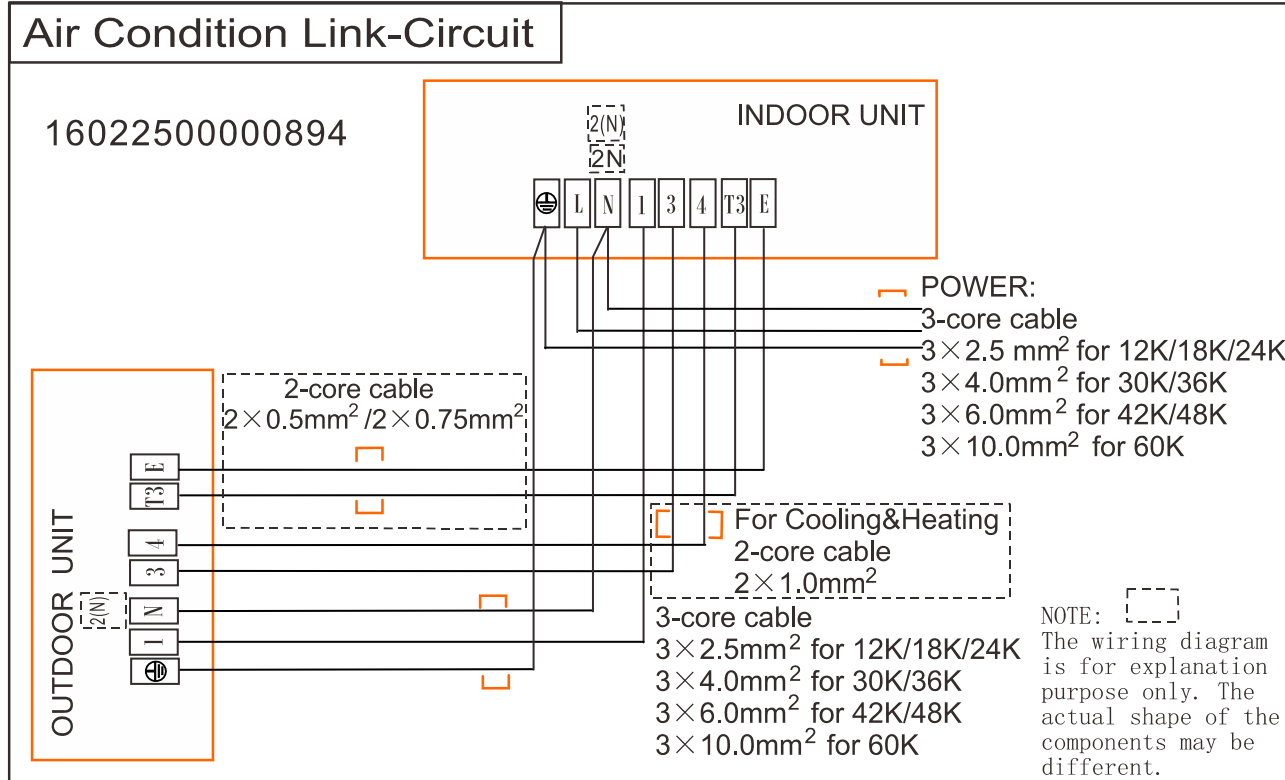

MCD-24HRN1-Q1

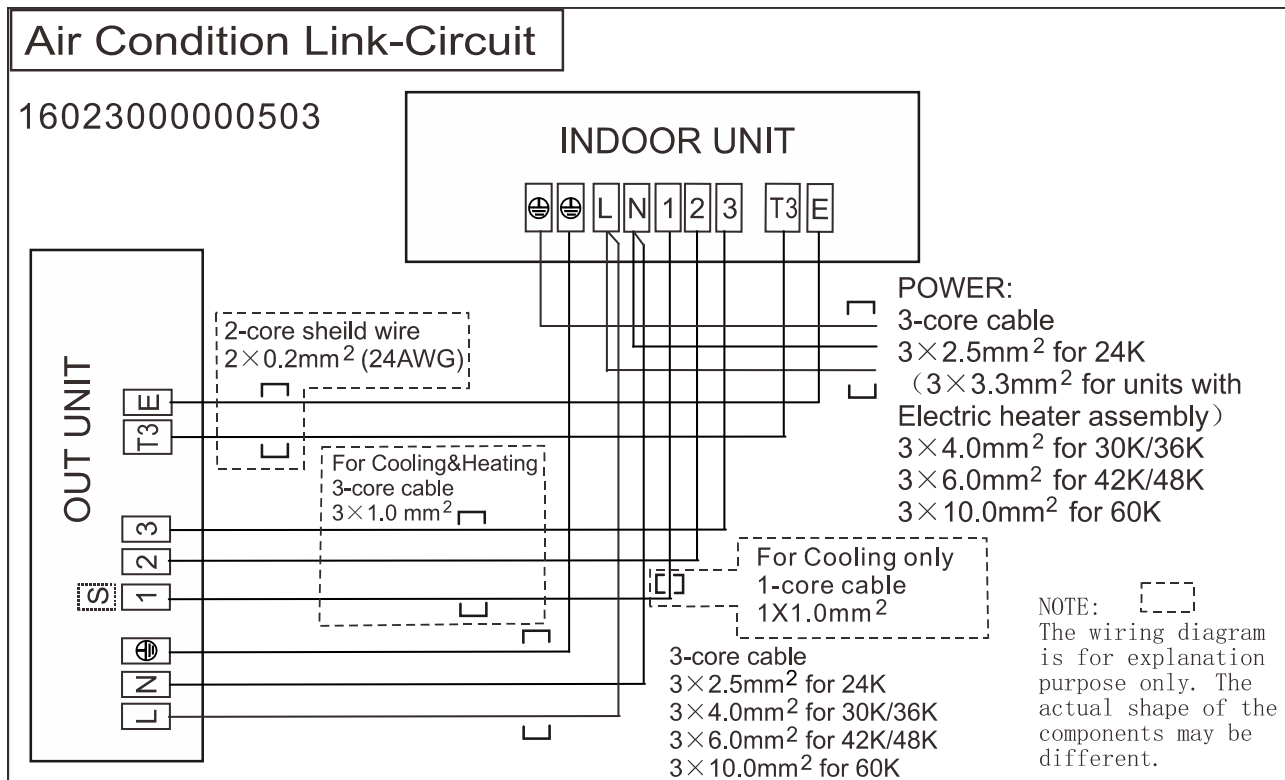

MCD-36HRN1-R1

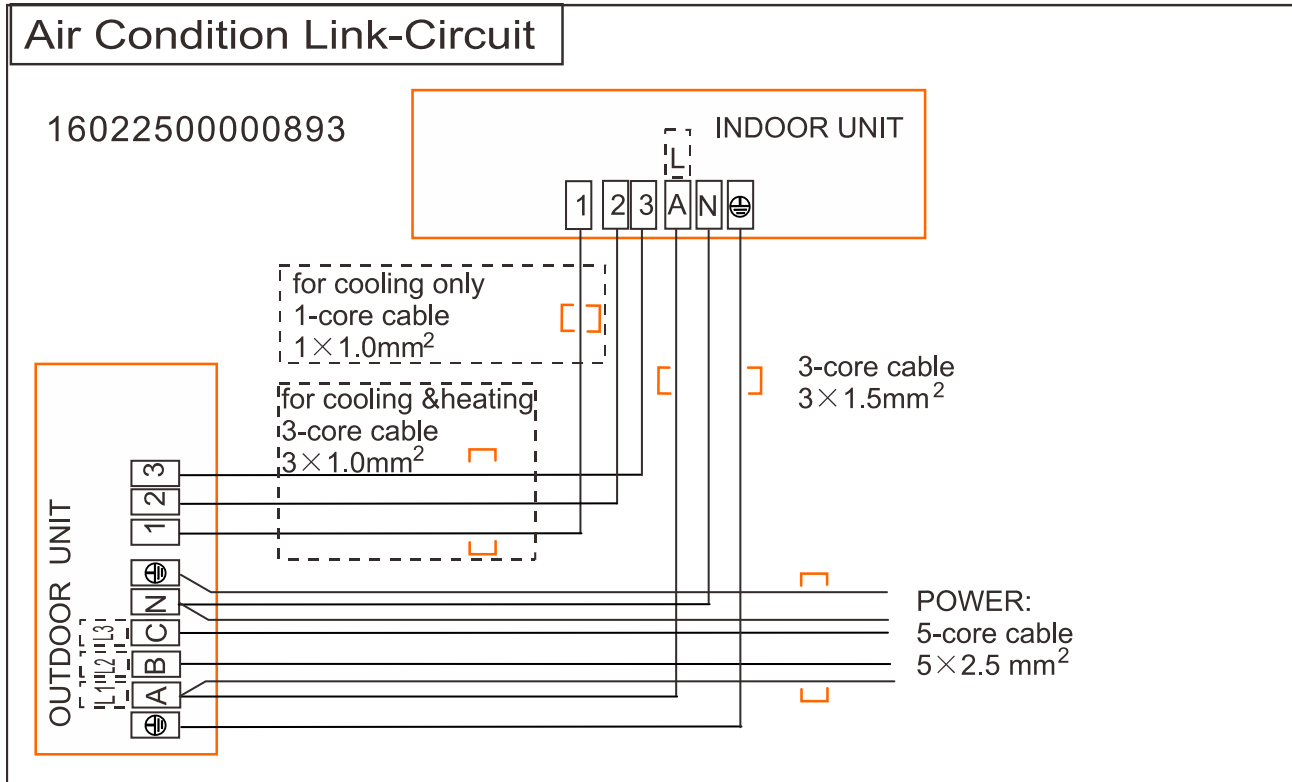

MCD-48HRN1-R, MCD-60HRN1-R

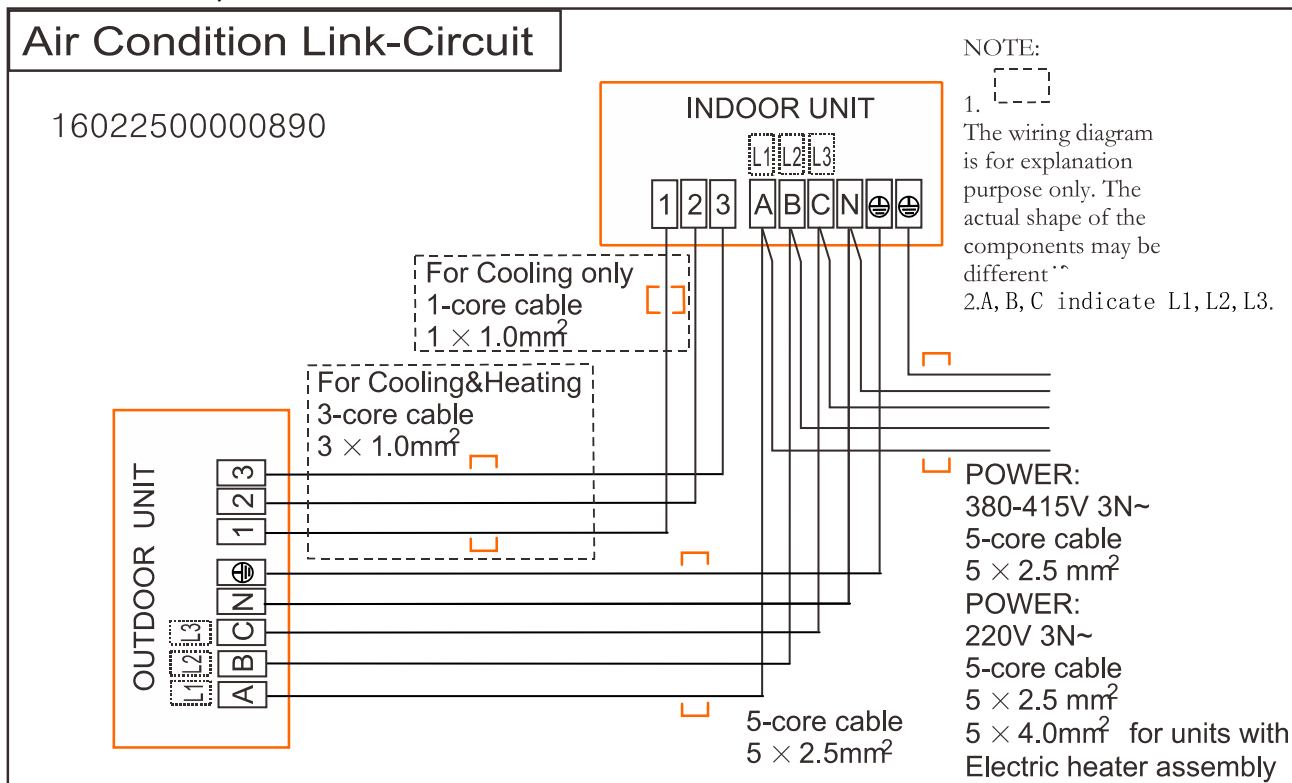

MSP Duct Type

1. Features.....	44
2. Specification.....	46
3. Dimensions.....	46
4. Service Space.....	49
5. Capacity tables.....	50
6. Wiring Diagrams	55
7. Static Pressure	57
8. Electric Characteristics	60
9. Sound Levels.....	61
10. The Specification of Power	62
11. Field Wiring.....	63

1. Features

1.1 Easy Installation: Two air inlet styles (Bottom side or Rear side)

- Air inlet from rear is standard for all capacity; air inlet from bottom is optional.
- The size of air inlet frame from rear and bottom is same, it's very easy to move the cover from bottom to rear side, or from rear to the bottom, in order to matching the installation condition.

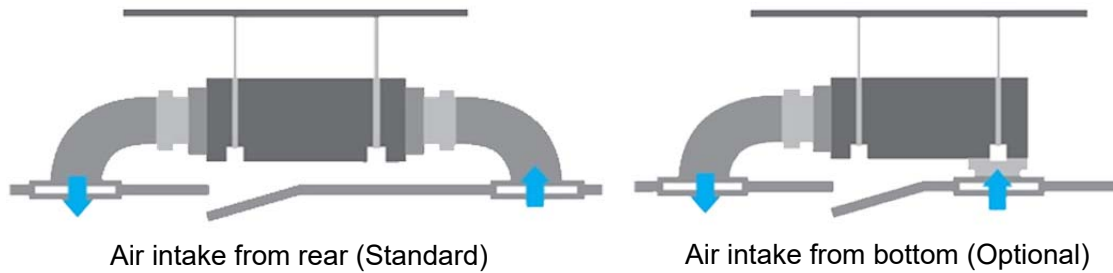

1.2 Slim Design

- The industry Lowest height is designed to be fitted into tight roof spaces.

36K unit -300mm

1.3 Easy maintenance

- Clean the filter (Optional, standard product without filter)
It is easy to draw out the filter from the indoor unit for cleaning, even the filter is installed in rear side or bottom side.

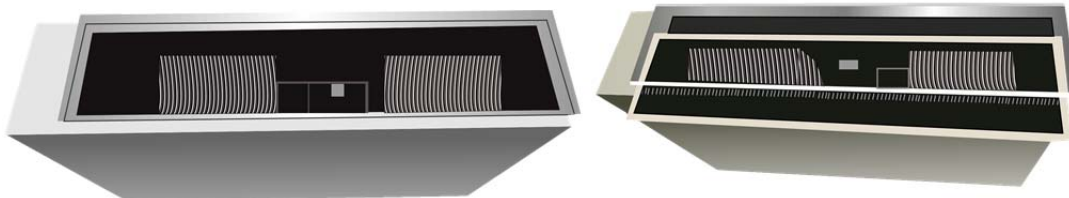

- Replace the motor or centrifugal fan
Remove the ventilated panel firstly. Remove a half of blower housing and take out the motor with centrifugal fan. Directly remove two bolts, and then replace the motor or centrifugal fan easily.

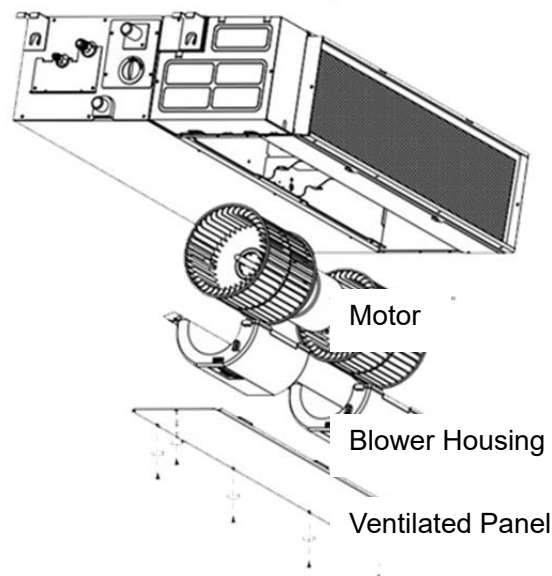

1.4 Reserved remote on-off and central control ports

- Reserved remote on-off ports and central control ports, can connect the cable of an on-off controller or a central controller to realize remote on-off control function or group control function.

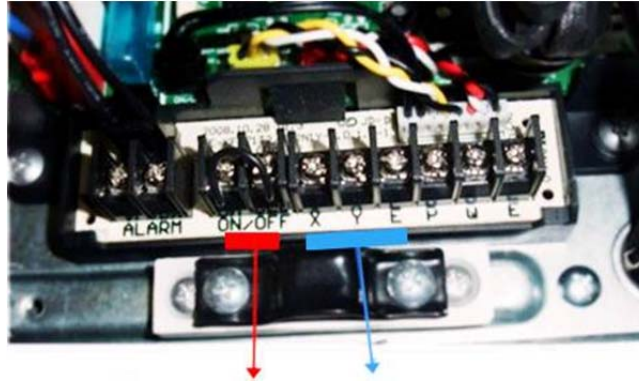

Remote on-off ports Central control ports

1.4 Built-in display board

- The standard indoor unit can be controlled by wired controller.
- There is a display board with a receiver in the E-box. Move out the display, and fix it in other place, even in the distance of 2m. The unit will realized remoter control.
- The wired controller and the display board can display the error code or production code when the chips detect some failure.

Wired Controller (Standard)

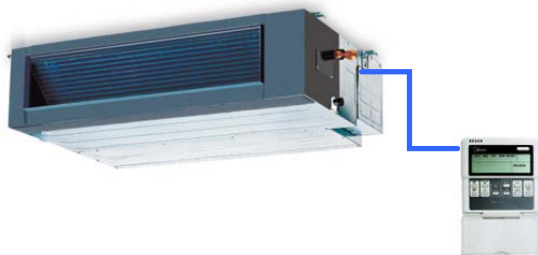

Remote Controller (Optional)

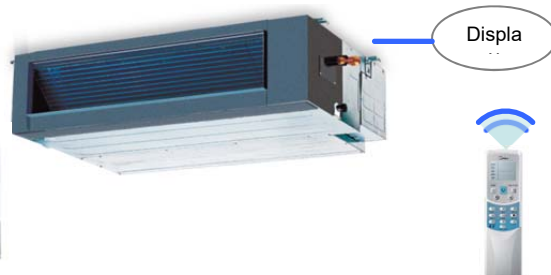

2. Specification

Indoor model			MTB-18HWN1-Q1	MTB-24HWN1-Q1
Outdoor model			MOBA30U-18HN1-Q	MOCA30U-24HN1-Q
Power supply		V-ph-Hz	220-240-1-50	220-240-1-50
Cooling	Capacity	Btu/h	18000	24000
		kW	5.28	7.03
	Input	W	2130	2650
	Current	A	8,82	12,72
EER	W/W	2,48	2,65	
Heating	Capacity	Btu/h	19000	26000
		kW	5.57	7.62
	Input	W	1760	2500
	Current	A	7,8	12
COP	W/W	3,16	3,05	
Indoor fan motor	Model		YKSS-68-4-15-1	YKSS-74-4-16-1
	Qty		1	1
	Input	W	107/65/52	163/93/75
	Capacitor	uF	3.5UF/450V	3.5UF/450V
	Speed(Hi/Med/Lo)	r/min	1150/800/700	1000/750/680
Indoor coil	Number of rows		3	3
	Tube pitch(a)*row pitch(b)	mm	21x13.37	21x13.37
	Fin spacing	mm	1.5	1.4
	Fin type		Hydrophilic aluminium	Hydrophilic aluminium
	Tube outside dia.and type	mm	Φ7,innergroove tube	Φ7,innergroove tube
	Coil length * height * width	mm	733x252x40.11	733x252x40.11
Number of circuits		4	6	
Indoor air flow (Hi/Med/Lo)		m ³ /h	816/546/-	1260/808/-
ESP	Rated	Pa	25	25
	Range	Pa	0-60	0-80
Indoor noise level (Hi/Med/Lo)		dB(A)	43/37/36	45/40/38
Throttle type			/	/
Indoor unit	Dimension (WxDxH)	mm	920x635x210	920x635x270
	Packing(WxDxH)	mm	1135x655x290	1150x655x350
	Net/Gross weight	kg	24/28	26.5/32
Design pressure		MPa	4.2/1.5	4.2/1.5
Drainage water pipe diameter		mm	0DΦ25	0DΦ25
Refrigerant piping	Liquid side/ Gas side	mm	Φ6.35/Φ12.7(1/4"/1/2")	Φ9.52Φ15.9(3/8"/5/8")
Controller			KJR-12B/DP(T)-E-2	KJR-12B/DP(T)-E-2
Operation temperature		°C	17~30	17~30
Room temperature	Cooling	°C	17~32	17~32
	Heating	°C	0~30	0~30

Indoor model			MTI-36HWN1-R1	MTB-48HWN1-R	MTB-60HWN1-R
Outdoor model			MOD31U-36HN1-R	MOU-48HN1-R	MOUA-60HN1-R
Power supply		V,Hz,Ph	380~415,50,3	380~420,50,3	380~420,50,3
Cooling	Capacity	Btu/h	36000	48000	55000
	Input	W	3654	5240	6225
	Current	A	6.12	7,60	10,90
	EER	W/W	2,89	2,68	2,59
Heating	Capacity	Btu/h	37000	55000	60000
	Input	W	3315	4400	5187
	Current	A	5.64	6,4	9,10
	COP	W/W	3,27	3,66	3,39
Indoor fan motor	Model		YKSS-115-4-21	YSK180-4P	YSK180-4P
	Qty		1	1	1
	Input	W	238/198/167	356/201/152	355/223/173
	Capacitor	uF	5	10UF/450V	10UF/450V
	Speed(Hi/Med/Lo)	r/min	860/830/730	1070/750/650	1080/830/710
Indoor coil	Number of rows		3	3	4
	Tube pitch(a)*row pitch(b)	mm	21x13.37	21x13.37	21x13.37
	Fin spacing	mm	1.4	1.3	1,4
	Fin type		Hydrophilic aluminium	Hydrophilic aluminium	Hydrophilic aluminium
	Tube outside dia.and type	mm	Φ7, innergroove tube	Φ7,innergroove tube	Φ7,innergroove tube
	Coil length * height * width	mm	915x294x40.11	1030x378x53.48	1030x378x53.48
	Number of circuits		7	8	8
Indoor air flow (Hi/Med/Lo)		m ³ /h	1804/1372/1149	2282/1439/-	2275/-/-
ESP	Rated	Pa	37	50	50
	Range	Pa	0-100	0-100	0-120
Indoor noise level (Hi/Med/Lo)		dB(A)	48.7/43/40.6	50/45/40	47/40/38
Throttle type			/	/	/
Indoor unit	Dimension (WxDxH)	mm	1100x774x249	1200x865x300	1200x865x300
	Packing(WxDxH)	mm	1305x805x305	1405x920x373	1405x920x373
	Net/Gross weight	kg	32.2/39.4	44.5/53	47/55
Design pressure		MPa	4.2/1.5	4.2/1.5	4.2/1.5
Drainage water pipe diameter		mm	ODΦ25mm	ODΦ25	ODΦ25
Refrigerant piping	Liquid side/ Gas side	mm	Φ9.52/Φ19(3/8"/3/4")	Φ12.7/Φ19	Φ12.7/Φ19
Controller			KJR-12B/DP(T)-E-2	KJR-12B/DP(T)-E-2	KJR-12B/DP(T)-E-2
Operation temperature		°C	17~30	17~30	17~30
Room temperature	Cooling	°C	17~32	17~32	17~32
	Heating	°C	0~30	0~30	0~30

3. Dimensions

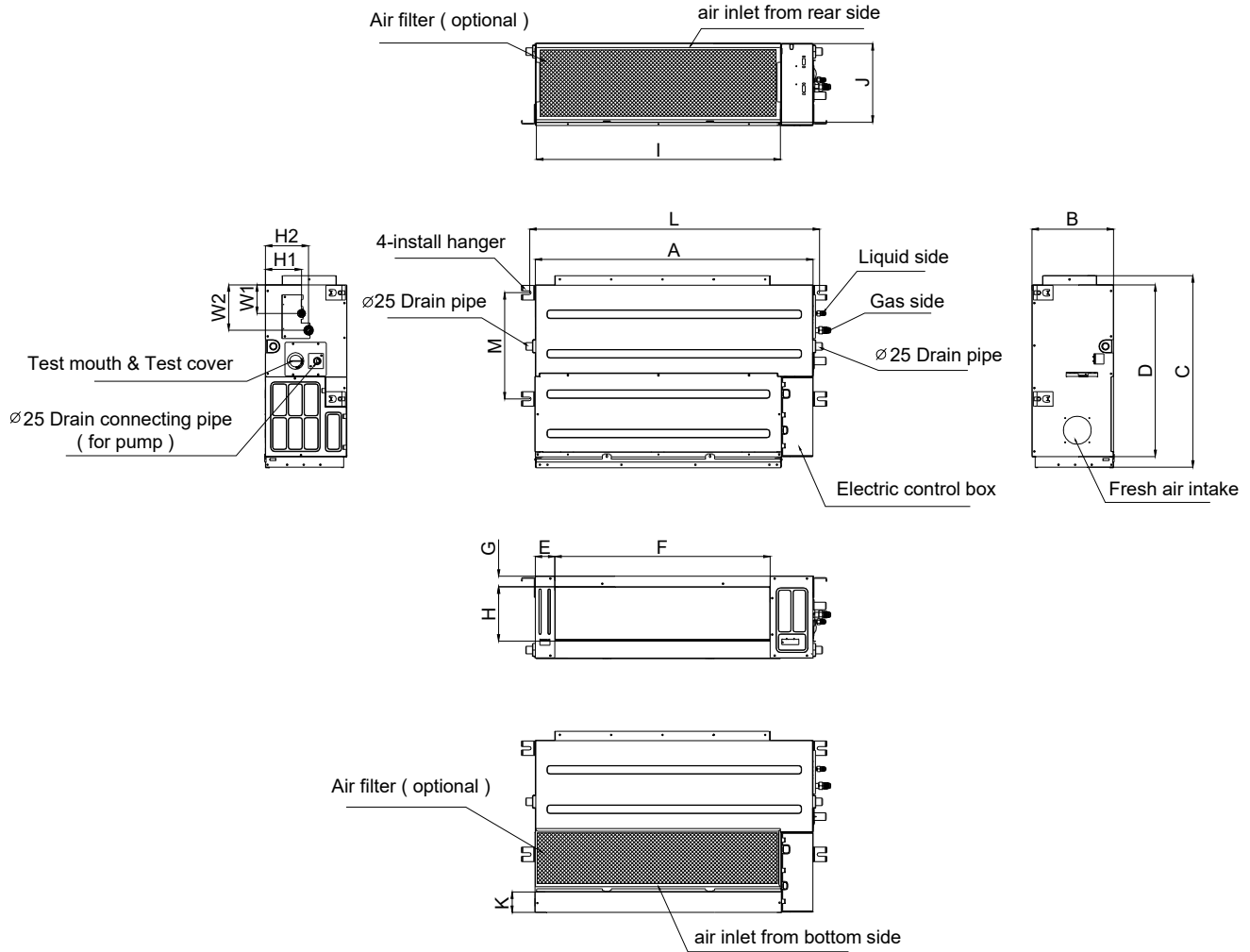

Note: standard product without filter

Model(Btu/h)	Outline dimension(mm)				Air outlet opening size				Air return opening size			Size of install hanger		Size of refrigerant pipe			
	A	B	C	D	E	F	G	H	I	J	K	L	M	H1	H2	W1	W2
	18K	920	210	635	570	65	713	35	119	815	200	80	960	350	120	143	95
24K	920	270	635	570	65	713	35	179	815	260	20	960	350	120	143	95	150
36K	1100	249	774	700	140	926	50	175	1001	228	5	1140	598	80	150	130	155
48K/60K	1200	300	865	800	80	968	40	204	1094	288	45	1240	500	175	198	155	210

Unit: mm

4. Service Space

Ensure enough space required for installation and maintenance.

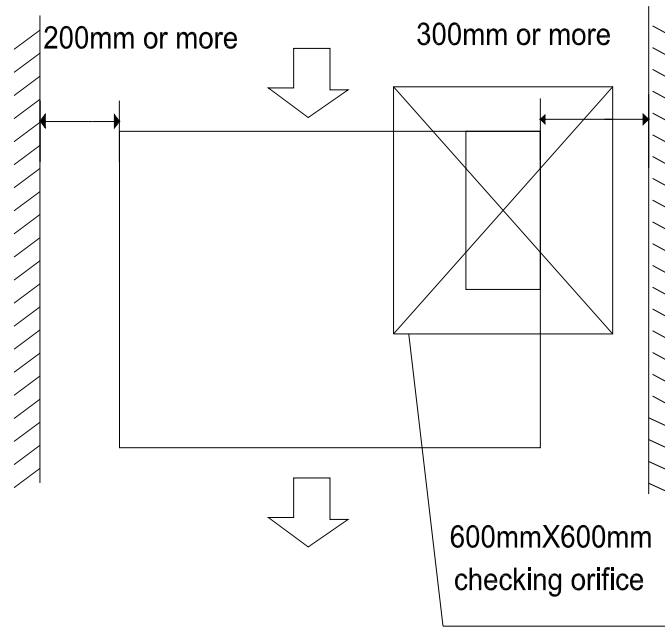

5. Capacity tables

5.1. MTB-18HWN1-Q1 / MOBA30U-18HN1-Q

COOLING		OUTDOOR TEMPERATURE DRY					
Indoor Conditions		21°C	25°C	30°C	35°C	40°C	45°C
21°C D 15°C W	Total capacity kW	4,89	4,84	4,79	4,70	3,76	3,52
	Sensitive capacity kW	3,91	3,87	3,83	3,76	3,01	2,82
	Input kW.	5,27	5,24	5,20	5,10	5,25	5,45
24°C D 17°C W	Total capacity kW	5,00	4,95	4,90	4,80	3,84	3,60
	Sensitive capacity kW	4,00	3,96	3,92	3,84	3,08	2,88
	Input kW.	2,15	2,14	2,12	2,08	2,14	2,22
27°C D 19°C W	Total capacity kW	5,49	5,44	5,39	5,28	4,22	3,96
	Sensitive capacity kW	4,39	4,35	4,31	4,22	3,38	3,17
	Input kW.	2,20	2,19	2,17	2,13	2,19	2,28
32°C D 23°C W	Total capacity kW	6,15	6,09	6,03	5,91	4,73	4,44
	Sensitive capacity kW	4,92	4,87	4,83	4,73	3,78	3,55
	Input kW.	2,47	2,45	2,43	2,39	2,46	2,55

HEATING		OUTDOOR CONDITIONS						
Indoor Conditions		24°C D 18°C W	12°C D 11°C W	7°C D 6°C W	4°C D 3°C W	0°C D -1°C W	-5°C D -6°C W	-7°C D -8°C W
15°C	Capacity kW	7,14	7,06	6,18	5,07	4,33	3,40	3,15
	Input kW.	2,25	2,23	1,95	1,81	1,76	1,55	1,51
18°C	Capacity kW	6,82	6,74	5,90	4,84	4,13	3,25	3,01
	Input kW.	2,15	2,13	1,86	1,72	1,68	1,48	1,44
20°C	Capacity kW	6,43	6,36	5,57	4,57	3,90	3,06	2,84
	Input kW.	2,03	2,01	1,76	1,63	1,59	1,40	1,36
22°C	Capacity kW	5,47	5,41	4,73	3,88	3,31	2,60	2,41
	Input kW.	1,87	1,85	1,62	1,50	1,47	1,29	1,26
27°C	Capacity kW	5,47	5,41	4,73	3,88	3,31	2,60	2,41
	Input kW.	1,89	1,87	1,64	1,52	1,48	1,30	1,27

5.2. MTB-24HWN1-Q1 / MOCA30U-24HN1-Q

COOLING		OUTDOOR TEMPERATURE DRY					
Indoor Conditions		21°C	25°C	30°C	35°C	40°C	45°C
21°C D 15°C W	Total capacity kW	6,51	6,44	6,38	6,26	5,01	4,69
	Sensitive capacity kW	5,21	5,16	5,11	5,01	4,00	3,75
	Input kW.	7,02	6,97	6,92	6,78	6,99	7,26
24°C D 17°C W	Total capacity kW	6,65	6,59	6,53	6,40	5,12	4,80
	Sensitive capacity kW	5,32	5,27	5,22	5,12	4,09	3,84
	Input kW.	2,68	2,66	2,64	2,59	2,66	2,77
27°C D 19°C W	Total capacity kW	7,31	7,24	7,17	7,03	5,62	5,27
	Sensitive capacity kW	5,85	5,79	5,74	5,62	4,50	4,22
	Input kW.	2,74	2,72	2,70	2,65	2,73	2,84
32°C D 23°C W	Total capacity kW	8,19	8,11	8,03	7,87	6,30	5,91
	Sensitive capacity kW	6,55	6,49	6,42	6,30	5,04	4,72
	Input kW.	3,07	3,05	3,03	2,97	3,06	3,18

HEATING		OUTDOOR CONDITIONS						
Indoor Conditions		24°C D 18°C W	12°C D 11°C W	7°C D 6°C W	4°C D 3°C W	0°C D -1°C W	-5°C D -6°C W	-7°C D -8°C W
15°C	Capacity kW	9,77	9,66	8,46	6,94	5,92	4,65	4,31
	Input kW.	3,20	3,16	2,77	2,57	2,50	2,20	2,15
18°C	Capacity kW	9,33	9,22	8,08	6,62	5,65	4,44	4,12
	Input kW.	3,05	3,02	2,65	2,45	2,39	2,11	2,05
20°C	Capacity kW	8,80	8,70	7,62	6,25	5,33	4,19	3,89
	Input kW.	2,89	2,86	2,50	2,32	2,26	1,99	1,94
22°C	Capacity kW	7,48	7,40	6,48	5,31	4,53	3,56	3,30
	Input kW.	2,66	2,63	2,31	2,13	2,08	1,83	1,79
27°C	Capacity kW	7,48	7,40	6,48	5,31	4,53	3,56	3,30
	Input kW.	2,69	2,66	2,33	2,16	2,10	1,85	1,80

5.3. MTI-36HWN1-R1 / MOD31U-36HN1-R

COOLING		OUTDOOR TEMPERATURE DRY					
Indoor Conditions		21°C	25°C	30°C	35°C	40°C	45°C
21°C D 15°C W	Total capacity kW	9,77	9,67	9,58	9,39	7,51	7,04
	Sensitive capacity kW	7,81	7,74	7,66	7,51	6,01	5,63
	Input kW.	10,54	10,47	10,38	10,18	10,49	10,89
24°C D 17°C W	Total capacity kW	9,98	9,89	9,79	9,60	7,68	7,20
	Sensitive capacity kW	7,99	7,91	7,83	7,68	6,14	5,76
	Input kW.	3,69	3,66	3,64	3,56	3,67	3,81
27°C D 19°C W	Total capacity kW	10,97	10,87	10,76	10,55	8,44	7,91
	Sensitive capacity kW	8,78	8,69	8,61	8,44	6,75	6,33
	Input kW.	3,78	3,76	3,73	3,65	3,76	3,91
32°C D 23°C W	Total capacity kW	12,29	12,17	12,05	11,82	9,45	8,86
	Sensitive capacity kW	9,83	9,74	9,64	9,45	7,56	7,09
	Input kW.	4,24	4,21	4,17	4,09	4,22	4,38

HEATING		OUTDOOR CONDITIONS						
Indoor Conditions		24°C D 18°C W	12°C D 11°C W	7°C D 6°C W	4°C D 3°C W	0°C D -1°C W	-5°C D -6°C W	-7°C D -8°C W
15°C	Capacity kW	13,90	13,74	12,03	9,87	8,42	6,62	6,14
	Input kW.	4,24	4,19	3,67	3,40	3,32	2,92	2,85
18°C	Capacity kW	13,27	13,12	11,49	9,42	8,04	6,32	5,86
	Input kW.	4,05	4,01	3,51	3,25	3,17	2,79	2,72
20°C	Capacity kW	12,52	12,38	10,84	8,89	7,59	5,96	5,53
	Input kW.	3,83	3,79	3,32	3,07	2,99	2,64	2,57
22°C	Capacity kW	10,64	10,52	9,21	7,56	6,45	5,07	4,70
	Input kW.	3,53	3,49	3,06	2,83	2,76	2,43	2,37
27°C	Capacity kW	10,64	10,52	9,21	7,56	6,45	5,07	4,70
	Input kW.	3,56	3,52	3,09	2,86	2,79	2,46	2,39

5.4. MTB-48HWN1-R / MOU-48HN1-R

COOLING		OUTDOOR TEMPERATURE DRY					
Indoor Conditions		21°C	25°C	30°C	35°C	40°C	45°C
21°C D 15°C W	Total capacity kW	13,02	12,90	12,77	12,52	10,02	9,39
	Sensitive capacity kW	10,42	10,32	10,22	10,02	8,01	7,51
	Input kW.	14,05	13,96	13,85	13,58	13,98	14,53
24°C D 17°C W	Total capacity kW	13,31	13,19	13,06	12,80	10,24	9,60
	Sensitive capacity kW	10,65	10,55	10,45	10,24	8,19	7,68
	Input kW.	5,29	5,25	5,21	5,11	5,26	5,47
27°C D 19°C W	Total capacity kW	14,63	14,49	14,35	14,07	11,25	10,55
	Sensitive capacity kW	11,70	11,59	11,48	11,25	9,00	8,44
	Input kW.	5,42	5,39	5,34	5,24	5,40	5,61
32°C D 23°C W	Total capacity kW	16,39	16,23	16,07	15,76	12,60	11,82
	Sensitive capacity kW	13,11	12,98	12,86	12,60	10,08	9,45
	Input kW.	6,07	6,03	5,99	5,87	6,04	6,28

HEATING		OUTDOOR CONDITIONS						
Indoor Conditions		24°C D 18°C W	12°C D 11°C W	7°C D 6°C W	4°C D 3°C W	0°C D -1°C W	-5°C D -6°C W	-7°C D -8°C W
15°C	Capacity kW	20,67	20,43	17,89	14,67	12,52	9,84	9,13
	Input kW.	5,63	5,57	4,88	4,51	4,40	3,88	3,78
18°C	Capacity kW	19,74	19,51	17,09	14,01	11,96	9,40	8,71
	Input kW.	5,38	5,32	4,66	4,31	4,20	3,71	3,61
20°C	Capacity kW	18,62	18,41	16,12	13,22	11,28	8,87	8,22
	Input kW.	5,08	5,02	4,40	4,07	3,97	3,50	3,41
22°C	Capacity kW	15,83	15,65	13,70	11,24	9,59	7,54	6,99
	Input kW.	4,69	4,63	4,06	3,76	3,66	3,23	3,14
27°C	Capacity kW	15,83	15,65	13,70	11,24	9,59	7,54	6,99
	Input kW.	4,73	4,68	4,10	3,79	3,70	3,26	3,17

5.5. MTB-60HWN1-R / MOUA-60HN1-R

COOLING		OUTDOOR TEMPERATURE DRY					
Indoor Conditions		21°C	25°C	30°C	35°C	40°C	45°C
21°C D 15°C W	Total capacity kW	14,92	14,78	14,63	14,35	11,48	10,76
	Sensitive capacity kW	11,94	11,82	11,71	11,48	9,18	8,61
	Input kW.	16,10	15,99	15,87	15,56	16,02	16,64
24°C D 17°C W	Total capacity kW	15,26	15,11	14,96	14,67	11,74	11,00
	Sensitive capacity kW	12,20	12,09	11,97	11,74	9,39	8,80
	Input kW.	6,29	6,24	6,19	6,07	6,25	6,50
27°C D 19°C W	Total capacity kW	16,76	16,60	16,44	16,12	12,90	12,09
	Sensitive capacity kW	13,41	13,28	13,15	12,90	10,32	9,67
	Input kW.	6,44	6,40	6,35	6,23	6,41	6,66
32°C D 23°C W	Total capacity kW	18,78	18,60	18,42	18,05	14,44	13,54
	Sensitive capacity kW	15,02	14,88	14,73	14,44	11,55	10,83
	Input kW.	7,22	7,17	7,11	6,97	7,18	7,46

HEATING		OUTDOOR CONDITIONS						
Indoor Conditions		24°C D 18°C W	12°C D 11°C W	7°C D 6°C W	4°C D 3°C W	0°C D -1°C W	-5°C D -6°C W	-7°C D -8°C W
15°C	Capacity kW	22,54	22,29	19,52	16,01	13,66	10,74	9,95
	Input kW.	6,64	6,56	5,75	5,32	5,19	4,57	4,45
18°C	Capacity kW	21,53	21,29	18,64	15,28	13,05	10,25	9,51
	Input kW.	6,34	6,27	5,49	5,08	4,96	4,37	4,25
20°C	Capacity kW	20,31	20,08	17,58	14,42	12,31	9,67	8,97
	Input kW.	5,99	5,92	5,19	4,80	4,68	4,13	4,02
22°C	Capacity kW	17,26	17,07	14,95	12,26	10,46	8,22	7,62
	Input kW.	5,52	5,46	4,78	4,43	4,32	3,81	3,71
27°C	Capacity kW	17,26	17,07	14,95	12,26	10,46	8,22	7,62
	Input kW.	5,58	5,51	4,83	4,47	4,36	3,84	3,74

6. Wiring Diagrams

MTB-18HWN1-Q1

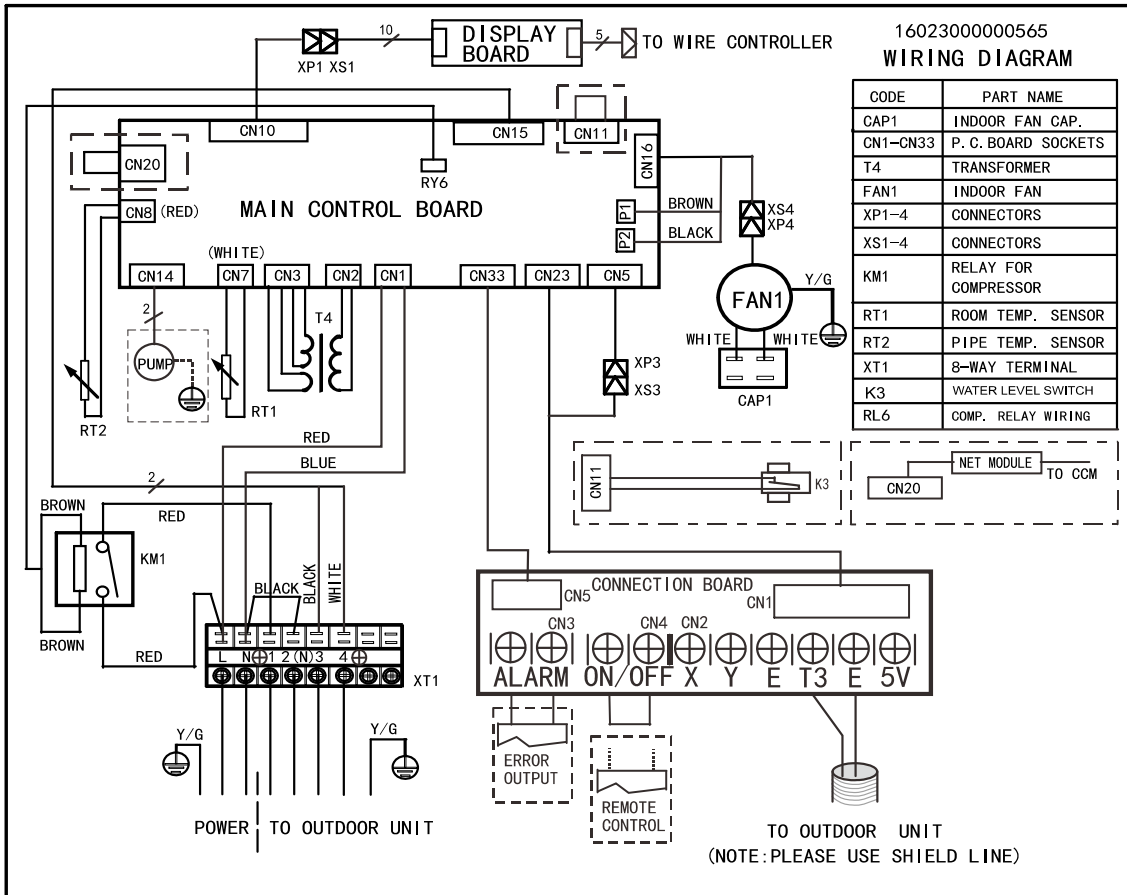

MTB-24HWN1-Q1

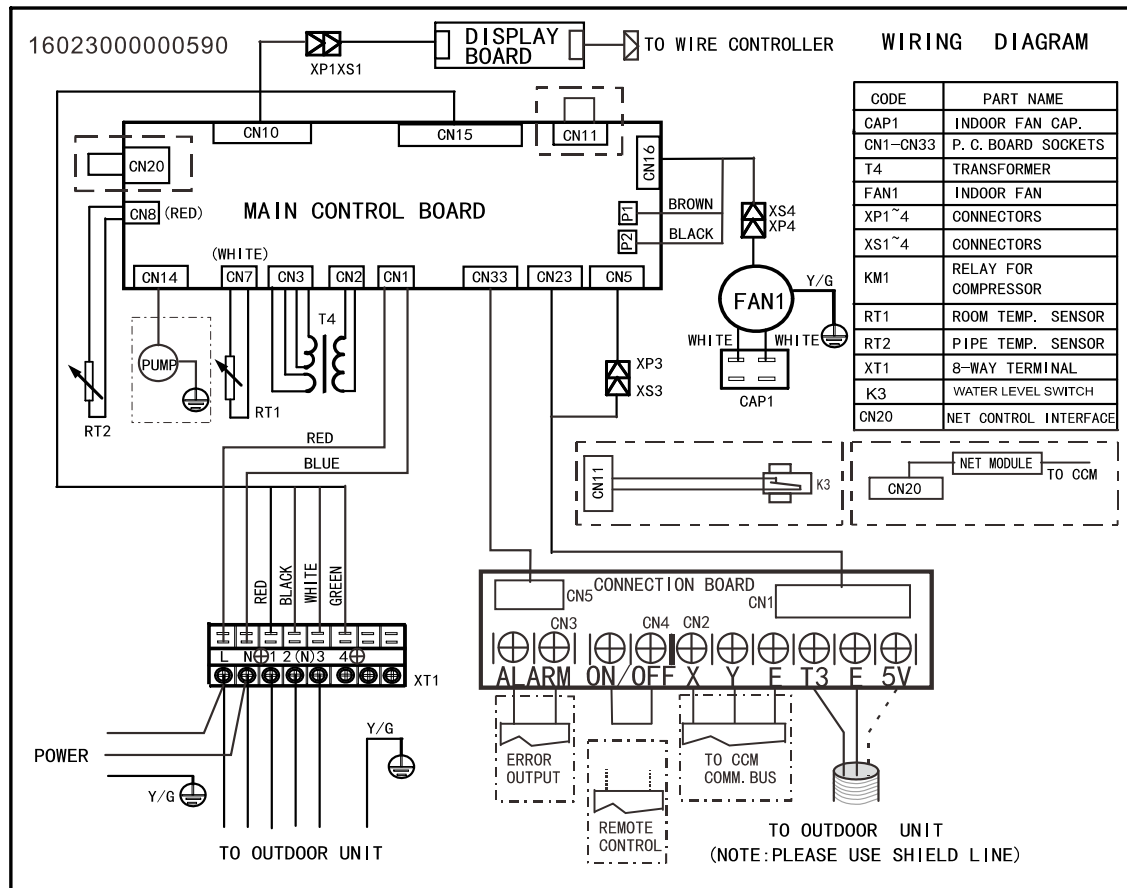

MTI-36HWN1-R1

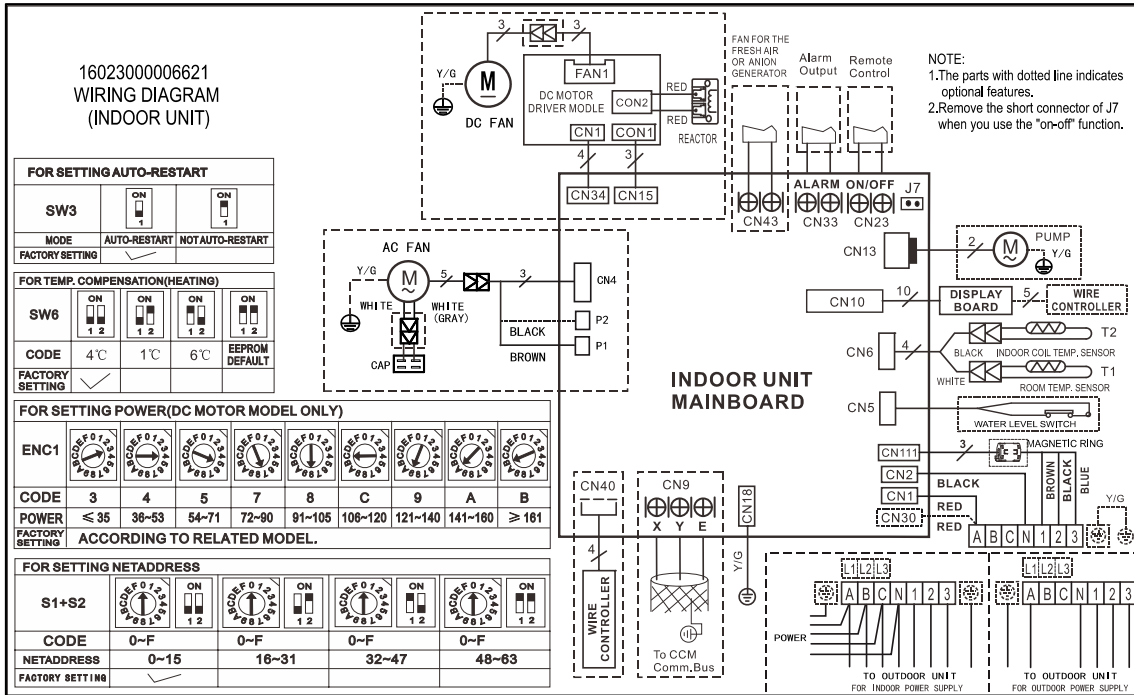

MTB-48HWN1-R, MTB-60HWN1-R

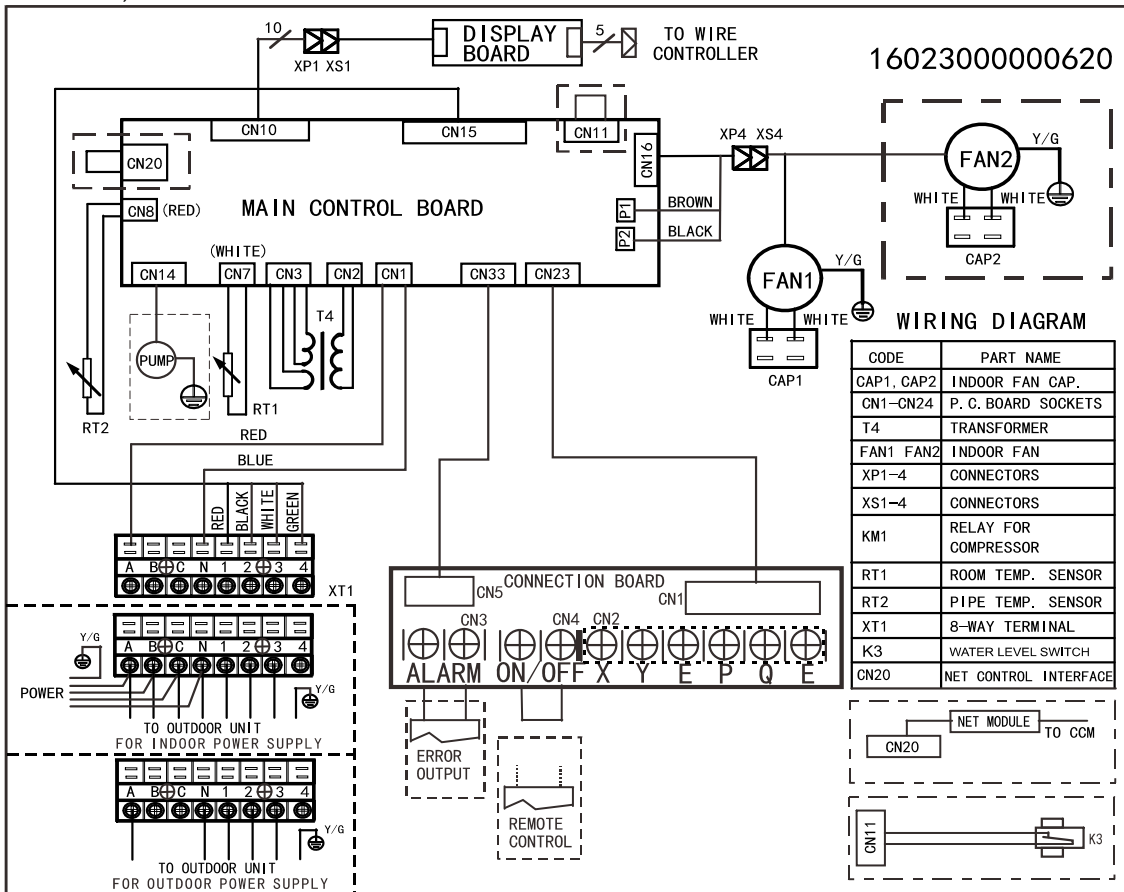

7. Static Pressure

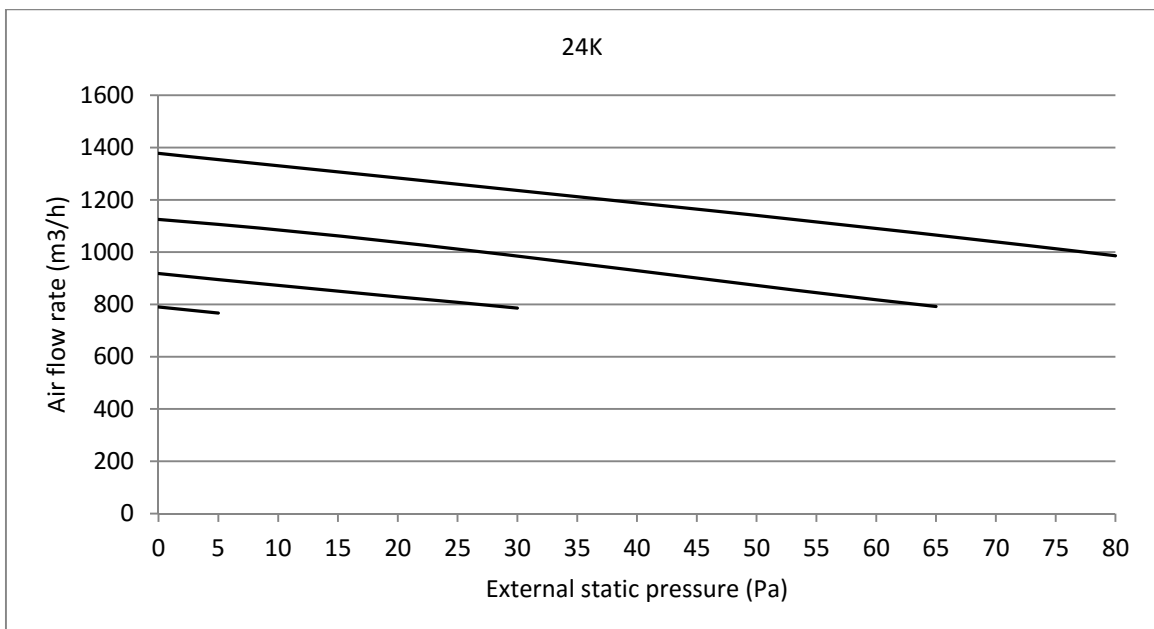
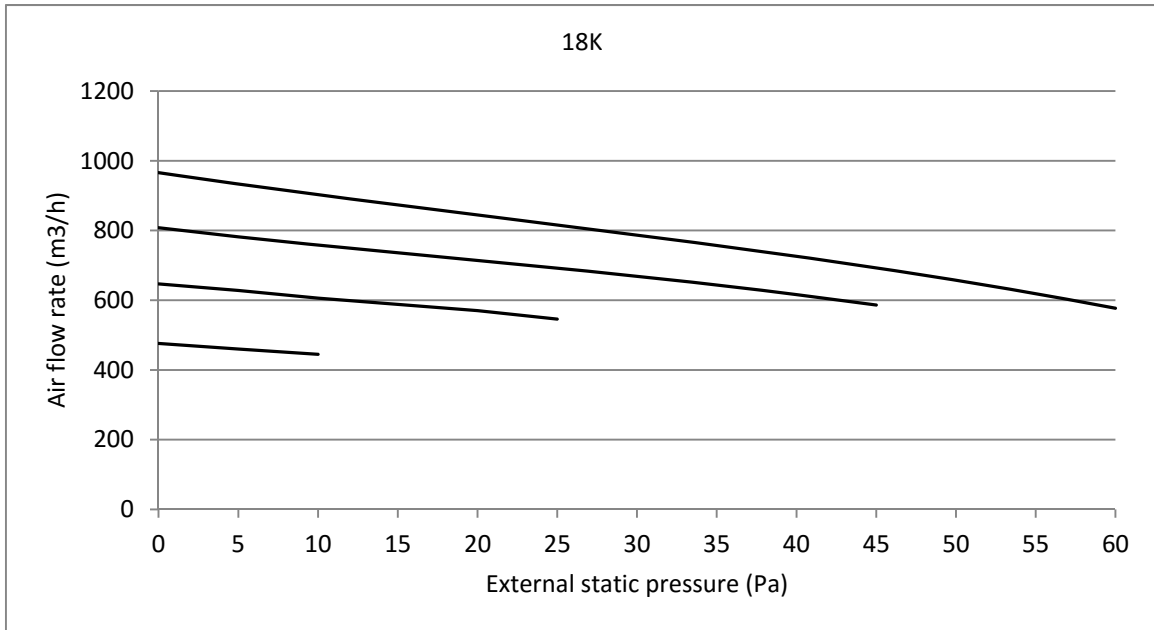

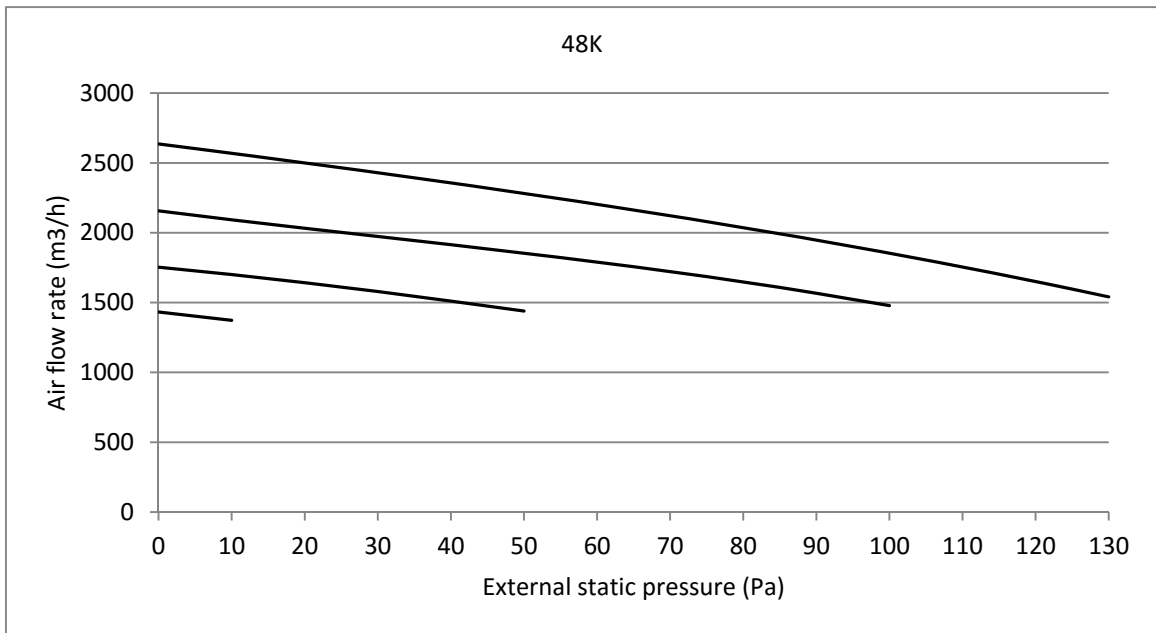
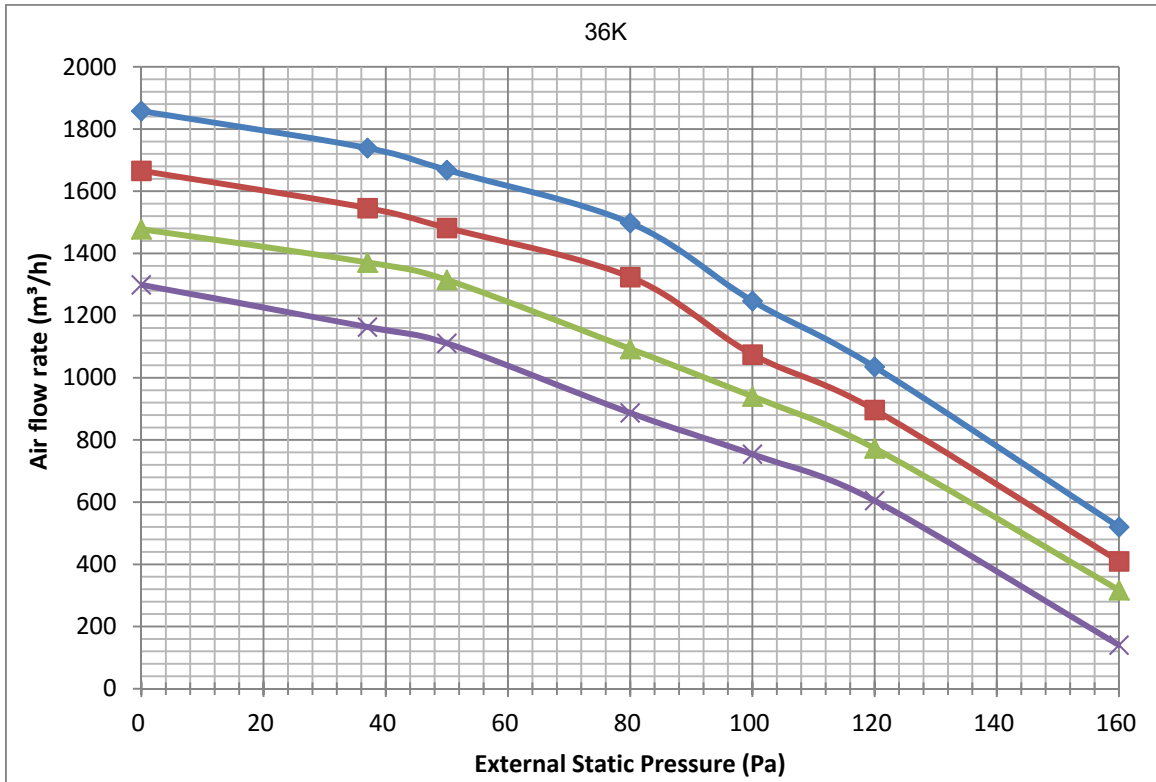

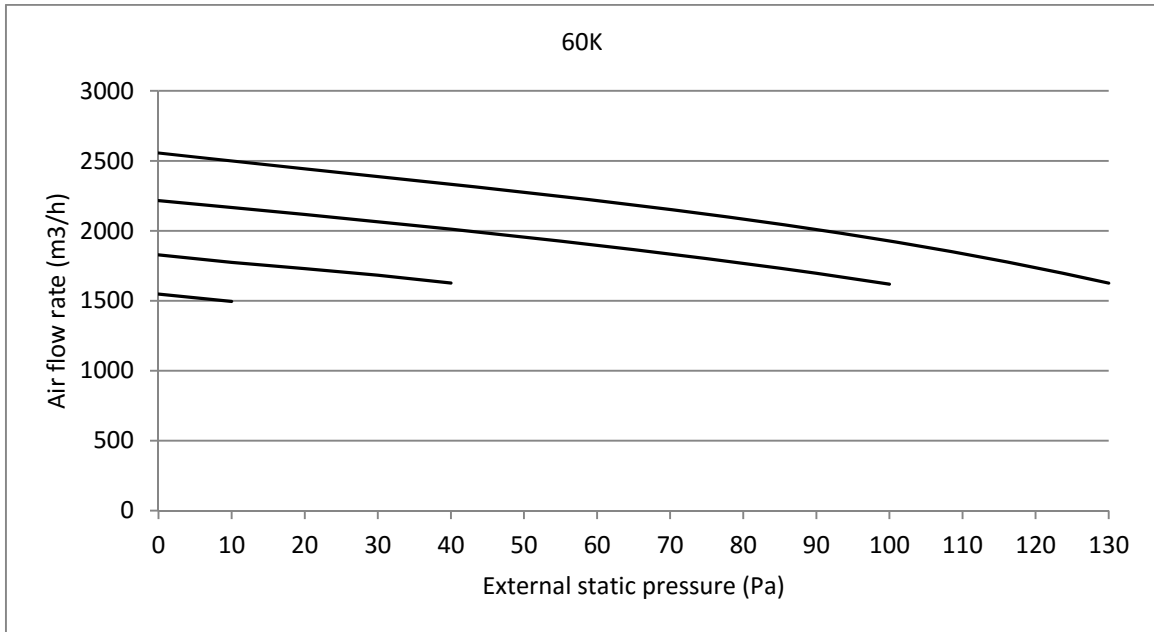

8. Electric Characteristics

Model	Indoor Units				Power Supply
	Hz	Voltage	Min.	Max.	MFA
MTB-18HWN1-Q1	50	220-240V	198V	254V	20
MTB-24HWN1-Q1	50	220-240V	198V	254V	25
MTI-36HWN1-R1	50	220-240V	198V	254V	/
MTB-48HWN1-R	50	380-415V	342V	436V	25
MTB-60HWN1-R	50	380-415V	342V	436V	25

Notes:

MFA: Max. Fuse Amps. (A)

9. Sound Levels

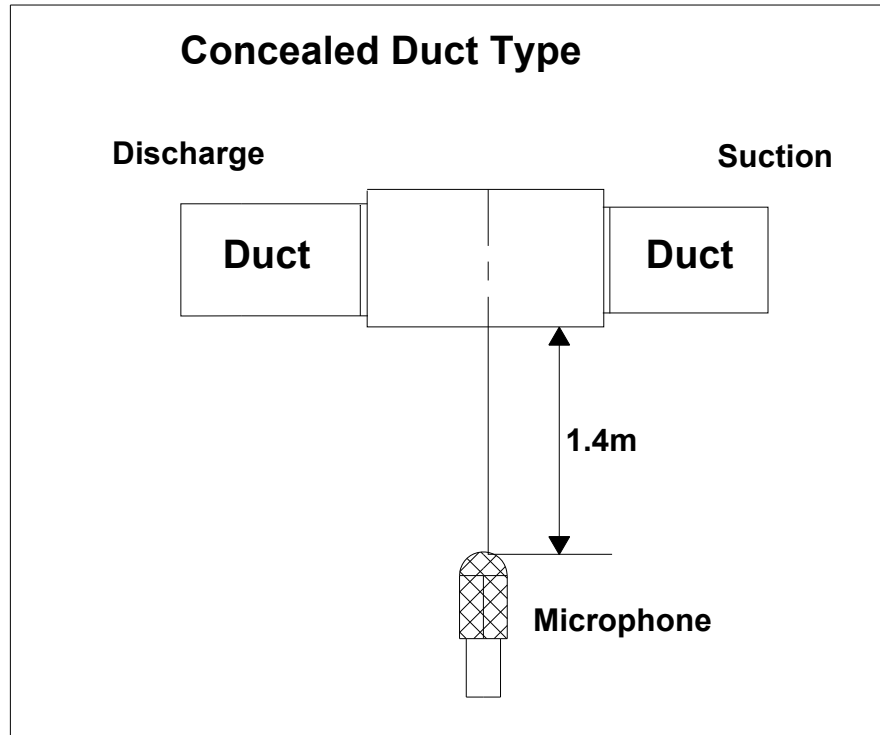

Model	Noise level dB(A)		
	H	M	L
MTB-18HWN1-Q	43	37	36
MTB-24HWN1-Q	45	40	38
MTI-36HWN1-R1	49	43	40
MTB-48HWN1-R	50	45	40
MTB-60HWN1-R	47	40	38

10. The Specification of Power

Model (KBtu/h)		18	24	36	48~60
Power	Phase	1-phase	1-phase	3-phase	3-phase
	Frequency and Voltage	220-240V, 50Hz		380-415V, 50Hz	380-415V, 50Hz
Circuit Breaker/ Fuse (A)		25/20	32/25	25/20	32/25
Indoor Unit Power Wiring (mm ²)		3×2.5	3×2.5	3×1.5	5×2.5
Indoor/Outdoor Wiring (mm ²)	Connecting				
	Ground Wiring	2.5	2.5	2.5	2.5
	Outdoor Unit Power Wiring	3×2.5	3×2.5	5×2.5	5×2.5
	Strong Electric Signal	2×1.0	3×1.0	3×1.0	3×1.0
	Weak Electric Signal	(2×0.75/ 2×0.5)	(2×0.2)	—————	—————

11. Field Wiring

MTB-18HWN1-Q1

Air Condition Link-Circuit

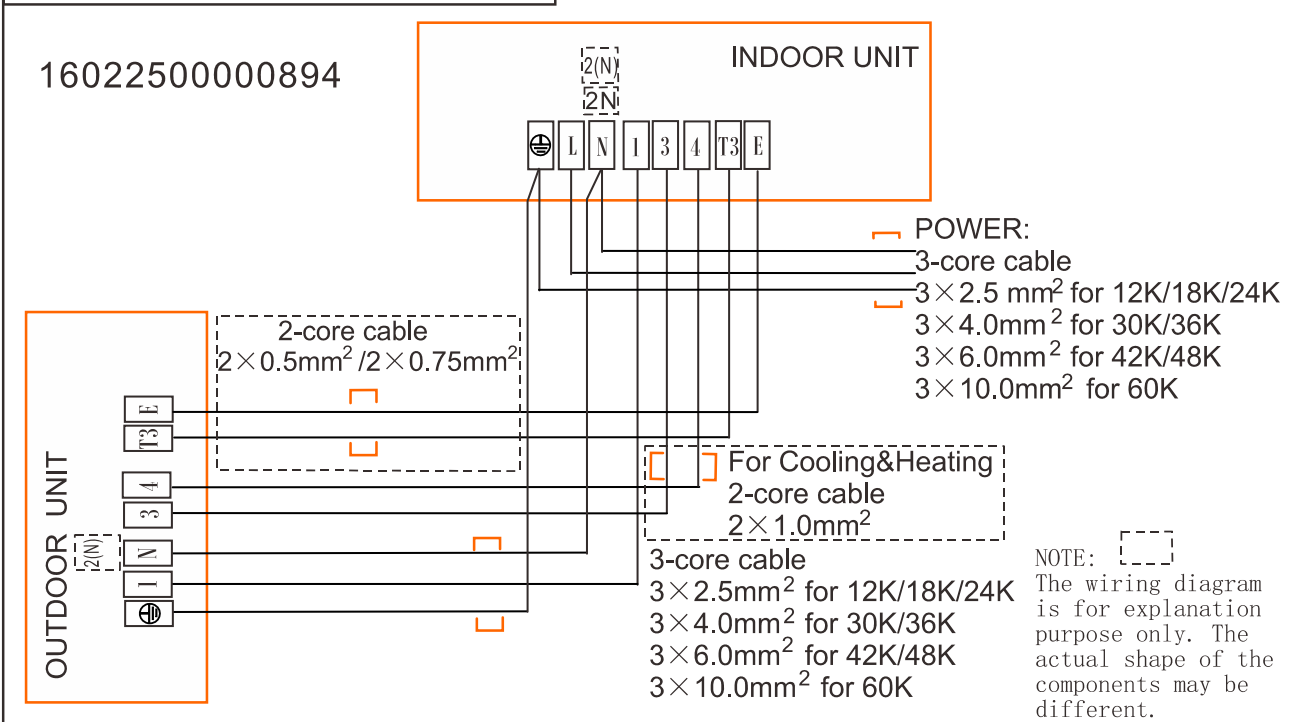

MTB-24HWN1-Q1

Air Condition Link-Circuit

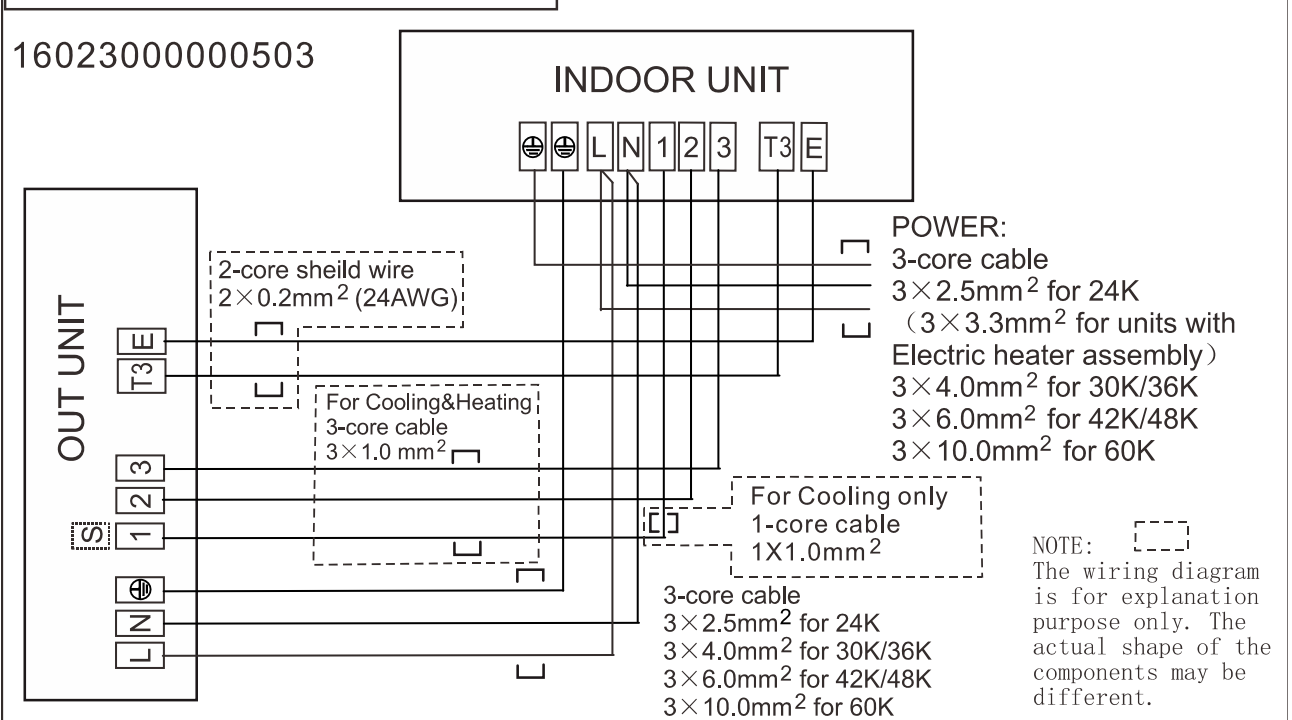

MTI-36HWN1-R

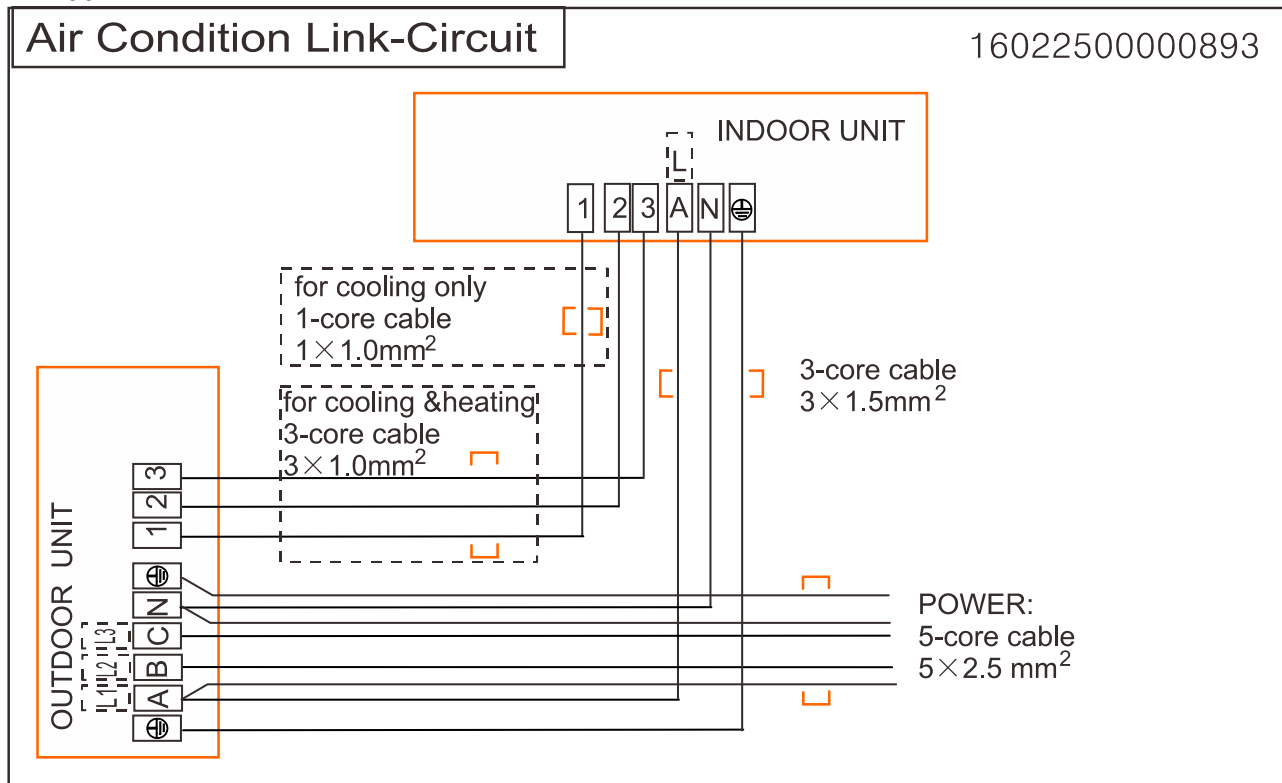

MTB-48HWN1-R, MTB-60HWN1-R

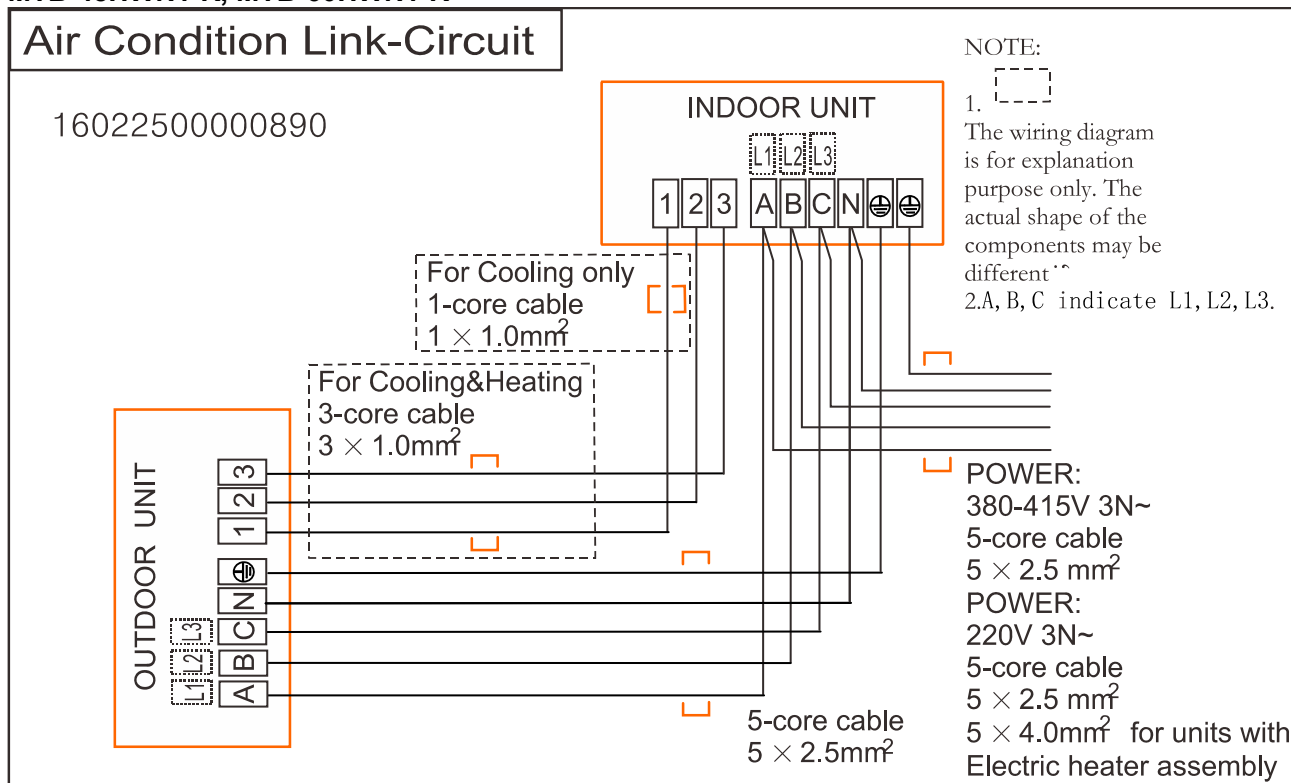

HSP Duct Type

1. Features	66
2. Specification.....	68
3. Dimensions.....	70
4. Service Space.....	71
5. Capacity tables.....	72
6. Wiring Diagrams	76
7. Static Pressure.....	80
8. Electric Characteristics	81
9. Sound Levels.....	82
10. The Specification of Power	83
11. Field Wiring.....	84

1. Features

1.1 High static pressure design

- Max static pressure of indoor unit is 160Pa.
- The longest distance of air supply is 14m, the max height of air supply is 6.5m.
- Specially recommended for spacious and large rooms like large stores and factories.

High static pressure design enables long duct.

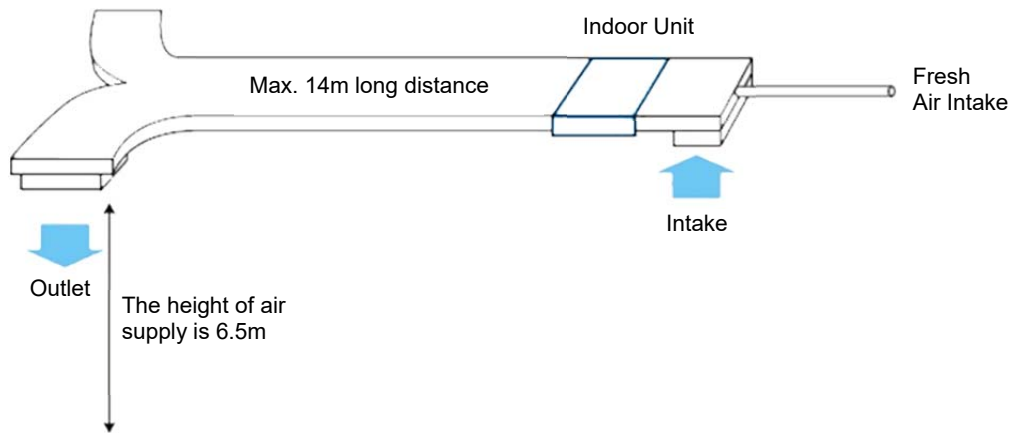

1.2 Easy maintenance

- The unit can be opened from top or bottom.

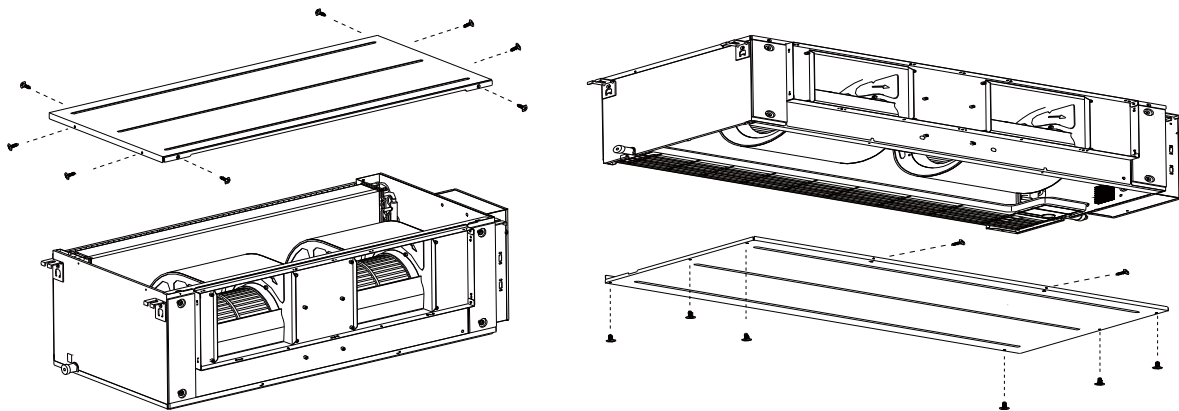

- The air outlet flange is isolated from either top panel or base panel, which makes the maintenance much easier when connecting duct.

1.3 Flexible Installation

- Different solutions for any shape room by using kinds of air distribution ducts.

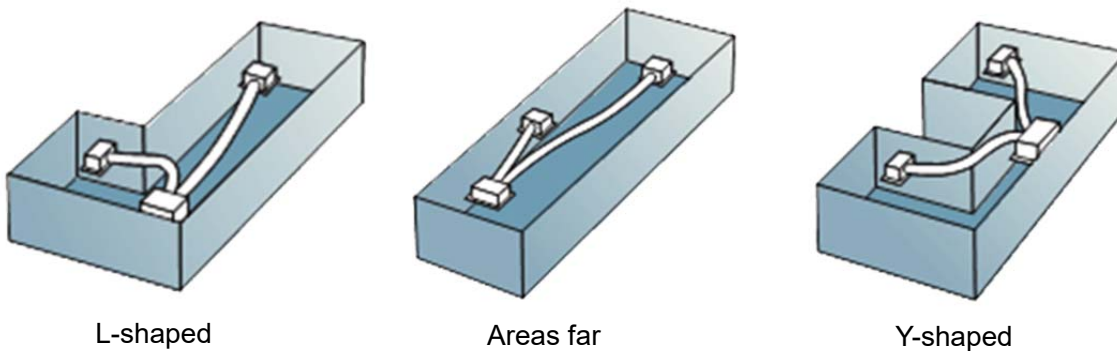

L-shaped

Areas far

Y-shaped

1.4 Easy cleaning filter

- The filter can be easily removed or installed from the rear side for ease of cleaning.

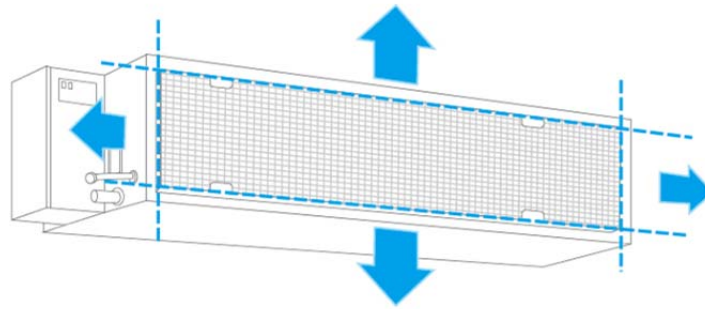

2. Specification

Indoor Model		MHG-24HWN1-Q1		
Outdoor Model		MOCA30U-24HN1-Q		
Power supply		V- Ph-Hz	220-240-1-50	
Cooling	Capacity	Btu/h	24000	
		kW	7.03	
	Input	W	2710	
	Current	A	13,01	
EER		W/W	2,60	
Heating	Capacity	Btu/h	26000	
		kW	7.62	
	Input	W	2270	
	Current	A	10,89	
COP		W/W	3,36	
Indoor fan motor	Model		YKSS-115-4-20	
	Qty		1	
	Input		W	228/180/155
	Capacitor		uF/ V	6.5UF/450V
	Speed (Hi/Mid/Lo)		r/min	1140/900/815
Indoor coil	Number of rows		3	
	Tube pitch(a)×row pitch(b)		mm	21x13.37
	Fin spacing		mm	1,4
	Fin type		Hydrophilic aluminium	
	Tube outside diameter .and type		mm	Φ7, innergroove tube
	Coil length×height×width		mm	776x252x40.11
Number of circuits		6		
Indoor air flow (Hi/Med/Lo)		m ³ /h	1615/1155/989	
ESP	Rated		Pa	25
	Range		Pa	0-120
Indoor noise level (Hi/Med/Lo)		dB(A)		48/42/38
Throttle type				/
Indoor unit	Dimension (W×D×H)		mm	900x525x270
	Packing (W×D×H)		mm	1130X555X340
	Net/Gross weight		kg	25/29.5
Design pressure		MPa	4.2/1.5	
Drainage water pipe dia				ODΦ25
Refrigerant piping	Liquid side/ Gas side		mm	Φ9.52Φ15.9(3/8"/5/8")
Controller		standard	KJR-12B/DP(T)-E-2	
Operation temperature		°C	17~30	
Room temperature	Cooling		°C	17~32
	Heating		°C	0~30

Indoor Model			MHG-36HWN1-R1	MHG-48HWN1-R	MHG-60HWN1-R
Outdoor Model			MOD31U-36HN1-R	MOU-48HN1-R	MOUA-60HN1-R
Power supply		V,Hz,Ph	380~420,50,3	380~420,50,3	380~415,50,3
Cooling	Capacity	Btu/h	36000	49000	56000
	Input	W	3750	5128	6500
	Current	A	6.3	9	11,2
	EER	W/W	2,81	2,8	2,53
Heating	Capacity	Btu/h	36000	52000	62000
	Input	W	3300	4220	5300
	Current	A	5.6	7,40	9,20
	COP	W/W	3,20	3,61	3,43
Indoor fan motor	Model		YKSS-210-4-1	YSK250-4C	YSK250-4C
	Qty		1	1	1
	Input	W	420/340/300	480/420/360	588/480/420
	Capacitor	uF/ V	10UF/450V	10μF/450V	10μF/450V
	Speed (Hi/Mid/Lo)	r/min	1200/1090/980	750/705/655	860/750/705
Indoor coil	Number of rows		4.0	3	3
	Tube pitch(a)×row pitch(b)	mm	21x13.37	21x13.37	21x13.37
	Fin spacing	mm	1.3	1.3	1,3
	Fin type		Hydrophilic aluminium	Hydrophilic aluminium	Hydrophilic aluminium
	Tube outside diameter and type	mm	Φ7,innergroove tube	Φ7,innergroove tube	Φ7,innergroove tube
	Coil length×height×width	mm	990x252x53.48	1055x357x40.11	1055x357x40.11
	Number of circuits		6	8	8
Indoor air flow (Hi/Med/Lo)		m ³ /h	2059/1819/1667	2809/2554/2272	3150/2809/2554
ESP	Rated	Pa	37	50	50
	Range	Pa	0-160	0-200	0-200
Indoor noise level (Hi/Med/Lo)		dB(A)	54.6/51.6/49.6	51/49/46	52/50/48
Throttle type			/	/	/
Indoor unit	Dimension (W×D×H)	mm	1100×525×270	1200×625×380	1200×625×380
	Packing (W×D×H)	mm	1335×555×340	1485×675×450	1485×675×450
	Net/Gross weight	kg	33.7/39.3	46/52.3	45.9/52.2
Design pressure		MPa	4.2/1.5	4.2/1.5	4.2/1.5
Drainage water pipe dia			ODΦ25	ODΦ25	ODΦ25
Refrigerant piping	Liquid side/ Gas side	mm	Φ9.52/Φ19(3/8"/3/4")	Φ12.7/Φ19	Φ12.7/Φ19
Controller		standard	KJR-12B/DP(T)-E-2	KJR-12B/DP(T)-E-2	KJR-12B/DP(T)-E-2
Operation temperature		°C	17~30	17~30	17~30
Room temperature	Cooling	°C	17~32	17~32	17~32
	Heating	°C	0~30	0~30	0~30

3. Dimensions

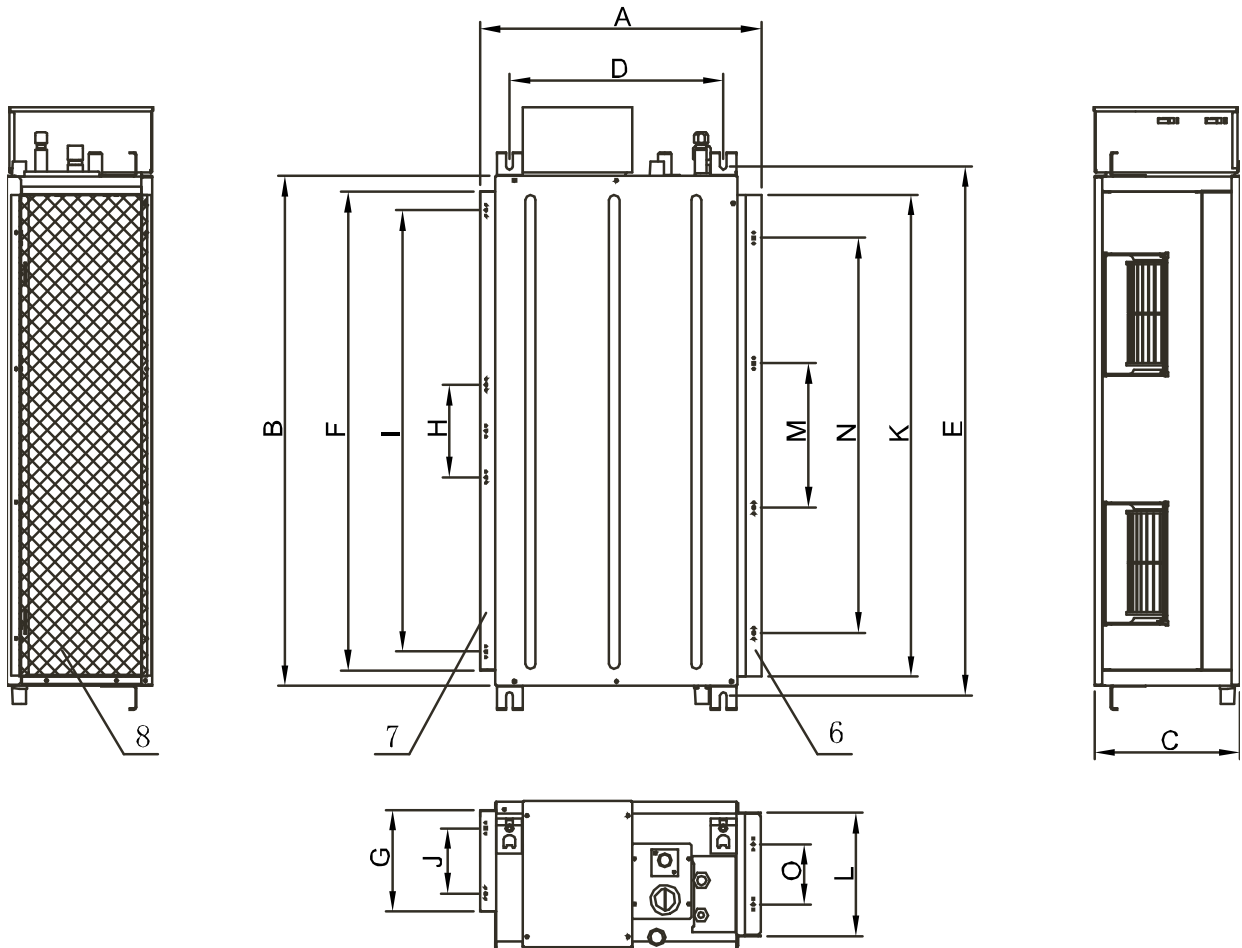

Capacity (KBtu)	Unit: mm														
	Outline dimension			Size of mounted lug		Air outlet opening size					Air inlet opening size				
	A	B	C	D	E	F	G	H	I	J	K	L	M	N	O
24	525	900	270	397	936	844	185	160	780	120	851	226	215	665	110
36	525	1110	270	397	1146	1054	185	220	960	120	1061	226	315	875	110
48/60	625	1200	380	495	1236	1000	253	270	900	170	1145	334	325	925	130

4. Service Space

Ensure enough space required for installation and maintenance.

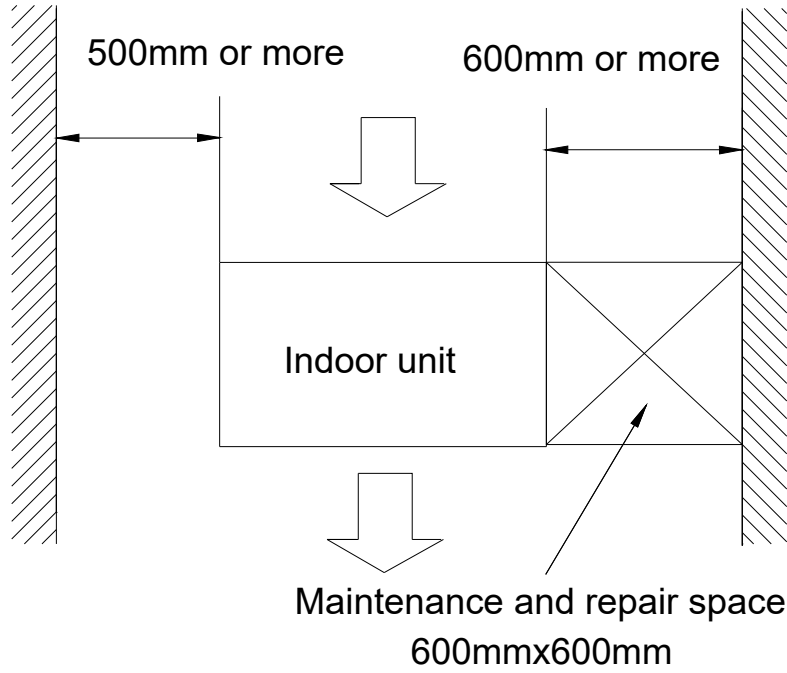

5. Capacity tables

5.1. MHG-24HWN1-Q1 / MOCA30U-24HN1-Q

COOLING		OUTDOOR TEMPERATURE DRY					
Indoor Conditions		21°C	25°C	30°C	35°C	40°C	45°C
21°C D 15°C W	Total capacity kW	6,51	6,44	6,38	6,26	5,01	4,69
	Sensitive capacity kW	5,21	5,16	5,11	5,01	4,00	3,75
	Input kW.	7,02	6,97	6,92	6,78	6,99	7,26
24°C D 17°C W	Total capacity kW	6,65	6,59	6,53	6,40	5,12	4,80
	Sensitive capacity kW	5,32	5,27	5,22	5,12	4,09	3,84
	Input kW.	2,74	2,72	2,70	2,64	2,72	2,83
27°C D 19°C W	Total capacity kW	7,31	7,24	7,17	7,03	5,62	5,27
	Sensitive capacity kW	5,85	5,79	5,74	5,62	4,50	4,22
	Input kW.	2,80	2,79	2,76	2,71	2,79	2,90
32°C D 23°C W	Total capacity kW	8,19	8,11	8,03	7,87	6,30	5,91
	Sensitive capacity kW	6,55	6,49	6,42	6,30	5,04	4,72
	Input kW.	3,14	3,12	3,10	3,04	3,13	3,25

HEATING		OUTDOOR CONDITIONS						
Indoor Conditions		24°C D 18°C W	12°C D 11°C W	7°C D 6°C W	4°C D 3°C W	0°C D -1°C W	-5°C D -6°C W	-7°C D -8°C W
15°C	Capacity kW	9,77	9,66	8,46	6,94	5,92	4,65	4,31
	Input kW.	2,91	2,87	2,52	2,33	2,27	2,00	1,95
18°C	Capacity kW	9,33	9,22	8,08	6,62	5,65	4,44	4,12
	Input kW.	2,77	2,74	2,40	2,22	2,17	1,91	1,86
20°C	Capacity kW	8,80	8,70	7,62	6,25	5,33	4,19	3,89
	Input kW.	2,62	2,59	2,27	2,10	2,05	1,81	1,76
22°C	Capacity kW	7,48	7,40	6,48	5,31	4,53	3,56	3,30
	Input kW.	2,42	2,39	2,09	1,94	1,89	1,67	1,62
27°C	Capacity kW	7,48	7,40	6,48	5,31	4,53	3,56	3,30
	Input kW.	2,44	2,41	2,11	1,96	1,91	1,68	1,64

5.2. MHG-36HWN1-R1 / MOD31U-36HN1-R

COOLING		OUTDOOR TEMPERATURE DRY					
Indoor Conditions		21°C	25°C	30°C	35°C	40°C	45°C
21°C D 15°C W	Total capacity kW	9,77	9,67	9,58	9,39	7,51	7,04
	Sensitive capacity kW	7,81	7,74	7,66	7,51	6,01	5,63
	Input kW.	10,54	10,47	10,38	10,18	10,49	10,89
24°C D 17°C W	Total capacity kW	9,98	9,89	9,79	9,60	7,68	7,20
	Sensitive capacity kW	7,99	7,91	7,83	7,68	6,14	5,76
	Input kW.	3,79	3,76	3,73	3,66	3,77	3,91
27°C D 19°C W	Total capacity kW	10,97	10,87	10,76	10,55	8,44	7,91
	Sensitive capacity kW	8,78	8,69	8,61	8,44	6,75	6,33
	Input kW.	3,88	3,86	3,83	3,75	3,86	4,01
32°C D 23°C W	Total capacity kW	12,29	12,17	12,05	11,82	9,45	8,86
	Sensitive capacity kW	9,83	9,74	9,64	9,45	7,56	7,09
	Input kW.	4,35	4,32	4,28	4,20	4,33	4,49

HEATING		OUTDOOR CONDITIONS						
Indoor Conditions		24°C D 18°C W	12°C D 11°C W	7°C D 6°C W	4°C D 3°C W	0°C D -1°C W	-5°C D -6°C W	-7°C D -8°C W
15°C	Capacity kW	13,53	13,37	11,71	9,60	8,20	6,44	5,97
	Input kW.	4,22	4,18	3,66	3,39	3,30	2,91	2,83
18°C	Capacity kW	12,92	12,77	11,18	9,17	7,83	6,15	5,70
	Input kW.	4,03	3,99	3,49	3,23	3,15	2,78	2,71
20°C	Capacity kW	12,19	12,05	10,55	8,65	7,39	5,80	5,38
	Input kW.	3,81	3,77	3,30	3,06	2,98	2,63	2,56
22°C	Capacity kW	10,36	10,24	8,97	7,35	6,28	4,93	4,57
	Input kW.	3,51	3,47	3,04	2,82	2,75	2,42	2,36
27°C	Capacity kW	10,36	10,24	8,97	7,35	6,28	4,93	4,57
	Input kW.	3,55	3,51	3,07	2,84	2,77	2,45	2,38

5.3. MHG-48HWN1-R / MOU-48HN1-R

COOLING		OUTDOOR TEMPERATURE DRY					
Indoor Conditions		21°C	25°C	30°C	35°C	40°C	45°C
21°C D 15°C W	Total capacity kW	13,29	13,16	13,04	12,78	10,23	9,59
	Sensitive capacity kW	10,63	10,53	10,43	10,23	8,18	7,67
	Input kW.	14,34	14,25	14,14	13,86	14,27	14,83
24°C D 17°C W	Total capacity kW	13,59	13,46	13,33	13,07	10,45	9,80
	Sensitive capacity kW	10,87	10,77	10,66	10,45	8,36	7,84
	Input kW.	5,18	5,14	5,10	5,00	5,15	5,35
27°C D 19°C W	Total capacity kW	14,94	14,79	14,65	14,36	11,49	10,77
	Sensitive capacity kW	11,95	11,83	11,72	11,49	9,19	8,62
	Input kW.	5,31	5,27	5,23	5,13	5,28	5,49
32°C D 23°C W	Total capacity kW	16,73	16,57	16,41	16,08	12,87	12,06
	Sensitive capacity kW	13,38	13,25	13,12	12,87	10,29	9,65
	Input kW.	5,94	5,90	5,86	5,74	5,92	6,15

HEATING		OUTDOOR CONDITIONS						
Indoor Conditions		24°C D 18°C W	12°C D 11°C W	7°C D 6°C W	4°C D 3°C W	0°C D -1°C W	-5°C D -6°C W	-7°C D -8°C W
15°C	Capacity kW	19,54	19,32	16,92	13,87	11,84	9,30	8,63
	Input kW.	5,40	5,34	4,68	4,33	4,22	3,72	3,62
18°C	Capacity kW	18,66	18,45	16,15	13,25	11,31	8,89	8,24
	Input kW.	5,16	5,10	4,46	4,13	4,03	3,55	3,46
20°C	Capacity kW	17,60	17,40	15,24	12,50	10,67	8,38	7,77
	Input kW.	4,87	4,82	4,22	3,91	3,81	3,36	3,27
22°C	Capacity kW	14,96	14,79	12,95	10,62	9,07	7,12	6,61
	Input kW.	4,49	4,44	3,89	3,60	3,51	3,10	3,02
27°C	Capacity kW	14,96	14,79	12,95	10,62	9,07	7,12	6,61
	Input kW.	4,54	4,49	3,93	3,64	3,55	3,13	3,04

5.4. MHG-60HWN1-R / MOUA-60HN1-R

COOLING		OUTDOOR TEMPERATURE DRY					
Indoor Conditions		21°C	25°C	30°C	35°C	40°C	45°C
21°C D 15°C W	Total capacity kW	15,19	15,05	14,90	14,61	11,69	10,96
	Sensitive capacity kW	12,15	12,04	11,92	11,69	9,35	8,76
	Input kW.	16,39	16,28	16,15	15,84	16,31	16,95
24°C D 17°C W	Total capacity kW	15,53	15,38	15,23	14,94	11,95	11,20
	Sensitive capacity kW	12,43	12,31	12,19	11,95	9,56	8,96
	Input kW.	6,56	6,52	6,47	6,34	6,53	6,78
27°C D 19°C W	Total capacity kW	17,07	16,91	16,74	16,41	13,13	12,31
	Sensitive capacity kW	13,66	13,52	13,39	13,13	10,50	9,85
	Input kW.	6,73	6,68	6,63	6,50	6,70	6,96
32°C D 23°C W	Total capacity kW	19,12	18,93	18,75	18,38	14,71	13,79
	Sensitive capacity kW	15,29	15,15	15,00	14,71	11,76	11,03
	Input kW.	7,53	7,48	7,43	7,28	7,50	7,79

HEATING		OUTDOOR CONDITIONS						
Indoor Conditions		24°C D 18°C W	12°C D 11°C W	7°C D 6°C W	4°C D 3°C W	0°C D -1°C W	-5°C D -6°C W	-7°C D -8°C W
15°C	Capacity kW	23,30	23,03	20,17	16,54	14,12	11,09	10,29
	Input kW.	6,78	6,71	5,87	5,44	5,30	4,67	4,55
18°C	Capacity kW	22,25	22,00	19,26	15,79	13,48	10,59	9,82
	Input kW.	6,48	6,40	5,61	5,19	5,06	4,46	4,35
20°C	Capacity kW	20,99	20,75	18,17	14,90	12,72	9,99	9,27
	Input kW.	6,12	6,05	5,30	4,91	4,79	4,22	4,11
22°C	Capacity kW	17,84	17,64	15,45	12,67	10,81	8,50	7,88
	Input kW.	5,64	5,58	4,89	4,52	4,41	3,89	3,79
27°C	Capacity kW	17,84	17,64	15,45	12,67	10,81	8,50	7,88
	Input kW.	5,70	5,63	4,93	4,57	4,46	3,93	3,82

6. Wiring Diagrams

MHG-24HWN1-Q1

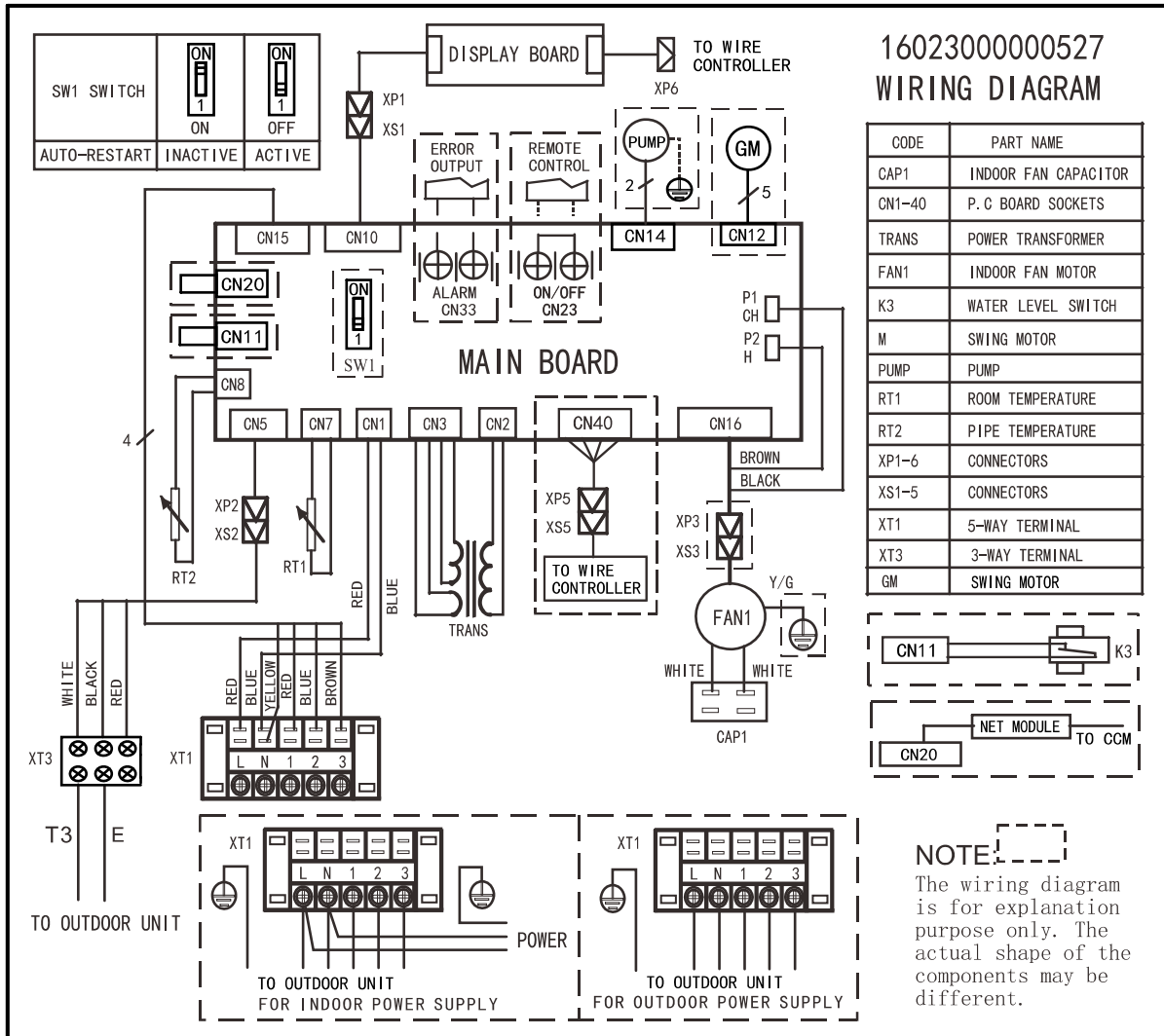

MHG-36HWN1-R1

16023000000623
WIRING DIAGRAM
(INDOOR UNIT)

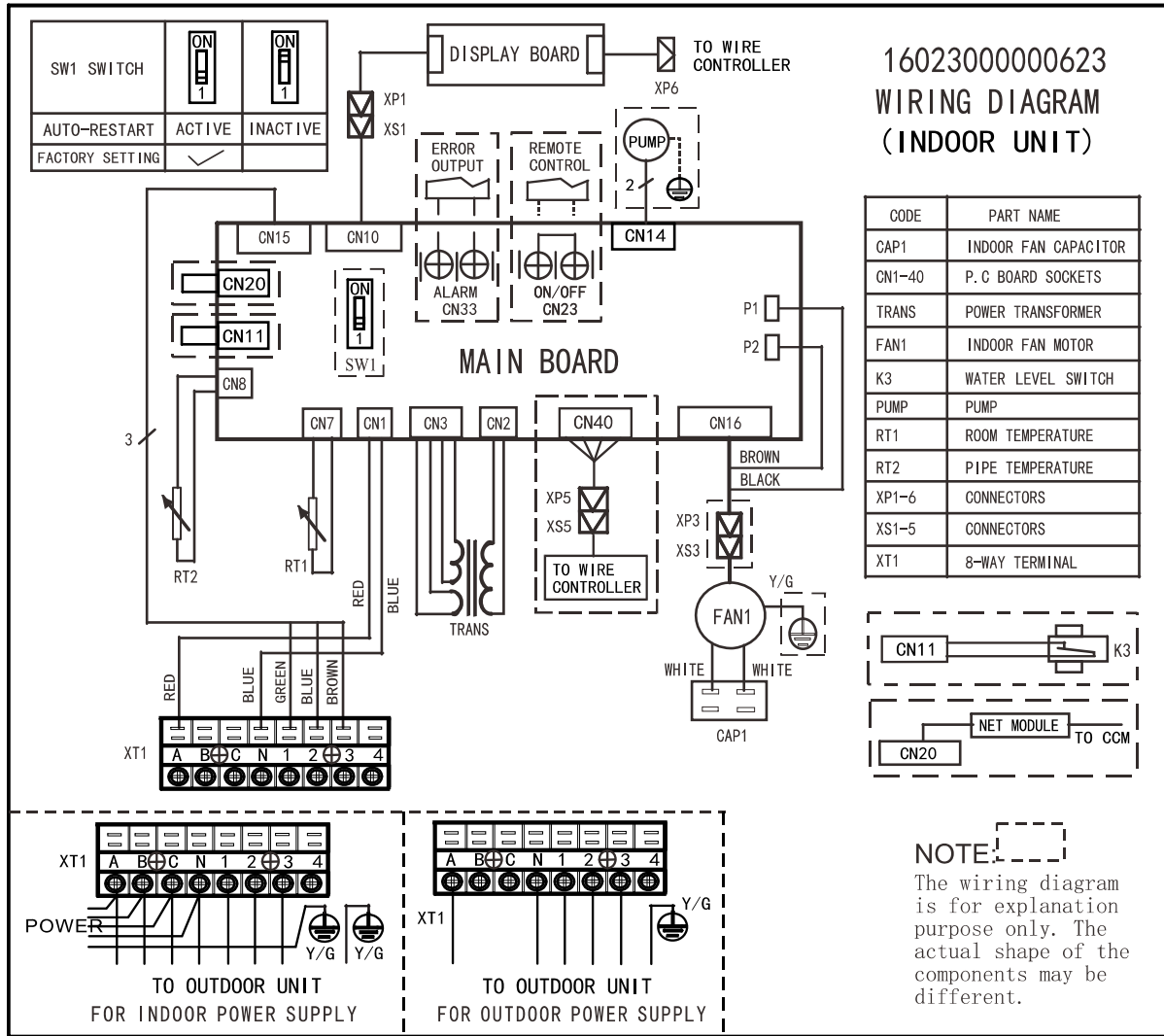

NOTE
The wiring diagram is for explanation purpose only. The actual shape of the components may be different.

MHG-48HWN1-R

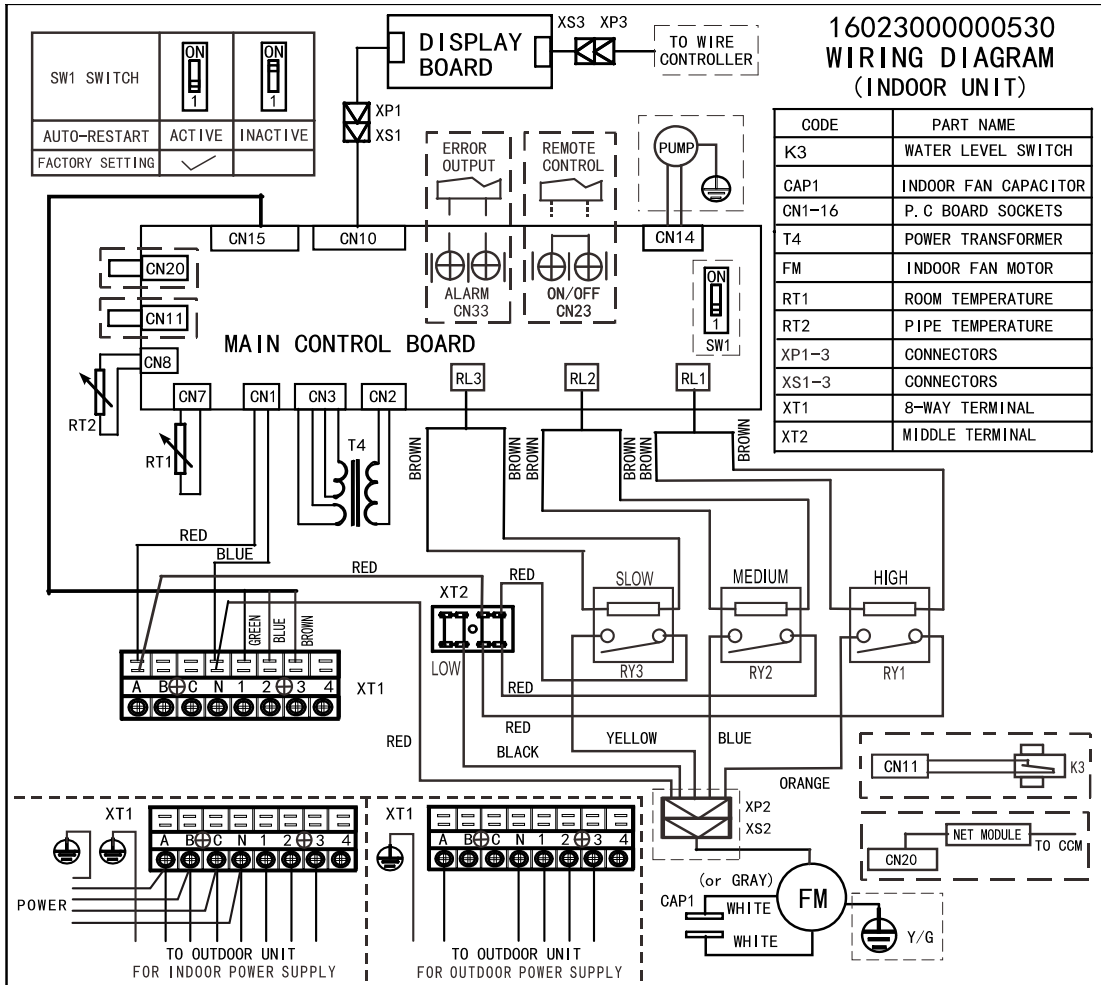

MHG-60HWN1-R

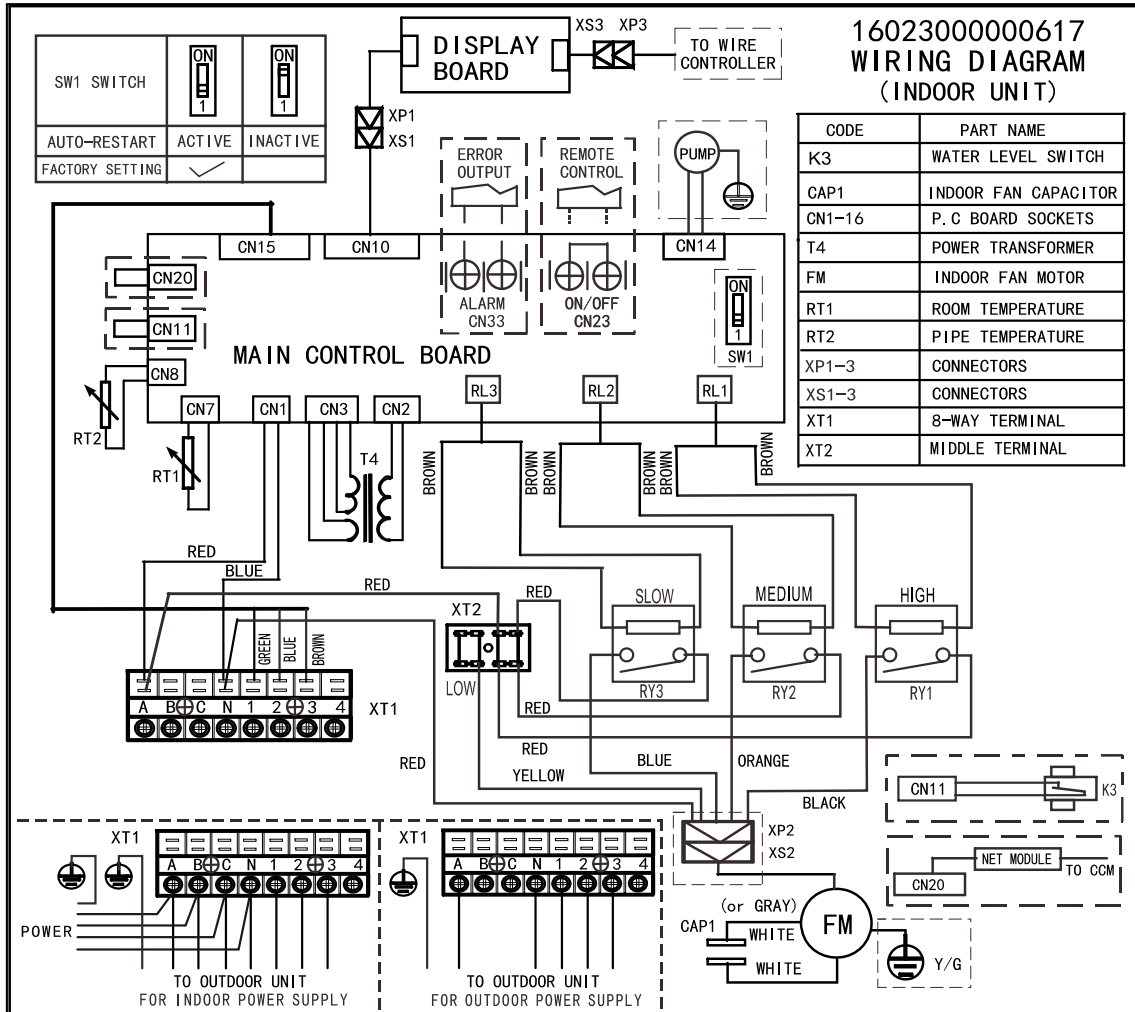

7. Static Pressure

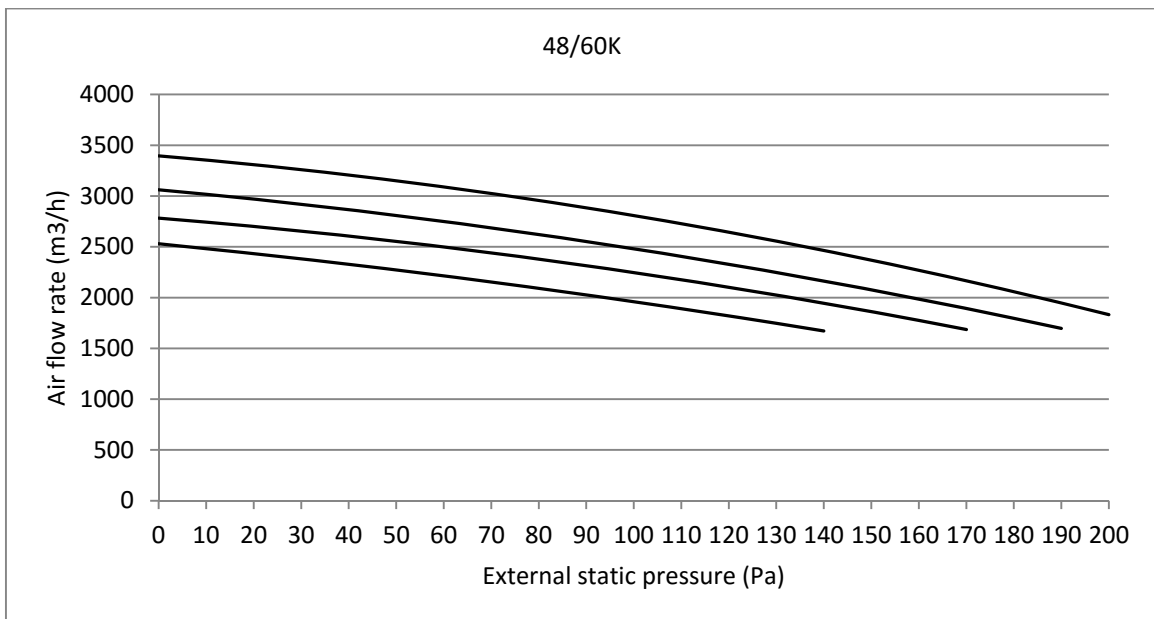
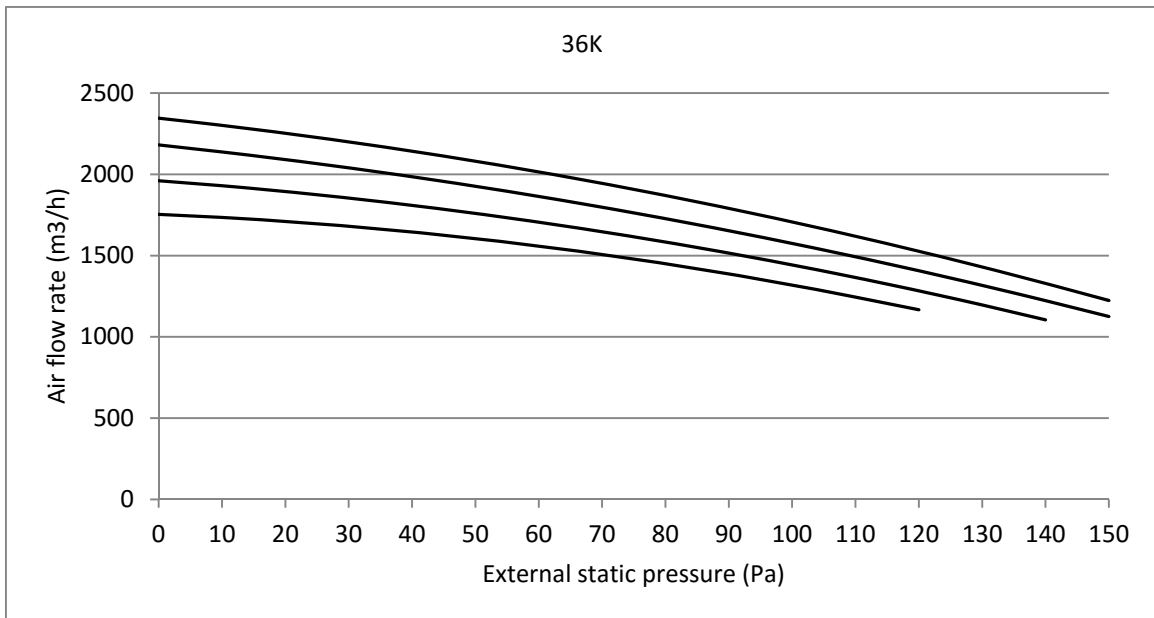
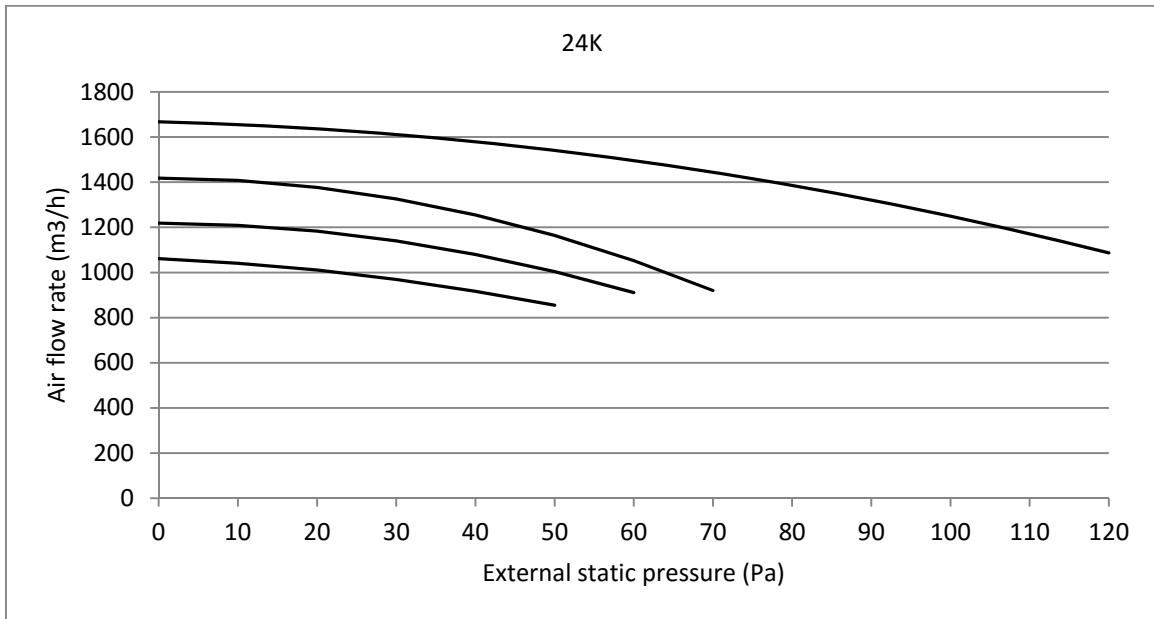

8. Electric Characteristics

Model	Indoor Unit				Power Supply
	Hz	Voltage	Min.	Max.	MFA
MHG-24HWN1-Q1	50	220-240V	198V	254V	25
MHG-36HWN1-R1	50	220-240V	198V	254V	/
MHG-48HWN1-R	50	380-415V	342V	436V	25
MHG-60HWN1-R	50	380-415V	342V	436V	25

Notes:

MFA: Max. Fuse Amps. (A)

9. Sound Levels

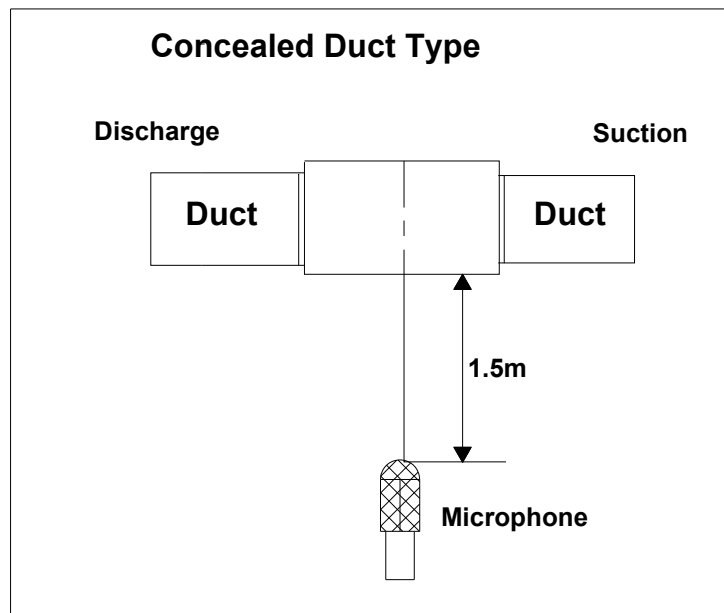

Model	Noise level dB(A)		
	H	M	L
MHG-24HWN1-Q1	48	42	38
MHG-36HWN1-R1	55	52	50
MHG-48HWN1-R	51	49	46
MHG-60HWN1-R	52	50	48

10. The Specification of Power

Model (KBtu/h)		24	36	48~60
Power	Phase	1-phase	3-phase	3-phase
	Frequency and Voltage	220-240V, 50Hz	380-415V, 50Hz	380-415V, 50Hz
Circuit Breaker/ Fuse (A)		32/25	25/20	32/25
Indoor Unit Power Wiring (mm ²)		3×2.5	3×1.5	5×2.5
Indoor/Outdoor Connecting Wiring (mm ²)	Ground Wiring	2.5	2.5	2.5
	Outdoor Unit Power Wiring	3×2.5	5×2.5	5×2.5
	Strong Electric Signal	3×1.0	3×1.0	3×1.0
	Weak Electric Signal	(2×0.2)	—————	—————

11. Field Wiring

MHG-24HWN1-Q1

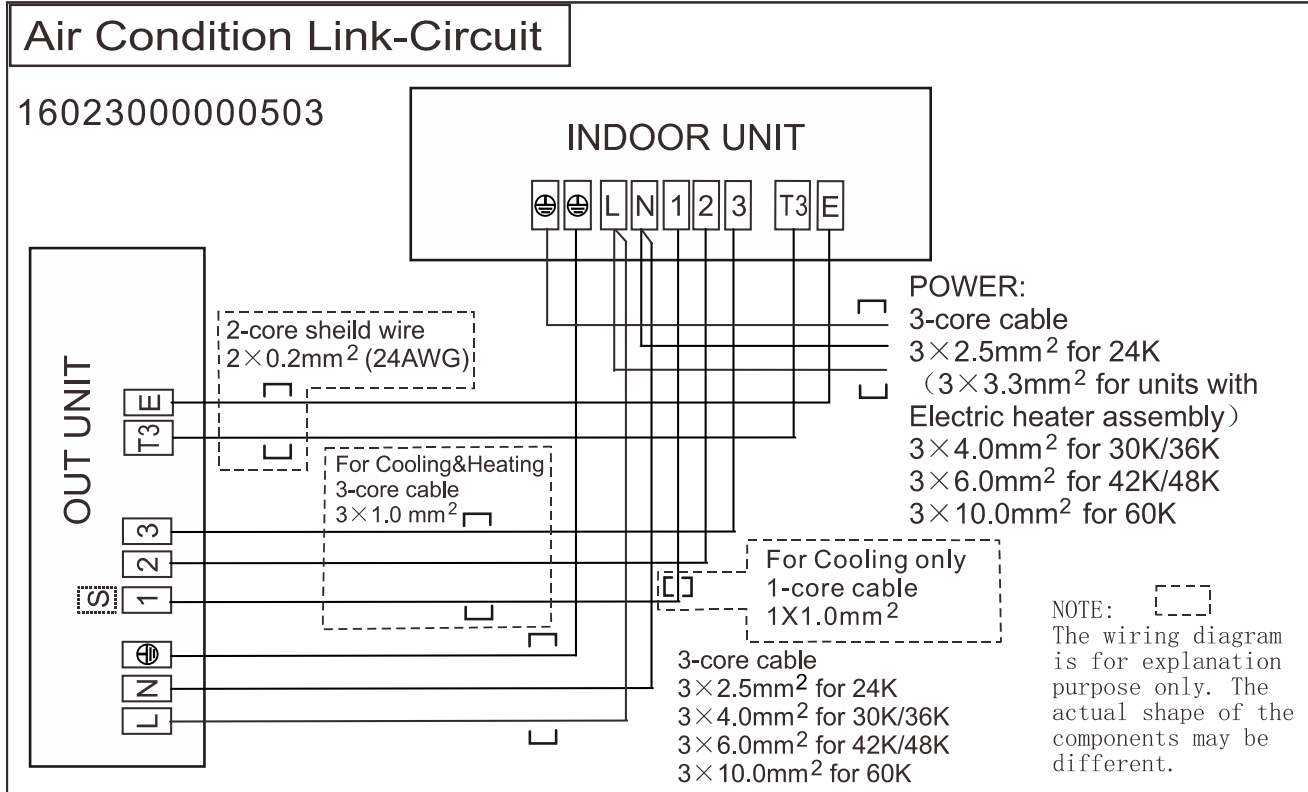

MHG-36HWN1-R1

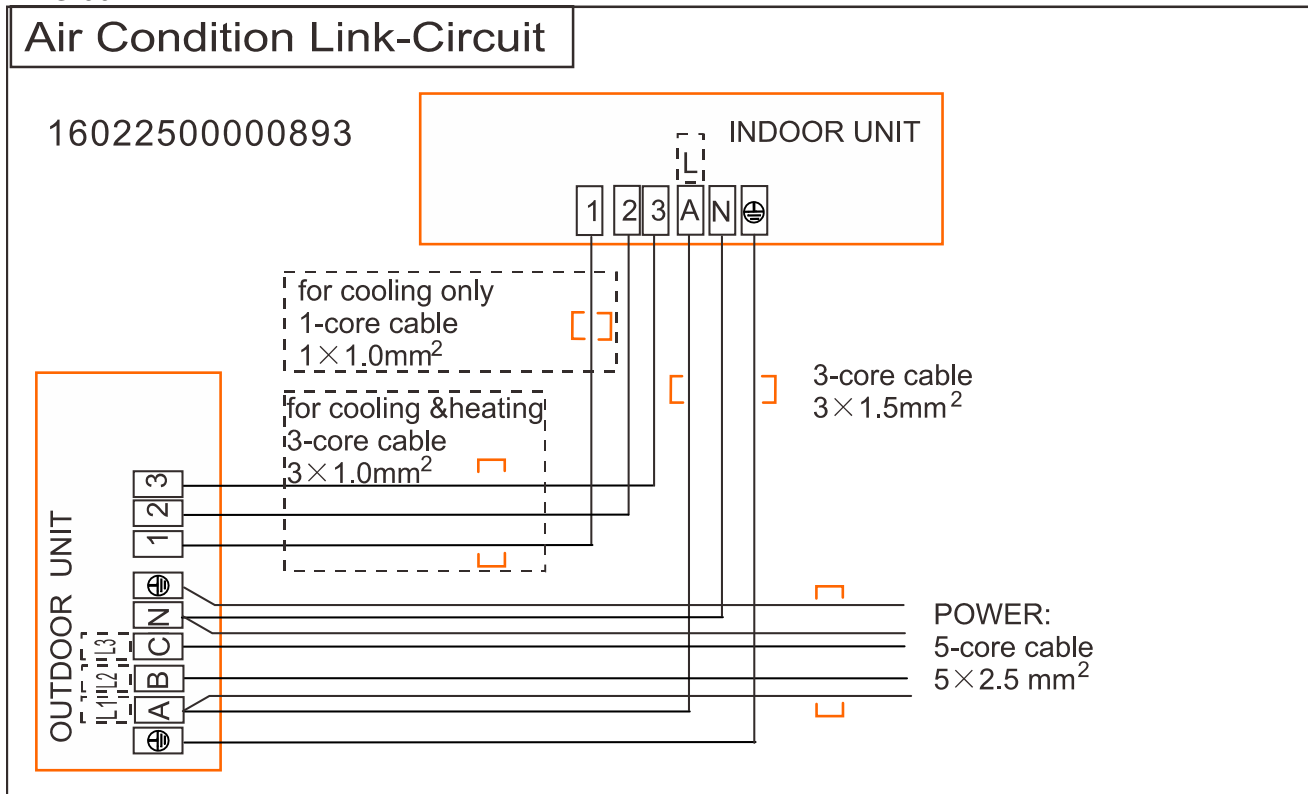

MHG-48HWN1-R, MHG-60HWN1-R

Air Condition Link-Circuit

16022500000890

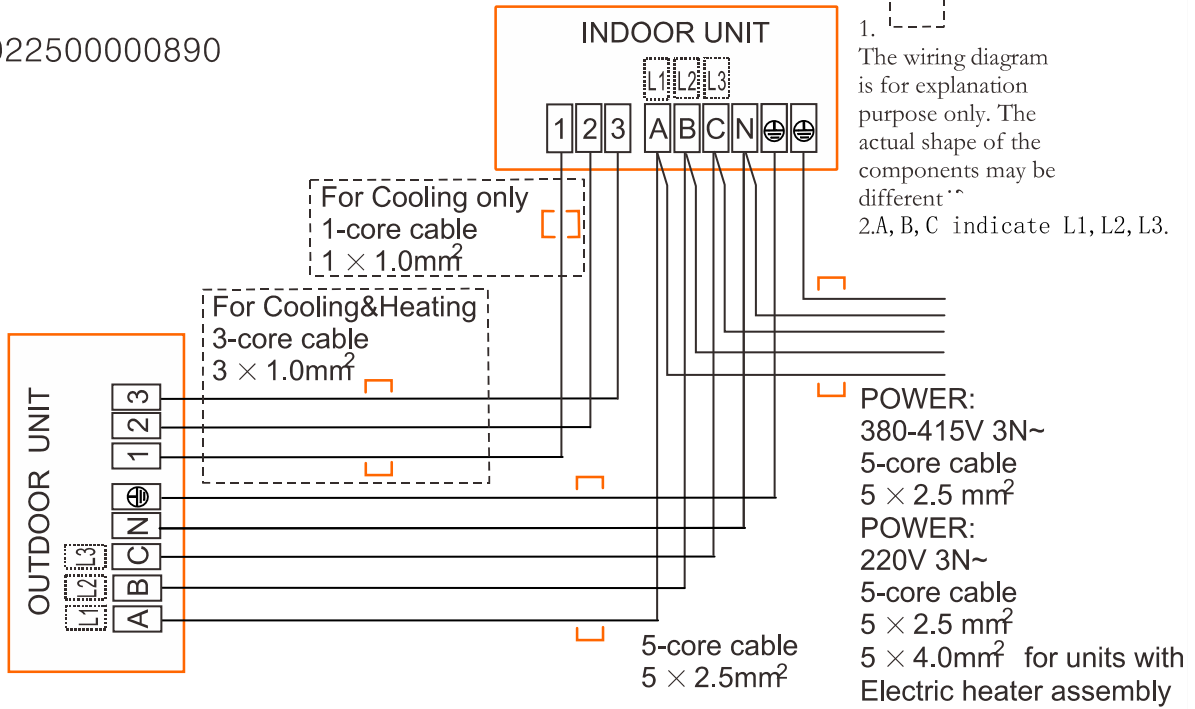

Ceiling & Floor Type

1. Features.....	87
2. Specification.....	88
3. Dimensions.....	90
4. Service Space.....	91
5. Capacity tables.....	92
6. Wiring Diagram	98
7. Electric Characteristics	100
8. Sound Levels.....	101
9. The Specification of Power	102
10. Field Wiring	103

1. Features

1.1. New design, more modern and elegant appearance.



1.2. Convenient installation

- The ceiling type can be easily installed into a corner of the ceiling even if the ceiling is very narrow
- It is especially useful when installation of an air conditioner in the center of the ceiling is impossible due to a structure such as one lighting.

1.3. Two direction auto swing (vertical & horizontal) and wide angle air flow,

- Air flow directional control minimizes the air resistance and produces wilder air flow to vertical direction.
- The range of horizontal air discharge is widened which secures wider air flow distribution to provide more comfortable air circulation no matter where the unit is set up

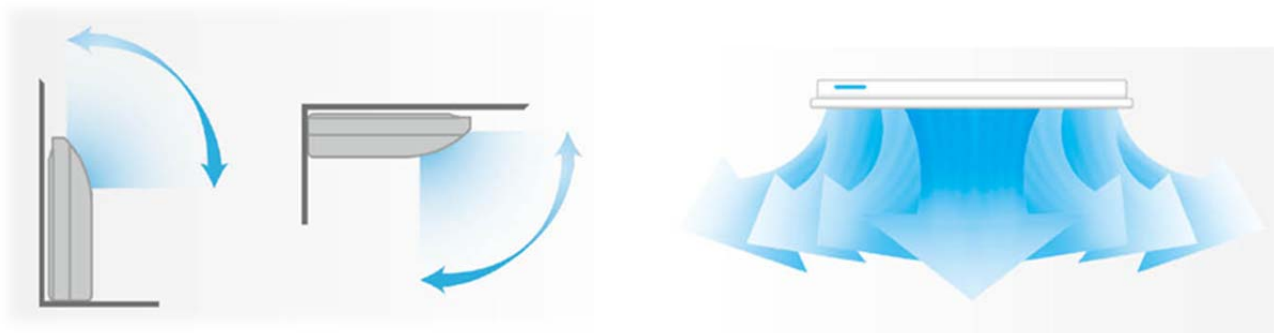

1.4. Three level fan speed, more humanism design, meets different air-supply requirement.

1.5. New foam drain pan with plastic-spraying inner surface



1.6. Easy operation.

2. Specification

Indoor Model			MUE-12HRN1-Q1	MUE-18HRN1-Q1	MUE-24HRN1-Q1
Outdoor Model			MOBA30U-12HN1-Q	MOBA30U-18HN1-Q	MOCA30U-24HN1-Q
Power supply		V-ph-Hz	220~240-1-50	220~240-1-50	220~240-1-50
Cooling	Capacity	Btu/h	12500	18500	24000
		kW	3.66	5.42	7.03
	Input	W	1350	2110	2630
	Current	A	6	9.36	12.62
	EER	W/W	2,71	2,57	2,67
Heating	Capacity	Btu/h	13000	19000	26000
		kW	3.81	5.57	7.62
	Input	W	1280	1730	2450
	Current	A	5,69	7,67	11,76
	COP	W/W	2,98	3,22	3,11
Indoor fan motor	Model		YKTS-25-6-3	YKSS-55-4-27-1	YKSS-55-4-27-1
	Qty		1	1	1
	Input	W	33.4/31.1+29.5	125/105/85	125/105/85
	Capacitor	uF	1.2UF/450V	2UF/450V	2.5UF/450V
	Speed(Hi/Med/Lo)	r/min	756/666/592	1310/1190/1040	1310/1190/1040
Indoor coil	Number of rows		2	2	2
	Tube pitch(a)x row pitch(b)	mm	21x13.37	21x13.37	21x13.37
	Fin spacing	mm	1,3	1,3	1,3
	Fin type		Hydrophilic aluminium	Hydrophilic aluminium	Hydrophilic aluminium
	Tube outside dia.and type	mm	Φ7,innergroove tube	Φ7,innergroove tube	Φ7,innergroove tube
	Coil length x height x width	mm	795x294x26.74	795x294x26.74	795x294x26.74
	Number of circuits		3	6	6
Indoor air flow(Hi/Med/Lo)		m ³ /h	620/500/400	1150/950/800	1250/1050/900
Indoor noise level (sound pressure)(Hi/Med/Lo)		dB(A)	37/33/30	53/48/43	54/49/44
Throttle type			/	/	/
Indoor unit	Dimension (WxDxH)	mm	1068x675x235	1068x675x235	1068x675x235
	Packing (WxDxH)	mm	1145x755x313	1145x755x313	1145x755x313
	Net/Gross weight	kg	23.6/28.8	24/29	24.6/29.8
Design pressure		MPa	4.2/1.5	4.2/1.5	4.2/1.5
Drainage water pipe diameter		mm	ODΦ25	ODΦ25	ODΦ25
Refrigerant piping	Liquid side/Gas side	mm(inch)	Φ6.35/Φ12.7(1/4"/1/2")	Φ6.35/Φ12.7(1/4"/1/2")	Φ9.52Φ15.9(3/8"/5/8")
Controller			RG36C/BG(C)E	RG36C/BG(C)E	RG36C/BG(C)E
Operation temperature		°C	17~30	17~30	17~30
Room temperature	Cooling	°C	17~32	17~32	17~32
	Heating	°C	0~30	0~30	0~30

Indoor Model			MUE-36HRN1-R1	MUE-48HRN1-R	MUE-60HRN1-R
Outdoor Model			MOD31U-36HN1-R	MOU-48HN1-R	MOUA-60HN1-R
Power supply		V-ph-Hz	380~415-3-50	380~415-3-50	380~415-3-50
Cooling	Capacity	Btu/h	36000	48000	55000
	Input	W	3600	5060	6400
	Current	A	6	8.4	10.5
	EER	W/W	2,93	2,78	2.52
Heating	Capacity	Btu/h	36000	52000	60000
	Input	W	3650	5063	5800
	Current	A	6.1	8.6	9.6
	COP	W/W	2,89	3,01	3.03
Indoor fan motor	Model		YKSS-125-4-5	YSK125-4C	YSK85-4C
	Qty		1	1	2
	Input	W	148/131/122	148/131/122	120/110/105
	Capacitor	uF	4.5	4.5uF/450V-P0	2.5uF/450V
	Speed(Hi/Med/Lo)	r/min	1370/1300/1225	1370/1300/1225	1315/1200/1120
Indoor coil	Number of rows		2	3	3
	Tube pitch(a)x row pitch(b)	mm	21x13.37	21x13.37	21x13.37
	Fin spacing	mm	1,3	1,3	1,3
	Fin type		Hydrophilic aluminium	Hydrophilic aluminium	Hydrophilic aluminium
	Tube outside dia.and type	mm	Φ7,innergroove tube	Φ7,innergroove tube	Φ7,innergroove tube
	Coil length x height x width	mm	935x294x26.74	1010x294x40.11	1300x294x40.11
	Number of circuits		6	9	10
Indoor air flow(Hi/Med/Lo)		m ³ /h	1819/1536/1331	1750/1400/1250	2300/1800/1600
Indoor noise level (sound pressure)(Hi/Med/Lo)		dB(A)	53.6/50.0/47.1	53/48/44	55/49/46
Throttle type			/	/	/
Indoor unit	Dimension (WxDxH)	mm	1285x675x235	1285x675x235	1650x675x235
	Packing (WxDxH)	mm	1360x755x313	1360x755x313	1725x755x313
	Net/Gross weight	kg	29.9/35.5	31/36	39/45
Design pressure		MPa	4.2/1.5	4.2/1.5	4.2/1.5
Drainage water pipe diameter		mm	ODΦ25	ODΦ25	ODΦ25
Refrigerant piping	Liquid side/Gas side	mm(inch)	Φ9.52/Φ19(3/8"/3/4")	Φ12.7/Φ19	Φ12.7/Φ19
Controller			RG36C/BG(C)E	RG36C/BG(C)E	RG36C/BG(C)E
Operation temperature		°C	17~30	17~30	17~30
Room temperature	Cooling	°C	17~32	17~32	17~32
	Heating	°C	0~30	0~30	0~30

3. Dimensions

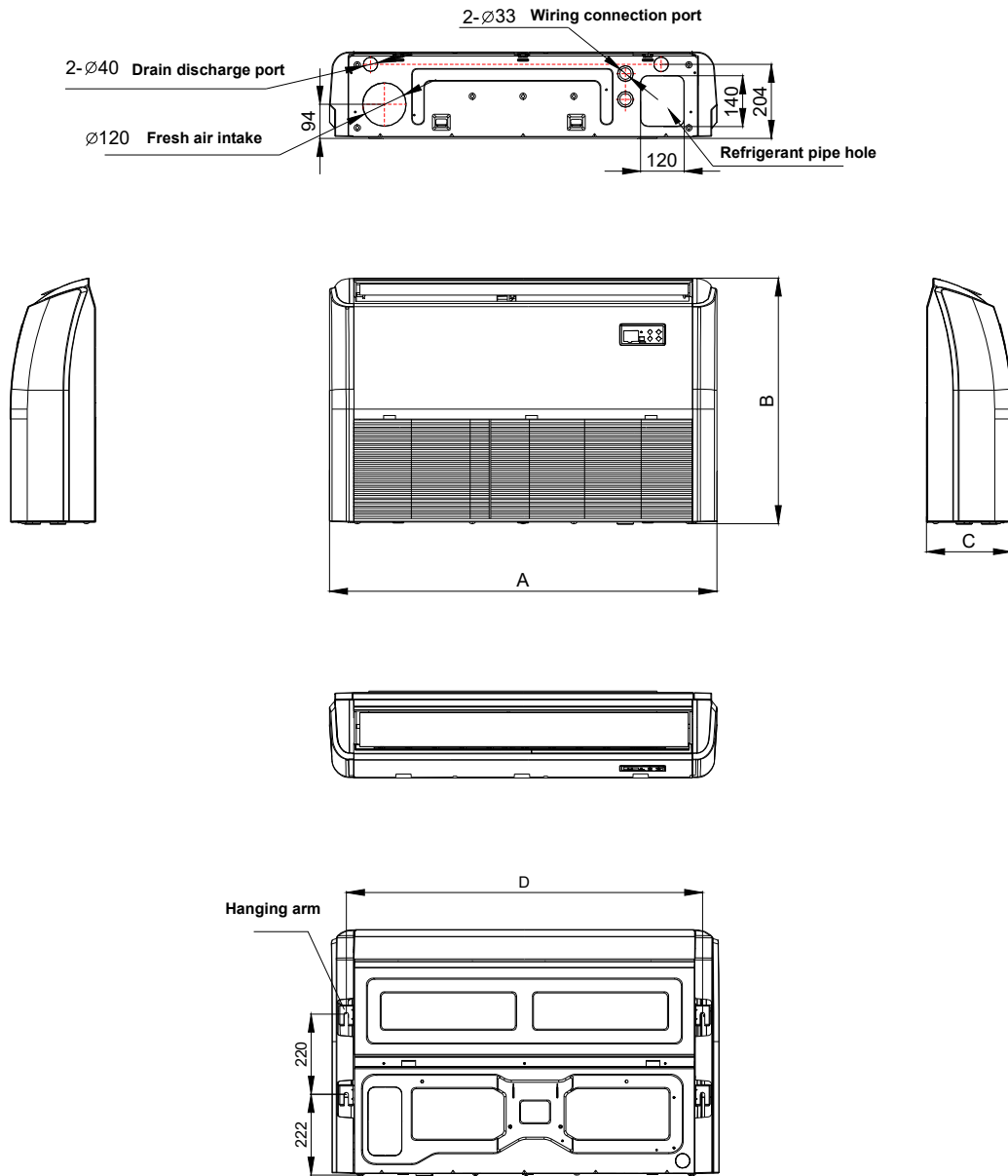

Capacity (Btu/h)	A	B	C	D
12~24K	1068	675	235	983
36K	1285	675	235	1200
48~60K	1650	675	235	1565

4. Service Space

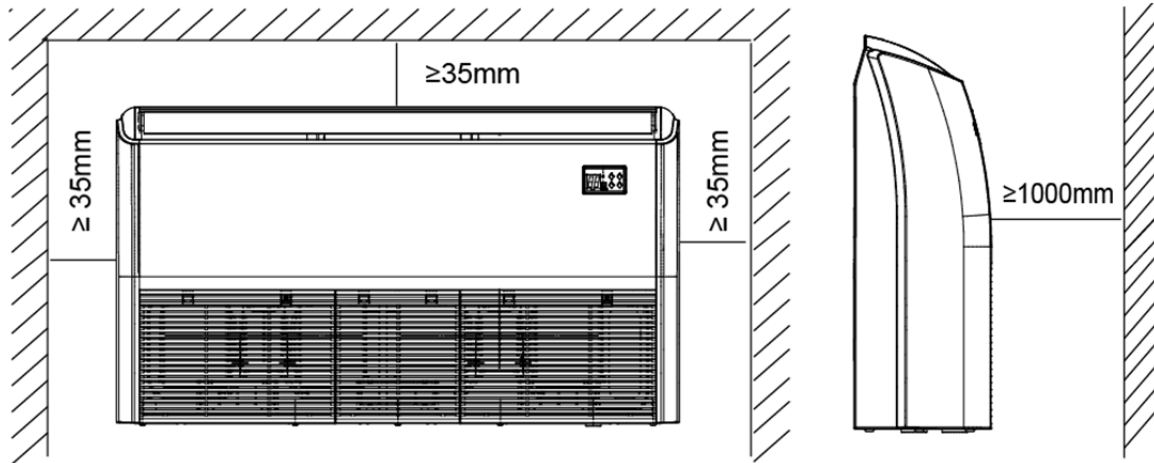

5. Capacity tables

5.1. MUE-12HRN1-Q1 / MOBA30U-12HN1-Q

COOLING		OUTDOOR TEMPERATURE DRY					
Indoor Conditions		21°C	25°C	30°C	35°C	40°C	45°C
21°C D 15°C W	Total capacity kW	3,39	3,36	3,32	3,26	2,61	2,44
	Sensitive capacity kW	2,71	2,68	2,66	2,61	2,08	1,95
	Input kW.	3,66	3,63	3,60	3,53	3,64	3,78
24°C D 17°C W	Total capacity kW	3,46	3,43	3,40	3,33	2,66	2,50
	Sensitive capacity kW	2,77	2,74	2,72	2,66	2,13	2,00
	Input kW.	1,36	1,35	1,34	1,32	1,36	1,41
27°C D 19°C W	Total capacity kW	3,81	3,77	3,73	3,66	2,93	2,75
	Sensitive capacity kW	3,05	3,02	2,99	2,93	2,34	2,20
	Input kW.	1,40	1,39	1,38	1,35	1,39	1,44
32°C D 23°C W	Total capacity kW	4,26	4,22	4,18	4,10	3,28	3,07
	Sensitive capacity kW	3,41	3,38	3,34	3,28	2,62	2,46
	Input kW.	1,56	1,55	1,54	1,51	1,56	1,62

HEATING		OUTDOOR CONDITIONS						
Indoor Conditions		24°C D 18°C W	12°C D 11°C W	7°C D 6°C W	4°C D 3°C W	0°C D -1°C W	-5°C D -6°C W	-7°C D -8°C W
15°C	Capacity kW	4,88	4,83	4,23	3,47	2,96	2,33	2,16
	Input kW.	1,64	1,62	1,42	1,31	1,28	1,13	1,10
18°C	Capacity kW	4,66	4,61	4,04	3,31	2,83	2,22	2,06
	Input kW.	1,56	1,55	1,35	1,25	1,22	1,08	1,05
20°C	Capacity kW	4,40	4,35	3,81	3,12	2,67	2,10	1,94
	Input kW.	1,48	1,46	1,28	1,19	1,16	1,02	0,99
22°C	Capacity kW	3,74	3,70	3,24	2,66	2,27	1,78	1,65
	Input kW.	1,36	1,35	1,18	1,09	1,07	0,94	0,91
27°C	Capacity kW	3,74	3,70	3,24	2,66	2,27	1,78	1,65
	Input kW.	1,38	1,36	1,19	1,10	1,08	0,95	0,92

5.2. MUE-18HRN1-Q1 / MOBA30U-18HN1-Q

COOLING		OUTDOOR TEMPERATURE DRY					
Indoor Conditions		21°C	25°C	30°C	35°C	40°C	45°C
21°C D 15°C W	Total capacity kW	5,02	4,97	4,92	4,82	3,86	3,62
	Sensitive capacity kW	4,01	3,97	3,94	3,86	3,09	2,89
	Input kW.	5,41	5,38	5,33	5,23	5,39	5,60
24°C D 17°C W	Total capacity kW	5,13	5,08	5,03	4,93	3,95	3,70
	Sensitive capacity kW	4,10	4,06	4,02	3,95	3,16	2,96
	Input kW.	2,13	2,12	2,10	2,06	2,12	2,20
27°C D 19°C W	Total capacity kW	5,64	5,58	5,53	5,42	4,34	4,07
	Sensitive capacity kW	4,51	4,47	4,42	4,34	3,47	3,25
	Input kW.	2,18	2,17	2,15	2,11	2,17	2,26
32°C D 23°C W	Total capacity kW	6,31	6,25	6,19	6,07	4,86	4,55
	Sensitive capacity kW	5,05	5,00	4,95	4,86	3,89	3,64
	Input kW.	2,45	2,43	2,41	2,36	2,43	2,53

HEATING		OUTDOOR CONDITIONS						
Indoor Conditions		24°C D 18°C W	12°C D 11°C W	7°C D 6°C W	4°C D 3°C W	0°C D -1°C W	-5°C D -6°C W	-7°C D -8°C W
15°C	Capacity kW	7,14	7,06	6,18	5,07	4,33	3,40	3,15
	Input kW.	2,21	2,19	1,92	1,77	1,73	1,53	1,49
18°C	Capacity kW	6,82	6,74	5,90	4,84	4,13	3,25	3,01
	Input kW.	2,11	2,09	1,83	1,69	1,65	1,46	1,42
20°C	Capacity kW	6,43	6,36	5,57	4,57	3,90	3,06	2,84
	Input kW.	2,00	1,98	1,73	1,60	1,56	1,38	1,34
22°C	Capacity kW	5,47	5,41	4,73	3,88	3,31	2,60	2,41
	Input kW.	1,84	1,82	1,60	1,48	1,44	1,27	1,24
27°C	Capacity kW	5,47	5,41	4,73	3,88	3,31	2,60	2,41
	Input kW.	1,86	1,84	1,61	1,49	1,45	1,28	1,25

5.3. MUE-24HRN1-Q1 / MOCA30U-24HN1-Q

COOLING		OUTDOOR TEMPERATURE DRY					
Indoor Conditions		21°C	25°C	30°C	35°C	40°C	45°C
21°C D 15°C W	Total capacity kW	6,51	6,44	6,38	6,26	5,01	4,69
	Sensitive capacity kW	5,21	5,16	5,11	5,01	4,00	3,75
	Input kW.	7,02	6,97	6,92	6,78	6,99	7,26
24°C D 17°C W	Total capacity kW	6,65	6,59	6,53	6,40	5,12	4,80
	Sensitive capacity kW	5,32	5,27	5,22	5,12	4,09	3,84
	Input kW.	2,66	2,64	2,62	2,57	2,64	2,75
27°C D 19°C W	Total capacity kW	7,31	7,24	7,17	7,03	5,62	5,27
	Sensitive capacity kW	5,85	5,79	5,74	5,62	4,50	4,22
	Input kW.	2,72	2,70	2,68	2,63	2,71	2,81
32°C D 23°C W	Total capacity kW	8,19	8,11	8,03	7,87	6,30	5,91
	Sensitive capacity kW	6,55	6,49	6,42	6,30	5,04	4,72
	Input kW.	3,05	3,03	3,00	2,95	3,03	3,15

HEATING		OUTDOOR CONDITIONS						
Indoor Conditions		24°C D 18°C W	12°C D 11°C W	7°C D 6°C W	4°C D 3°C W	0°C D -1°C W	-5°C D -6°C W	-7°C D -8°C W
15°C	Capacity kW	9,77	9,66	8,46	6,94	5,92	4,65	4,31
	Input kW.	3,14	3,10	2,71	2,51	2,45	2,16	2,10
18°C	Capacity kW	9,33	9,22	8,08	6,62	5,65	4,44	4,12
	Input kW.	2,99	2,96	2,59	2,40	2,34	2,06	2,01
20°C	Capacity kW	8,80	8,70	7,62	6,25	5,33	4,19	3,89
	Input kW.	2,83	2,80	2,45	2,27	2,21	1,95	1,90
22°C	Capacity kW	7,48	7,40	6,48	5,31	4,53	3,56	3,30
	Input kW.	2,61	2,58	2,26	2,09	2,04	1,80	1,75
27°C	Capacity kW	7,48	7,40	6,48	5,31	4,53	3,56	3,30
	Input kW.	2,63	2,60	2,28	2,11	2,06	1,82	1,77

5.4. MUE-36HRN1-R1/ MOD31U-36HN1-R

COOLING		OUTDOOR TEMPERATURE DRY					
Indoor Conditions		21°C	25°C	30°C	35°C	40°C	45°C
21°C D 15°C W	Total capacity kW	9,77	9,67	9,58	9,39	7,51	7,04
	Sensitive capacity kW	7,81	7,74	7,66	7,51	6,01	5,63
	Input kW.	10,54	10,47	10,38	10,18	10,49	10,89
24°C D 17°C W	Total capacity kW	9,98	9,89	9,79	9,60	7,68	7,20
	Sensitive capacity kW	7,99	7,91	7,83	7,68	6,14	5,76
	Input kW.	3,63	3,61	3,58	3,51	3,62	3,76
27°C D 19°C W	Total capacity kW	10,97	10,87	10,76	10,55	8,44	7,91
	Sensitive capacity kW	8,78	8,69	8,61	8,44	6,75	6,33
	Input kW.	3,73	3,70	3,67	3,60	3,71	3,85
32°C D 23°C W	Total capacity kW	12,29	12,17	12,05	11,82	9,45	8,86
	Sensitive capacity kW	9,83	9,74	9,64	9,45	7,56	7,09
	Input kW.	4,17	4,14	4,11	4,03	4,15	4,31

HEATING		OUTDOOR CONDITIONS						
Indoor Conditions		24°C D 18°C W	12°C D 11°C W	7°C D 6°C W	4°C D 3°C W	0°C D -1°C W	-5°C D -6°C W	-7°C D -8°C W
15°C	Capacity kW	13,53	13,37	11,71	9,60	8,20	6,44	5,97
	Input kW.	4,67	4,62	4,04	3,74	3,65	3,22	3,13
18°C	Capacity kW	12,92	12,77	11,18	9,17	7,83	6,15	5,70
	Input kW.	4,46	4,41	3,86	3,58	3,49	3,07	2,99
20°C	Capacity kW	12,19	12,05	10,55	8,65	7,39	5,80	5,38
	Input kW.	4,22	4,17	3,65	3,38	3,30	2,91	2,83
22°C	Capacity kW	10,36	10,24	8,97	7,35	6,28	4,93	4,57
	Input kW.	3,89	3,84	3,37	3,12	3,04	2,68	2,61
27°C	Capacity kW	10,36	10,24	8,97	7,35	6,28	4,93	4,57
	Input kW.	3,92	3,88	3,40	3,15	3,07	2,70	2,63

5.5. MUE-48HRN1-R / MOU-48HN1-R

COOLING		OUTDOOR TEMPERATURE DRY					
Indoor Conditions		21°C	25°C	30°C	35°C	40°C	45°C
21°C D 15°C W	Total capacity kW	13,02	12,90	12,77	12,52	10,02	9,39
	Sensitive capacity kW	10,42	10,32	10,22	10,02	8,01	7,51
	Input kW.	14,05	13,96	13,85	13,58	13,98	14,53
24°C D 17°C W	Total capacity kW	13,31	13,19	13,06	12,80	10,24	9,60
	Sensitive capacity kW	10,65	10,55	10,45	10,24	8,19	7,68
	Input kW.	5,11	5,07	5,03	4,94	5,08	5,28
27°C D 19°C W	Total capacity kW	14,63	14,49	14,35	14,07	11,25	10,55
	Sensitive capacity kW	11,70	11,59	11,48	11,25	9,00	8,44
	Input kW.	5,24	5,20	5,16	5,06	5,21	5,41
32°C D 23°C W	Total capacity kW	16,39	16,23	16,07	15,76	12,60	11,82
	Sensitive capacity kW	13,11	12,98	12,86	12,60	10,08	9,45
	Input kW.	5,87	5,83	5,78	5,67	5,84	6,06

HEATING		OUTDOOR CONDITIONS						
Indoor Conditions		24°C D 18°C W	12°C D 11°C W	7°C D 6°C W	4°C D 3°C W	0°C D -1°C W	-5°C D -6°C W	-7°C D -8°C W
15°C	Capacity kW	19,54	19,32	16,92	13,87	11,84	9,30	8,63
	Input kW.	6,48	6,41	5,61	5,19	5,07	4,47	4,35
18°C	Capacity kW	18,66	18,45	16,15	13,25	11,31	8,89	8,24
	Input kW.	6,19	6,12	5,36	4,96	4,84	4,26	4,15
20°C	Capacity kW	17,60	17,40	15,24	12,50	10,67	8,38	7,77
	Input kW.	5,85	5,78	5,06	4,69	4,57	4,03	3,92
22°C	Capacity kW	14,96	14,79	12,95	10,62	9,07	7,12	6,61
	Input kW.	5,39	5,33	4,67	4,32	4,22	3,72	3,62
27°C	Capacity kW	14,96	14,79	12,95	10,62	9,07	7,12	6,61
	Input kW.	5,44	5,38	4,71	4,36	4,26	3,75	3,65

5.6. MUE-60HRN1-R / MOUA-60HN1-R

COOLING		OUTDOOR TEMPERATURE DRY					
Indoor Conditions		21°C	25°C	30°C	35°C	40°C	45°C
21°C D 15°C W	Total capacity kW	14,92	14,78	14,63	14,35	11,48	10,76
	Sensitive capacity kW	11,94	11,82	11,71	11,48	9,18	8,61
	Input kW.	16,10	15,99	15,87	15,56	16,02	16,64
24°C D 17°C W	Total capacity kW	15,26	15,11	14,96	14,67	11,74	11,00
	Sensitive capacity kW	12,20	12,09	11,97	11,74	9,39	8,80
	Input kW.	6,46	6,42	6,37	6,24	6,43	6,68
27°C D 19°C W	Total capacity kW	16,76	16,60	16,44	16,12	12,90	12,09
	Sensitive capacity kW	13,41	13,28	13,15	12,90	10,32	9,67
	Input kW.	6,62	6,58	6,53	6,40	6,59	6,85
32°C D 23°C W	Total capacity kW	18,78	18,60	18,42	18,05	14,44	13,54
	Sensitive capacity kW	15,02	14,88	14,73	14,44	11,55	10,83
	Input kW.	7,42	7,37	7,31	7,17	7,38	7,67

HEATING		OUTDOOR CONDITIONS						
Indoor Conditions		24°C D 18°C W	12°C D 11°C W	7°C D 6°C W	4°C D 3°C W	0°C D -1°C W	-5°C D -6°C W	-7°C D -8°C W
15°C	Capacity kW	22,54	22,29	19,52	16,01	13,66	10,74	9,95
	Input kW.	7,42	7,34	6,43	5,95	5,80	5,12	4,98
18°C	Capacity kW	21,53	21,29	18,64	15,28	13,05	10,25	9,51
	Input kW.	7,09	7,01	6,14	5,68	5,54	4,88	4,76
20°C	Capacity kW	20,31	20,08	17,58	14,42	12,31	9,67	8,97
	Input kW.	6,70	6,62	5,80	5,37	5,24	4,62	4,50
22°C	Capacity kW	17,26	17,07	14,95	12,26	10,46	8,22	7,62
	Input kW.	6,18	6,11	5,35	4,95	4,83	4,26	4,14
27°C	Capacity kW	17,26	17,07	14,95	12,26	10,46	8,22	7,62
	Input kW.	6,24	6,17	5,40	5,00	4,88	4,30	4,18

6. Wiring Diagram

MUE-12HRN1-Q1, MUE-18HRN1-Q1

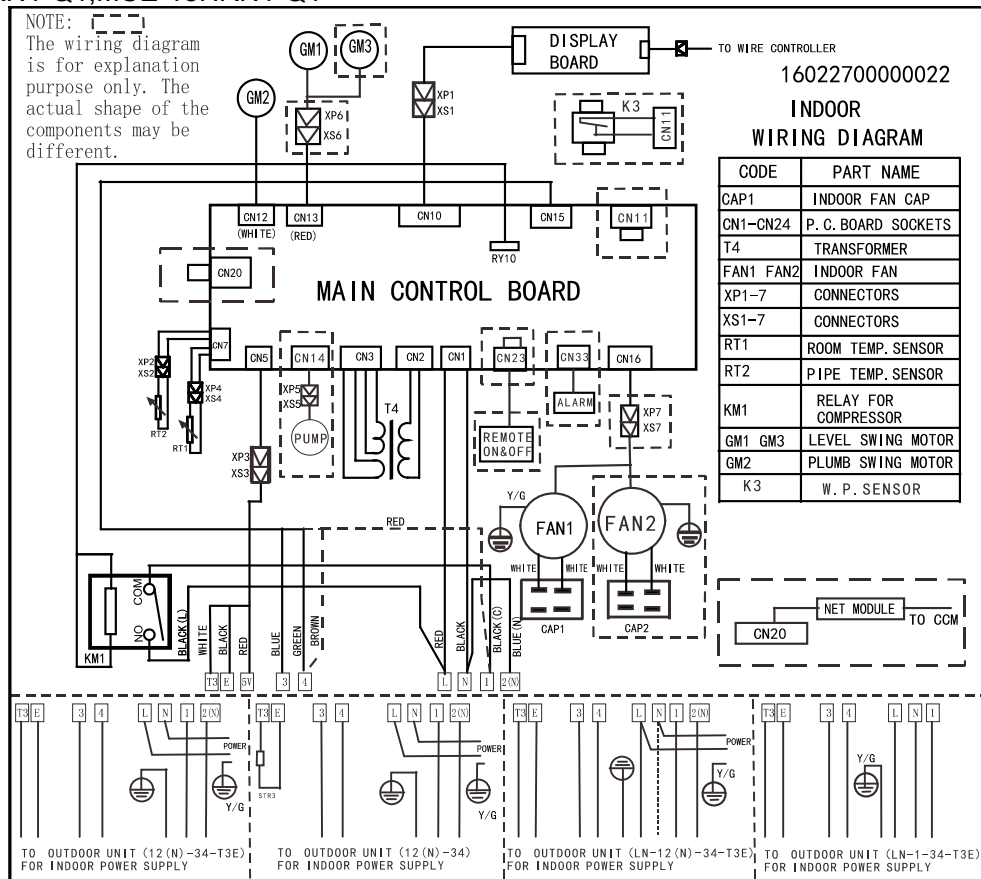

MUE-24HRN1-Q1

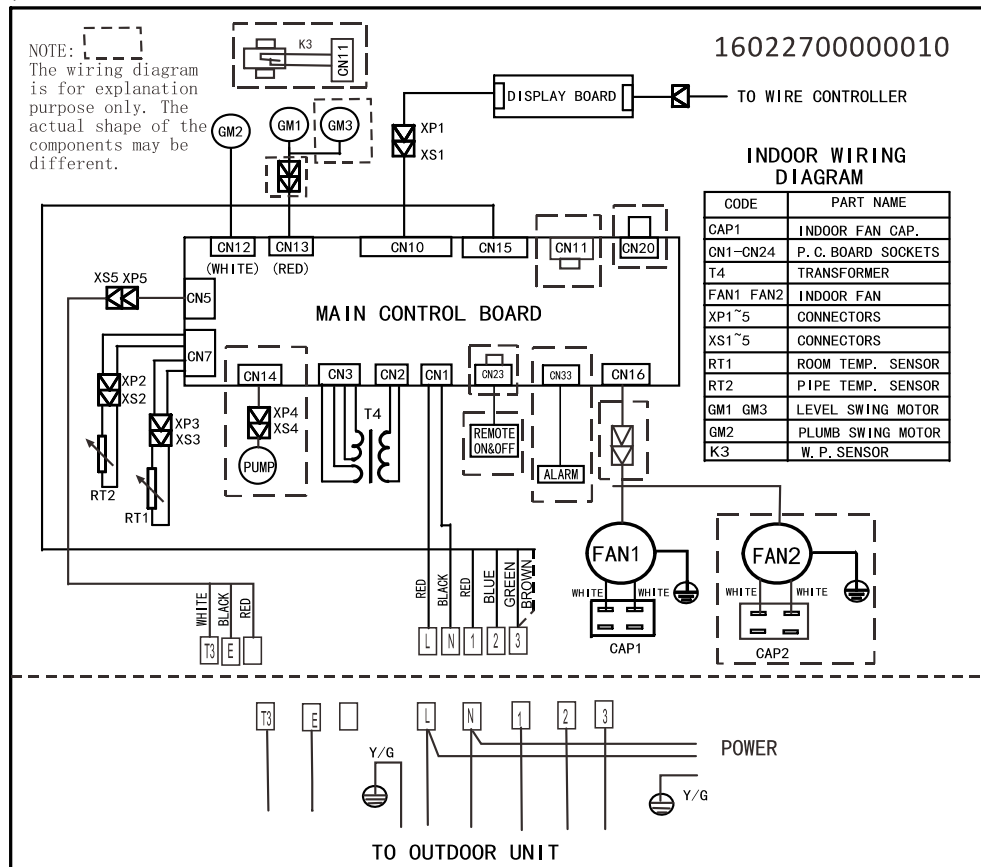

MUE-36HRN1-R1

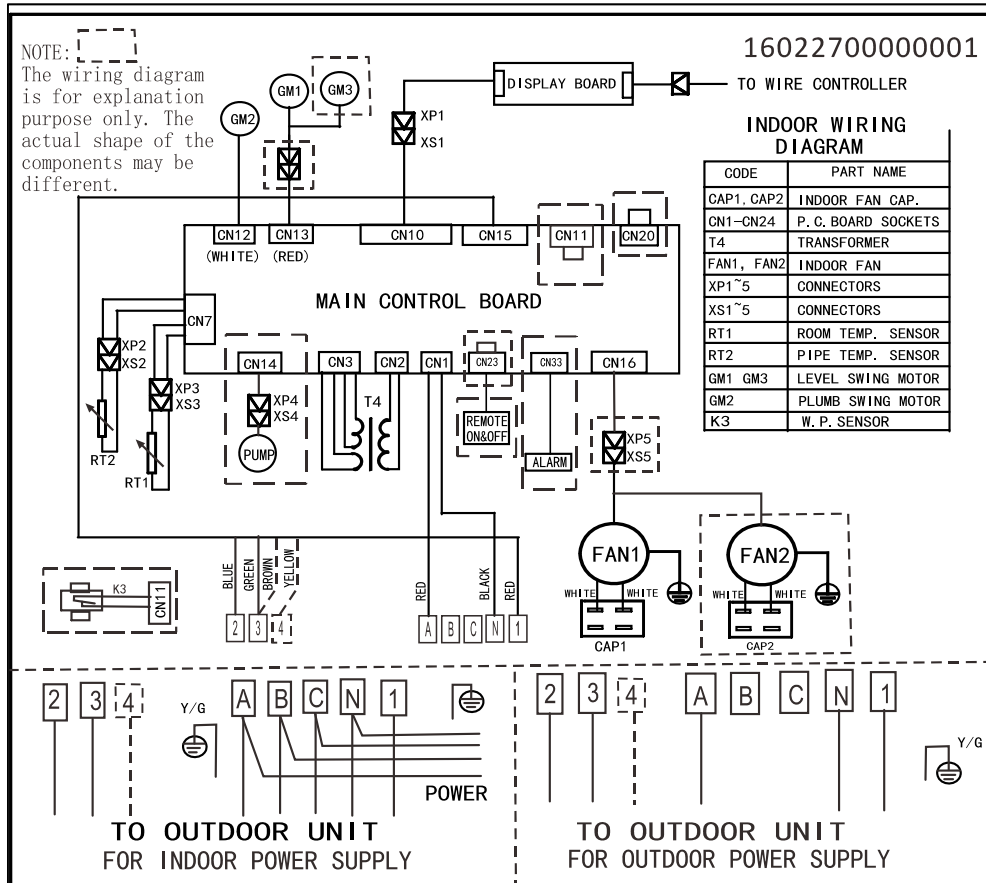

MUE-48HRN1-R, MUE-60HRN1-R

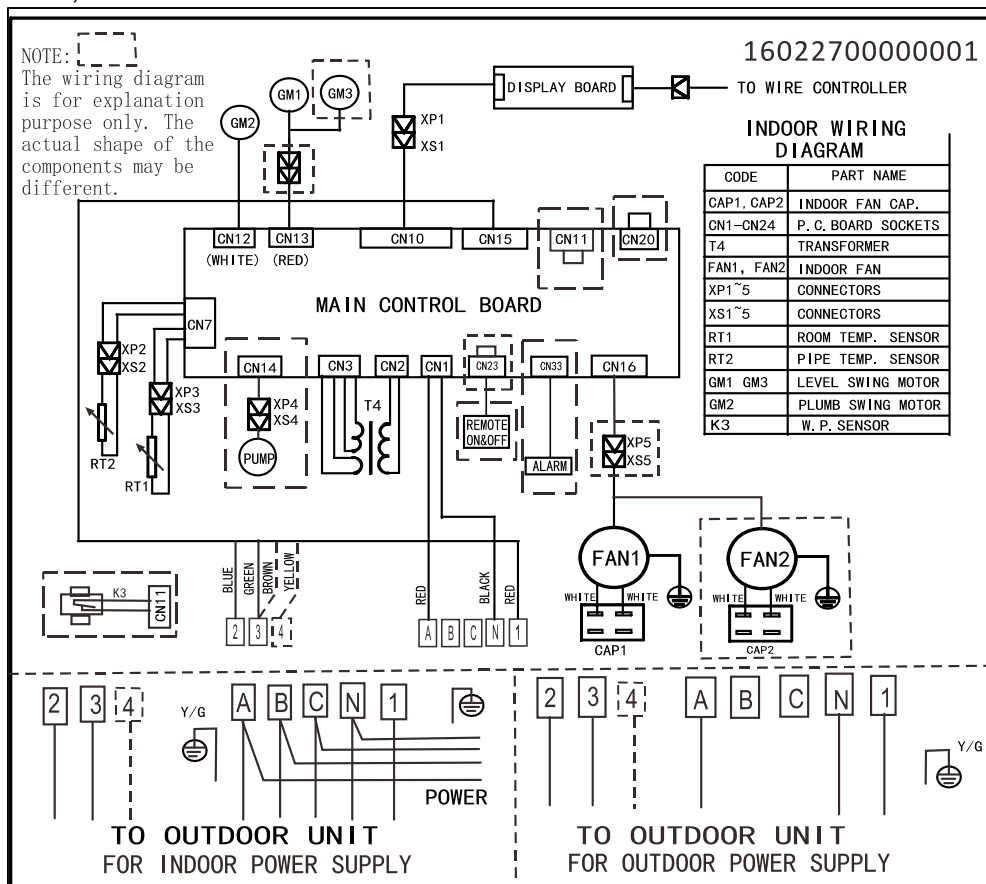

7. Electric Characteristics

Model	Indoor Units				Power Supply
	Hz	Voltage	Min.	Max.	MFA
MUE-12HRN1-Q1	50	220-240V	198V	242V	20
MUE-18HRN1-Q1	50	220-240V	198V	242V	20
MUE-24HRN1-Q1	50	220-240V	198V	242V	25
MUE-36HRN1-R1	50	220-240V	198V	242V	/
MUE-48HRN1-R	50	380-415V	342V	436V	25
MUE-60HRN1-R	50	380-415V	342V	436V	25

Remark:

MFA: Max. Fuse Amps. (A)

8. Sound Levels

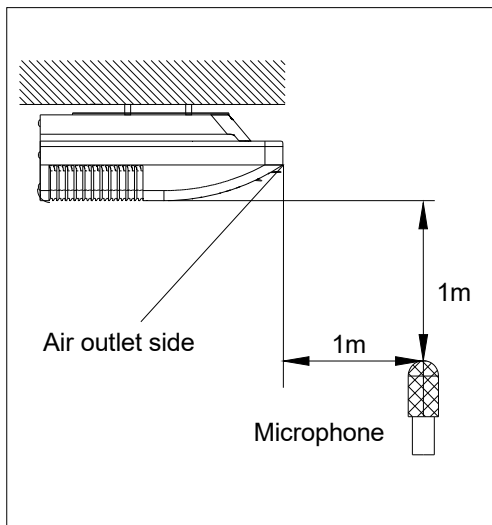

Ceiling

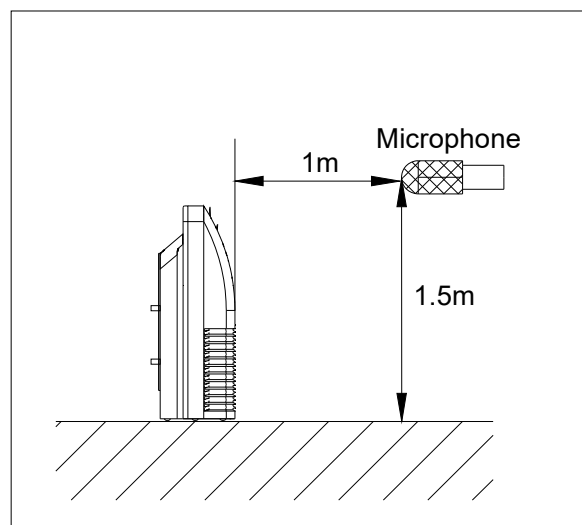

Floor

Model	Noise level dB(A)		
	H	M	L
MUE-12HRN1-Q1	37	33	30
MUE-18HRN1-Q1	53	48	43
MUE-24HRN1-Q1	54	48	44
MUE-36HRN1-R1	54	50	47
MUE-48HRN1-R	53	48	44
MUE-60HRN1-R	55	49	46

9. The Specification of Power

Model (KBtu/h)		18	24	36	48~60
Power	Phase	1-phase	1-phase	3-phase	3-phase
	Frequency and Voltage	220-240V, 50Hz		380-415V, 50Hz	
Circuit Breaker/ Fuse (A)		25/20	32/25	25/20	32/25
Indoor Unit Power Wiring (mm ²)		3×2.5	3×2.5	3×1.5	5×2.5
Indoor/Outdoor Wiring (mm ²)	Connecting				
	Ground Wiring	2.5	2.5	2.5	2.5
	Outdoor Unit Power Wiring	3×2.5	3×2.5	5×2.5	5×2.5
	Strong Electric Signal	2×1.0	3×1.0	3×1.0	3×1.0
	Weak Electric Signal	(2×0.75/ 2×0.5)	(2×0.2)	—————	—————

10. Field Wiring

MUE-12HRN1-Q1, MUE-18HRN1-Q1

Air Condition Link-Circuit

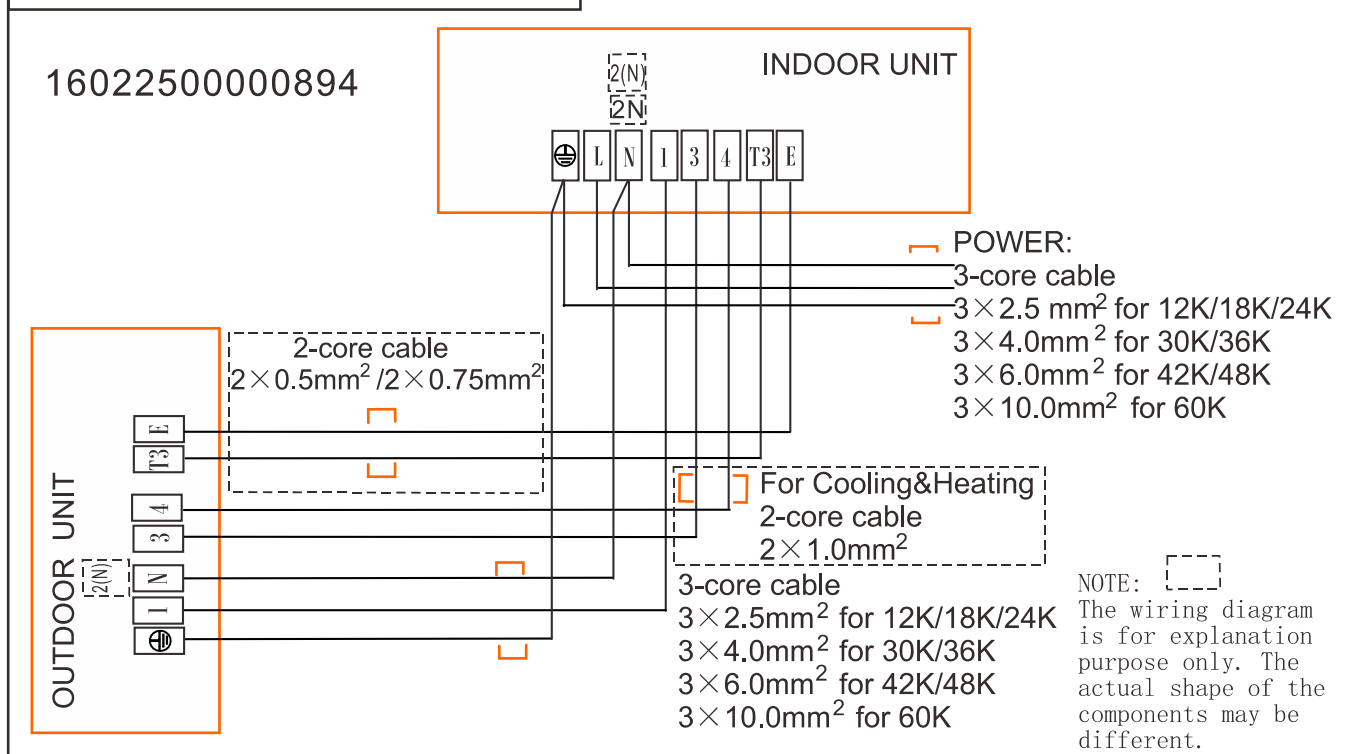

MUE-24HRN1-Q1

Air Condition Link-Circuit

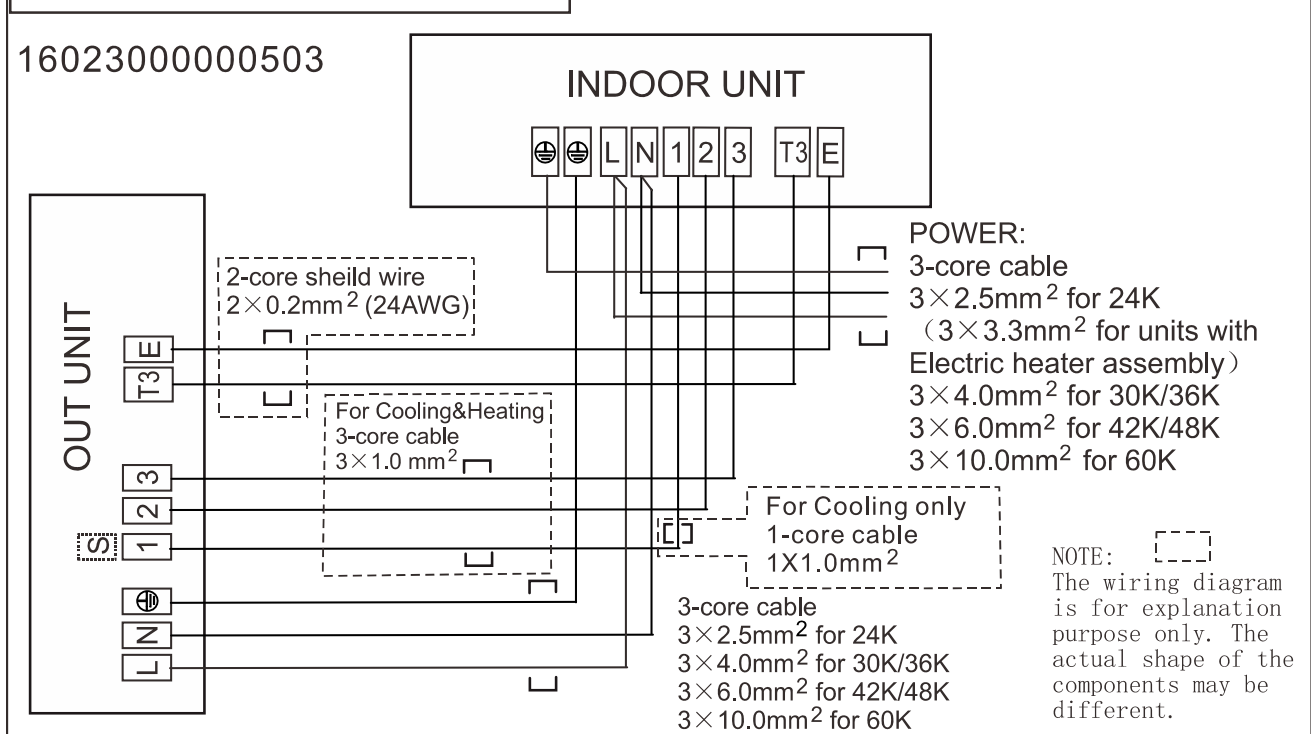

MUE-36HRN1-R1

Air Condition Link-Circuit

16022500000893

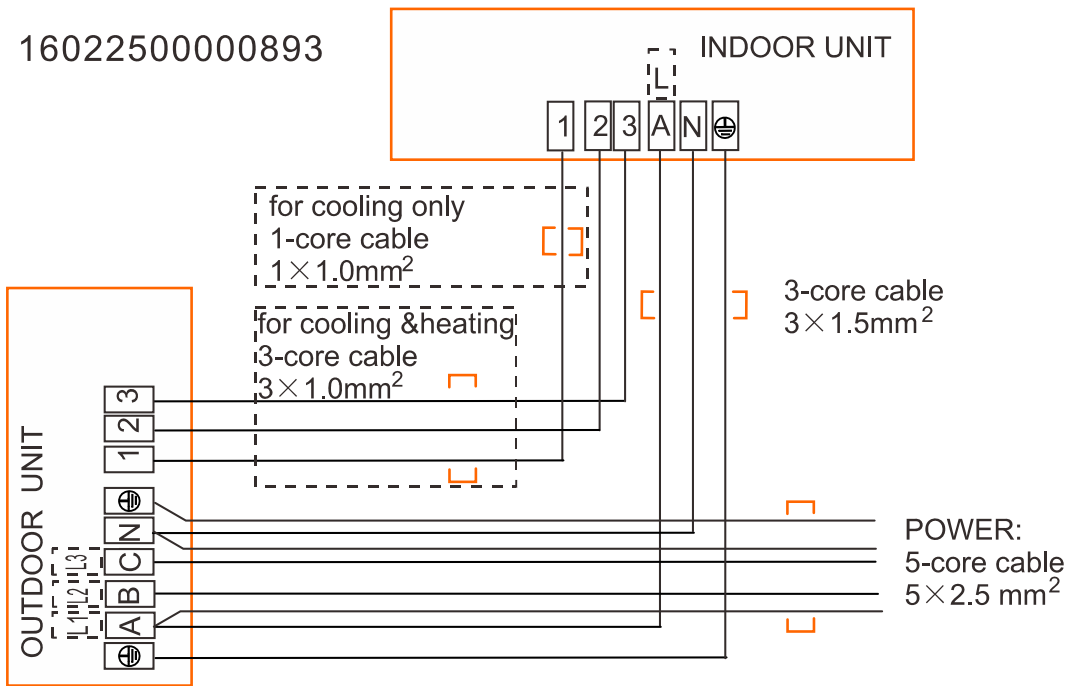

MUE-48HRN1-R, MUE-60HRN1-R

Air Condition Link-Circuit

16022500000890

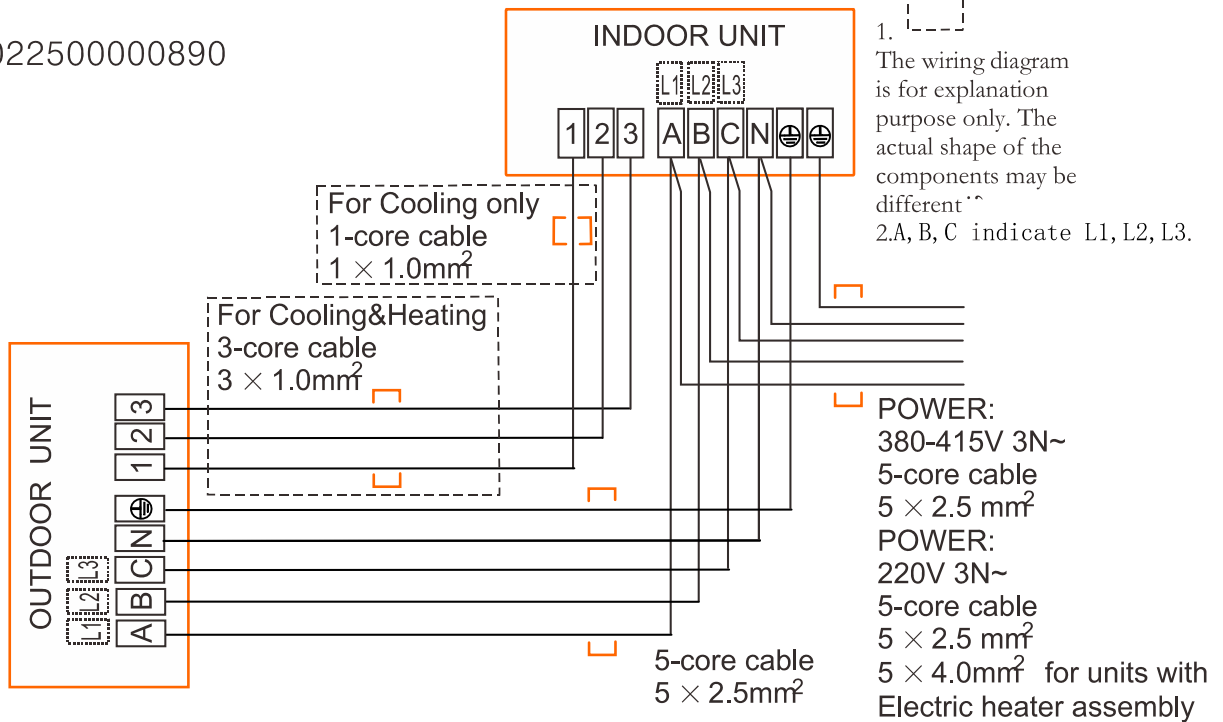

NOTE:

- The wiring diagram is for explanation purpose only. The actual shape of the components may be different.
- A, B, C indicate L1, L2, L3.

POWER:
380-415V 3N~
5-core cable
5 × 2.5 mm²
POWER:
220V 3N~
5-core cable
5 × 2.5 mm²
5 × 4.0mm² for units with
Electric heater assembly

Floor-standing Type

1. Features	106
2. Specification.....	107
3. Dimensions.....	107
4. Service Space.....	110
5. Capacity tables.....	107
6. Wiring Diagrams	111
7. Electric Characteristics	113
8. Sound Levels.....	114
9. The Specification of Power	115

1. Features

1.1. Fashionable design, concise and easy design better suits decoration style.



1.2. Dustproof Air Outlet

When press OFF to turn off the unit, the air outlet louver can be closed automatically to prevent the dust falling in.

1.3. Easy Control

Big LCD display shows multi-information very clearly.

Slight-touch buttons make the operation easy, clear and precise.

1.4. Comfortable Air Flow

Long distance air supply.

3D air distribution(Vertical and horizontal louvers auto swing)(optional)

2. Specification

Indoor		MFM-24ARN1-Q	
Outdoor		MOCA30U-24HN1-Q	
Power supply		V,Hz,Ph	220~240V,50Hz,1Ph
Cooling	Capacity	Btu/h	24000
	Input	W	2500
	Rated current	A	12,07
	EER	W/W	2,81
Heating	Capacity	Btu/h	26000+7000
	Input	W	2300+2300
	Rated current	A	11.11+10
	COP	W/W	3,31
Max. input consumption		W	3450+2300
Max. current		A	18+10
Starting current		A	59,0
Compressor	Model		PA291X3CS-4MTM1
	Type		ROTARY
	Brand		GMCC
	Capacity	Btu/h	24498/24669
	Input	W	2395/2540
	Rated current(RLA)	A	11.55/12.25
	Locked rotor Amp(LRA)	A	59
	Thermal protector		--
	Thermal protector position		INTERNAL
	Capacitor	uF	60UF/450V
	Refrigerant oil/oil charge	ml	ESTER OIL VG74 · 950
Indoor fan motor	Model		YKT-75-8-1-1
	Old Model		YDK75-8
	Input	W	166/145
	Capacitor	uF	5
	Speed(Hi/Mi/Lo)or (Hi/Lo)	r/min	540/440
Indoor coil	a.Number of rows		2
	b.Tube pitch(a)x row pitch(b)	mm	21x13.37
	c.Fin spacing	mm	1.3
	d.Fin type (code)		Hydrophilic aluminium
	e.Tube outside dia.and type	mm	Φ7,innergroovetube
	f.Coil length x height x width	mm	405x735x26.74
	g.Number of circuits		6
Indoor air flow (Hi/Mi/Lo) or (Hi/Lo)		m ³ /h	1154/1077
Indoor noise level (Hi/Mi/Lo)or (Hi/Lo)		dB(A)	48.6/42.9
Indoor unit	Dimension(W*D*H)	mm	500x315x1700
	Packing (W*D*H)	mm	1805x615x425
	Net/Gross weight	Kg	38.6/50.5
Outdoor fan motor	Model		YKT-75-6-200L
	Input	W	144
	Capacitor	uF	3UF/450V
	Speed	r/min	860
Outdoor coil	a.Number of rows		2
	b.Tube pitch(a)x row pitch(b)	mm	21x13.37
	c.Fin spacing	mm	1.2
	d.Fin type (code)		Hydrophilic aluminium
	e.Tube outside dia.and type	mm	Φ7,innergroove tube
	f.Coil length x height x width	mm	730x651x26.74
	g.Number of circuits		6
Outdoor noise level		dB(A)	61.1
Outdoor unit	Dimension(W*D*H)	mm	845x363x702
	Packing (W*D*H)	mm	965x395x755
	Net/Gross weight	Kg	52.7/56.1
Refrigerant type		g	R410A/1800
Design pressure		MPa	4.2/1.5
Refrigerant piping	Liquid side/ Gas side	mm(inch)	Φ9.52Φ15.9(3/8"/5/8")
	Max. refrigerant pipe length	m	25

	Max. difference in level	m	15
Connection wiring			3x2.5(Optional)
Plug type			--
Thermostat type			Remote Control
Operation temperature		°C	17-30
Room temperature	Indoor(cooling/ heating)	°C	17-32/0-30
	Outdoor(cooling/heating)	°C	18-43/-7-24
Application area		m ²	32-47

3. Dimensions

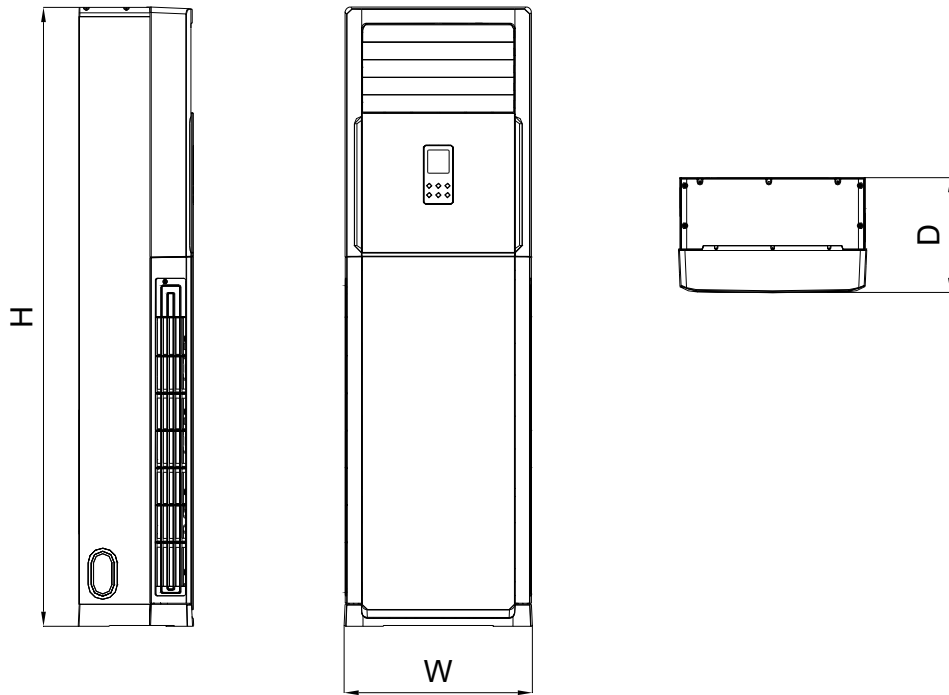

Model \ Dimension	W(mm)	D(mm)	H(mm)
24	500	315	1700

4. Service Space

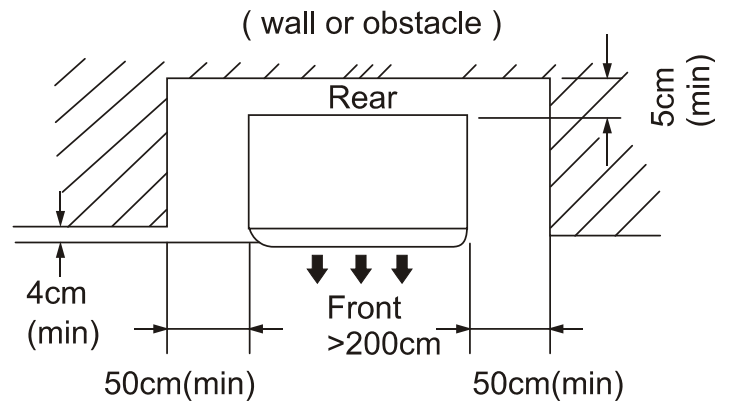
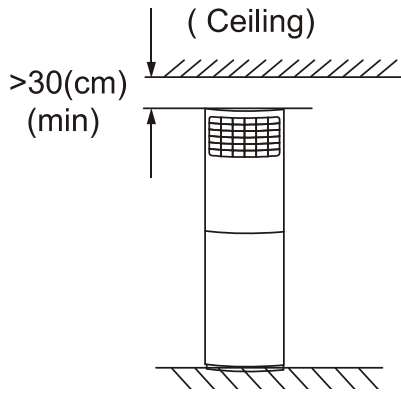

5. Capacity tables

5.1. MFM-24ARN1-Q / MOCA30U-24HN1-Q

COOLING		OUTDOOR TEMPERATURE DRY					
Indoor Conditions		21°C	25°C	30°C	35°C	40°C	45°C
21°C D 15°C W	Total capacity kW	6,51	6,45	6,39	6,26	5,01	4,70
	Sensitive capacity kW	5,21	5,16	5,11	5,01	4,01	3,76
	Input kW.	7,03	6,98	6,92	6,79	6,99	7,26
24°C D 17°C W	Total capacity kW	6,66	6,59	6,53	6,40	5,12	4,80
	Sensitive capacity kW	5,33	5,27	5,22	5,12	4,10	3,84
	Input kW.	2,52	2,51	2,49	2,44	2,51	2,61
27°C D 19°C W	Total capacity kW	7,32	7,25	7,17	7,03	5,63	5,28
	Sensitive capacity kW	5,85	5,80	5,74	5,63	4,50	4,22
	Input kW.	2,59	2,57	2,55	2,50	2,58	2,68
32°C D 23°C W	Total capacity kW	8,19	8,11	8,04	7,88	6,30	5,91
	Sensitive capacity kW	6,55	6,49	6,43	6,30	5,04	4,73
	Input kW.	2,90	2,88	2,86	2,80	2,88	3,00

HEATING		OUTDOOR CONDITIONS						
Indoor Conditions		24°C D 18°C W	12°C D 11°C W	7°C D 6°C W	4°C D 3°C W	0°C D -1°C W	-5°C D -6°C W	-7°C D -8°C W
15°C	Capacity kW	9,77	9,66	8,46	6,94	5,92	4,65	4,31
	Input kW.	2,94	2,91	2,55	2,36	2,30	2,03	1,98
18°C	Capacity kW	9,33	9,22	8,08	6,62	5,65	4,44	4,12
	Input kW.	2,81	2,78	2,43	2,25	2,20	1,94	1,89
20°C	Capacity kW	8,80	8,70	7,62	6,25	5,33	4,19	3,89
	Input kW.	2,66	2,63	2,30	2,13	2,08	1,83	1,78
22°C	Capacity kW	7,48	7,40	6,48	5,31	4,53	3,56	3,30
	Input kW.	2,45	2,42	2,12	1,96	1,91	1,69	1,64
27°C	Capacity kW	7,48	7,40	6,48	5,31	4,53	3,56	3,30
	Input kW.	2,47	2,45	2,14	1,98	1,93	1,70	1,66

6. Wiring Diagrams

MFM-24ARN1-Q

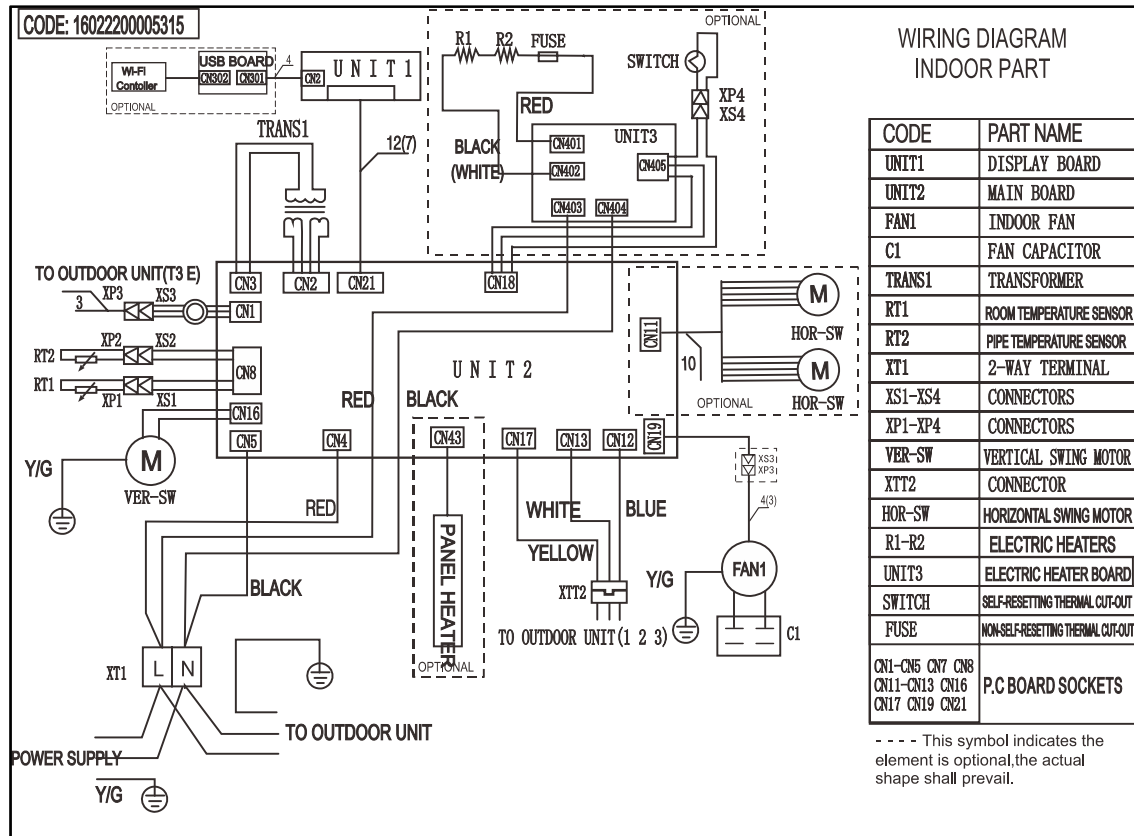

7. Electric Characteristics

Model	Indoor Units				Power Supply
	Hz	Voltage	Min.	Max.	MFA
MFM-24ARN1-Q	50	220-240V	198V	254V	25

Notes:

MFA: Max. Fuse Amps. (A)

8. Sound Levels

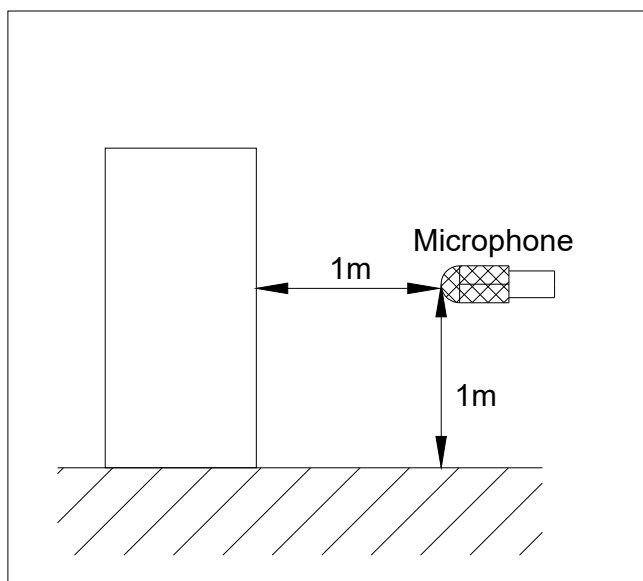

Model	Noise level dB(A)	
	H	L
MFM-24ARN1-Q	49	43

9. The Specification of Power

Model	Power supply	Input Rated Amp (Switch/Fuse)(A)	Power Cord Size
24000Btu/h	220-240V~ 50Hz	32/25	$\geq 2.5 \text{ mm}^2$ ($\geq 3.3 \text{ mm}^2$ for with PTC)

NOTE: The cable size and the current of the fuse or switch are determined by the maximum current indicated on the nameplate which located on the side panel of the unit. Please refer to the nameplate before selecting the cable, fuse and switch.

Part 3

Outdoor Units

1. Specification	117
2. Dimensions	121
3. Service Space	121
4. Piping Diagrams	122
5. Wiring Diagrams	124
6. Electric Characteristics	127
7. Operation Limits	128
8. Sound Levels	129

1. Specification

Model			MOBA30U-12HN1-Q	MOBA30U-18HN1-Q	MOCA30U-24HN1-Q
Power supply	V-ph-Hz		220-240-1-50	220-240-1-50	220-240-1-50
Max. input consumption	W		1800	2950	3450
Max. input current	A		8.5	15	18
Compressor	Model		ASM140V1VFT	PA215M2AS-7KTL6	PA291X3CS-4MTM1
	Type		ROTARY	ROTARY	ROTARY
	Brand		GMCC	GMCC	GMCC
	Capacity	Btu/h	13853/13853	21325	24498/24669
	Input	W	955/995	1525	2395/2540
	Rated current(RLA)	A	4.35/4.2	6.85	11.55/12.25
	Locked rotor Amp(LRA)	A	25	/	59
	Thermal protector position		INTERNAL	INTERNAL	INTERNAL
	Capacitor	μF	35UF/450V	50UF/450V	60UF/450V
Refrigerant oil	ml	ESTER OIL VG74/350	ESTER OIL VG74/620	ESTER OIL VG74 · 950	
Outdoor fan motor	Model		YKT-32-6-203L	YKT-48-6-206	YKT-75-6-200L
	Qty		1	1	1
	Input	W	72.5/67	91.8/79.2	144
	Capacitor	μF	2.5UF/450V	3UF/450V	3UF/450V
	Speed	r/min	850/770	890/830	860
Outdoor coil	Number of rows		1.6	2	2
	Tube pitch(a)* row pitch(b)	mm	21x13.37	21x13.37	21x13.37
	Fin spacing	mm	1.4	1.4	1.2
	Fin type		Hydrophilic aluminium	Hydrophilic aluminium	Hydrophilic aluminium
	Tube outside dia. and type	mm	Φ7, innergroove tube	Φ7, innergroove tube	Φ7, innergroove tube
	Coil length * height * width	mm	755x504x13.37+475x504x13.37	755x504x26.74	730x651x26.74
	Number of circuits		4	4	6
Outdoor noise level (sound pressure)	dB(A)		59	62	62
Throttle type			capillary	capillary	Throttle Valve
Outdoor unit	Dimension(WxDxH)	mm	770x300x555	770x300x555	845x363x702
	Packing(WxDxH)	mm	900x345x585	900x345x585	965x395x755
	Net/Gross weight	kg	30.5/32.9	36.5/38.8	52.7/56.1
Refrigerant type/Q-ty	Type		R410A	R410A	R410A
	Charged volume	kg	1.1	1.5	1.8
Design pressure	MPa		4.2/1.5	4.2/1.5	4.2/1.5
Refrigerant piping	Liquid side/ Gas side	mm(inc h)	Φ6.35/Φ12.7(1/4"/1/2")	Φ6.35/Φ12.7(1/4"/1/2")	Φ9.52Φ15.9(3/8"/5/8")
	Max. pipe length	m	18	25	25
	Max. difference in level	m	8	15	15
Ambient temperature	Cooling	°C	18-43	18-43	18-43
	Heating	°C	-7-24	-7-24	-7-24

Model			MOD31U-36HN1-R	MOU-48HN1-R	MOUA-60HN1-R
Power supply	V-ph-Hz		380~415-3-50	380-415-3-50	380-415-3-50
Max. input consumption	W		4250	6300	7500
Max. input current	A		7	11	12,6
Compressor	Model		ZP42KUE-TFM-52E	C-SBN373H8D	C-SBN453H8D
	Type		SCROLL	Scroll	Scroll
	Brand		EMERSON	Panasonic	Panasonic
	Capacity	Btu/h	10300W	48109	55956,8
	Input	W	3300	4750	5750
	Rated current(RLA)	A	5.9	8,22	9,77
	Locked rotor Amp(LRA)	A	51	66	67
	Thermal protector position		INTERNAL	Internal	Internal
	Capacitor	μF	/	/	/
Refrigerant oil	ml	1242	1700	1700	
Outdoor fan motor	Model		YKS-190-6-21L		
	Old Model		YKS-190-6-21L	YDK65-6F(B)	YDK65-6F(B)
	Qty		1	2	2
	Input	W	293.3/261	162	162
	Capacitor	μF	10	3.5UF/450V	3.5UF/450V
	Speed	r/min	846/760	765	765
Outdoor coil	Number of rows		2.6	2	2
	Tube pitch(a)* row pitch(b)	mm	21x13.37	21x13.37	22x19.05
	Fin spacing	mm	1.4	1,4	1,6
	Fin type		Unhydrophilic aluminium	Hydrophilic aluminium	Hydrophilic aluminium
	Tube outside dia.and type	mm	Φ7,innergroove tube	Φ7,innergroove tube	Φ7.94,innergroove tube
	Coil length * height * width	mm	1010x756x26.74+598x756x13.37	840x1113x26.74	837x1100x38.1
	Number of circuits		6	8	4
Outdoor noise level (sound pressure)	dB(A)		64.4	63	63
Throttle type			Throttle valve	Capillary	Capillary
Outdoor unit	Dimension(WxDxH)	mm	946x410x810	900x350x1170	900x350x1170
	Packing(WxDxH)	mm	1090x500x875	1032x443x1307	1032x443x1307
	Net/Gross weight	kg	77.1/82.9	93.2/105	97/108
Refrigerant type/Quantity	Type		R410A	R410A	R410A
	Charged volume	kg	2.5	3.25	3.2
Design pressure	MPa		4.2/1.5	4.2/1.5	4.2/1.5
Refrigerant piping	Liquid side/ Gas side	mm(inch)	Φ9.52/Φ19(3/8"/3/4")	Φ12.7/Φ19	Φ12.7/Φ19
	Max. pipe length	m	30	50	50
	Max. difference in level	m	20	30	30
Ambient temperature	Cooling	°C	18~43	18-43	18-43
	Heating	°C	-7~24	-7-24	-7-24

2. Dimensions

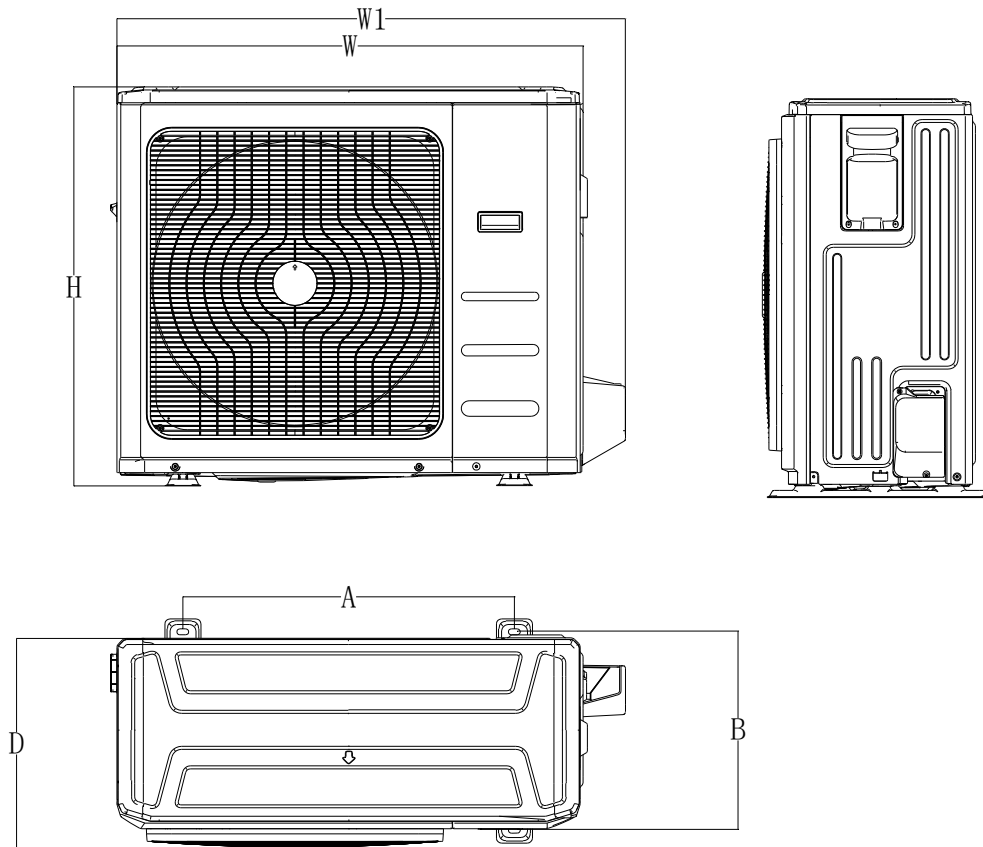

Model	Unit : mm					
	W	D	H	W1	A	B
MOBA30U-12HN1-Q	770	300	555	840	487	298
MOBA30U-18HN1-Q	770	300	555	840	487	298
MOCA30U-24HN1-Q	845	363	702	914	540	350
MOD31U-36HN1-R	946	410	810	1030	673	403

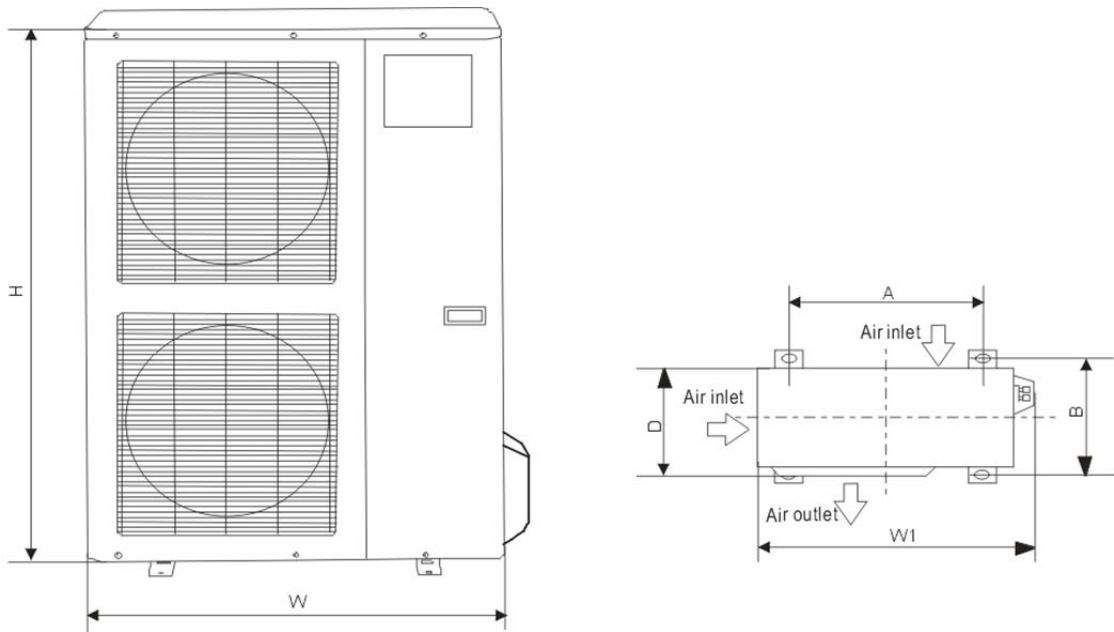

Model	Unit : mm					
	W	D	H	W1	A	B
MOU-48HN1-R	900	350	1170	985	590	378
MOUA-60HN1-R	900	350	1170	985	590	378

3. Service Space

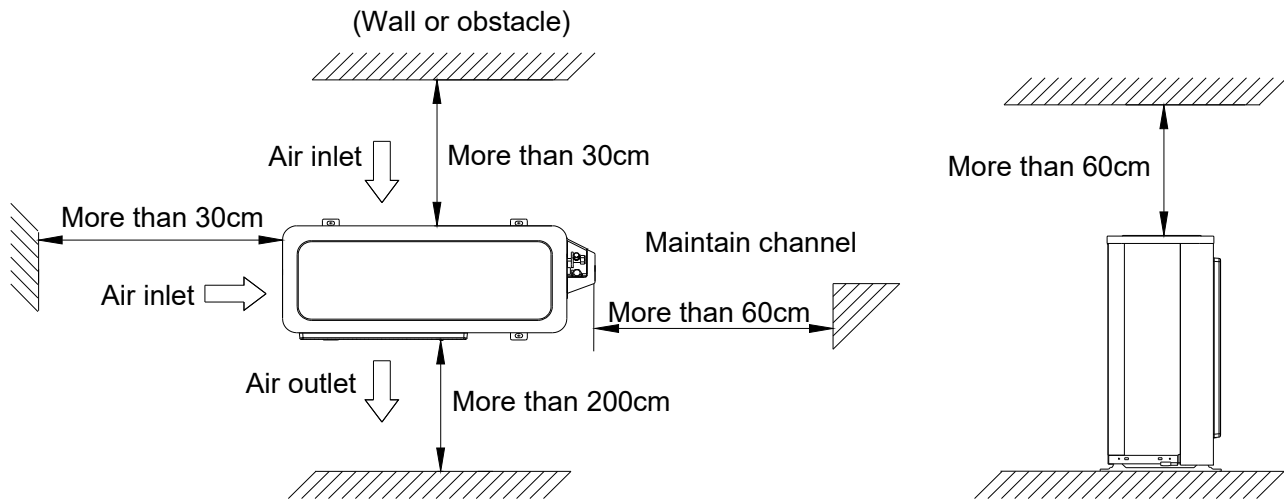

4. Piping Diagrams

MOBA30U-12HN1-Q, MOBA30U-18HN1-Q

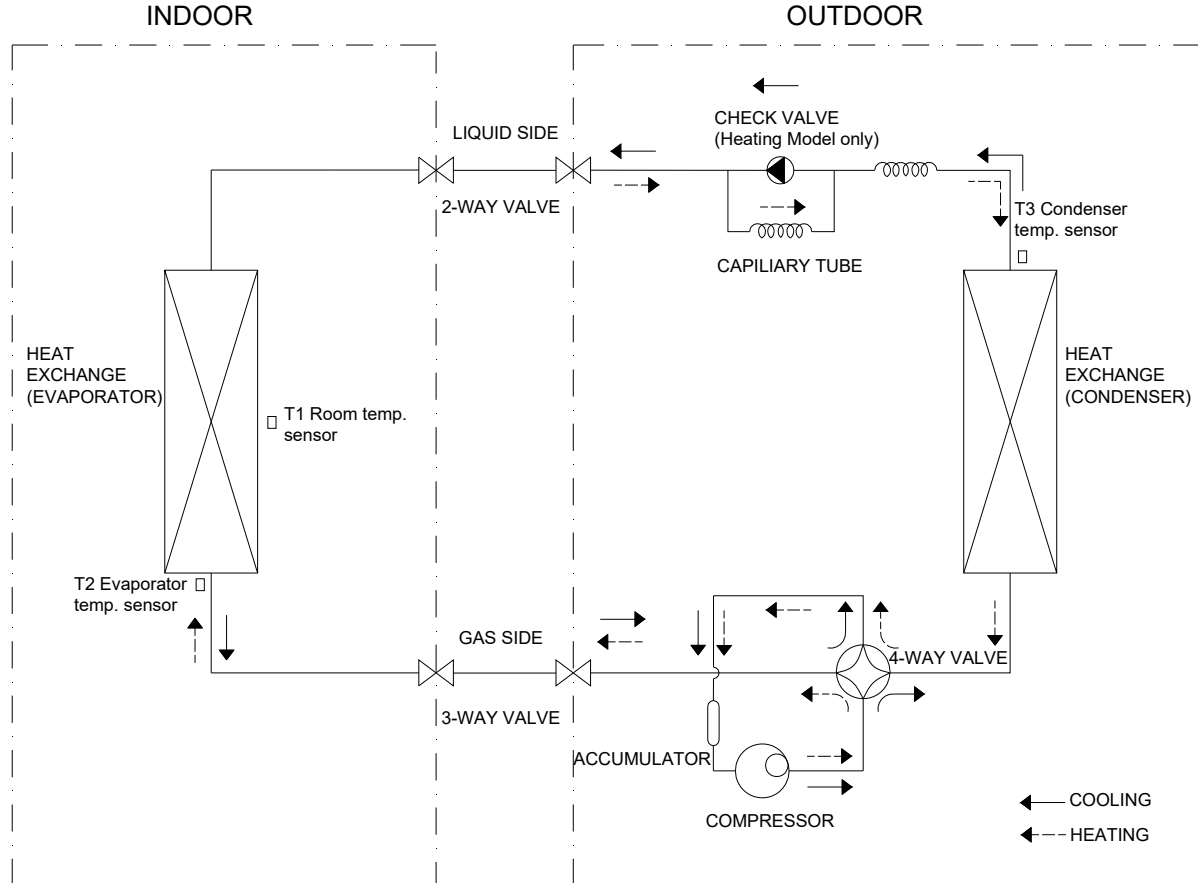

MOCA30U-24HN1-Q

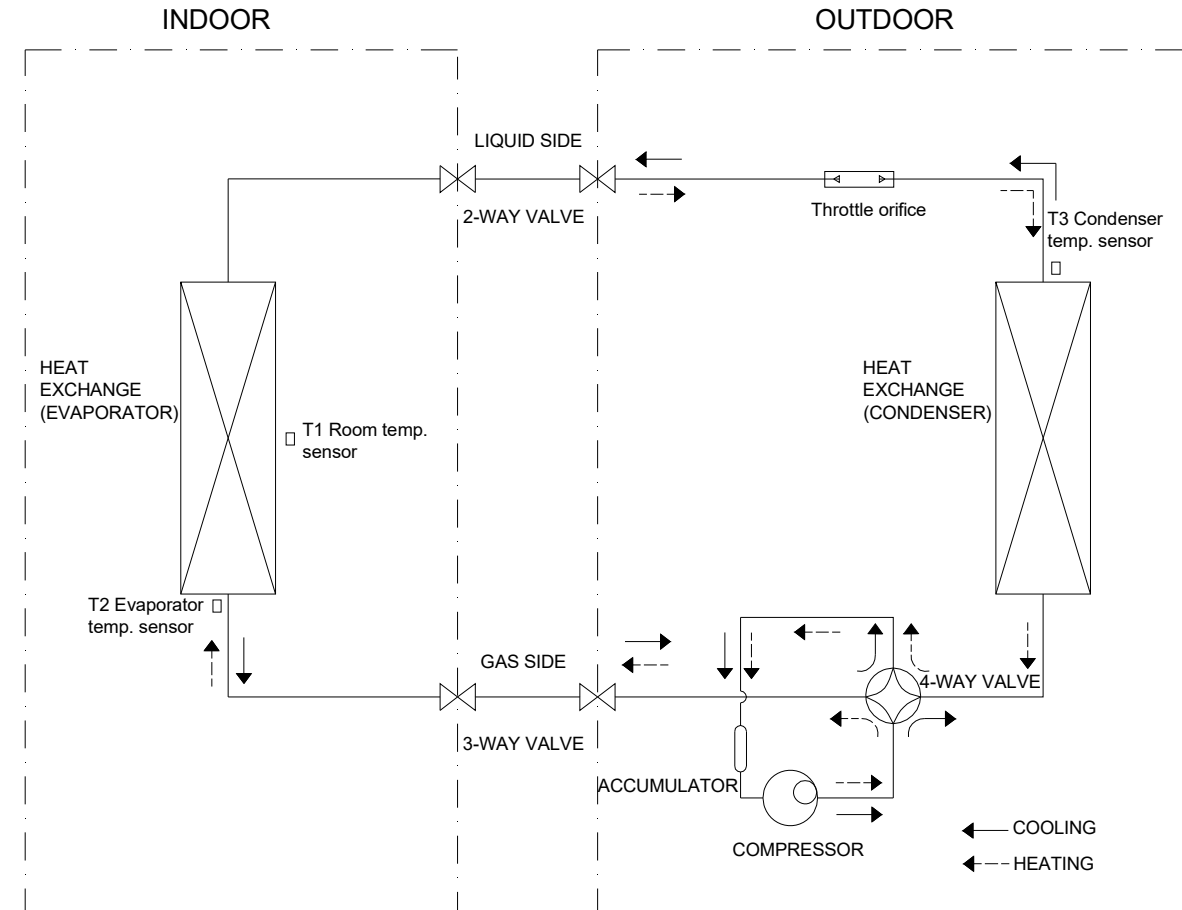

MOD31U-36HN1-R

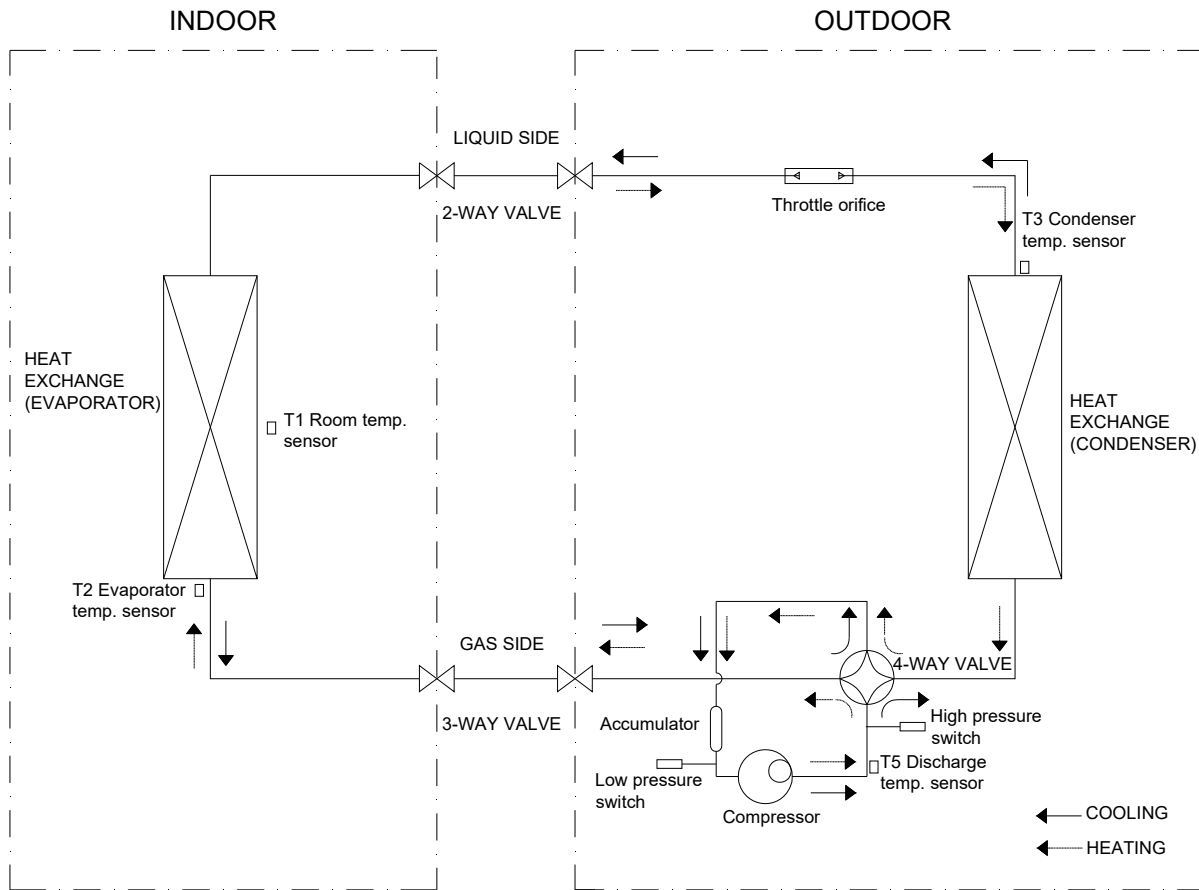

MOU-48HN1-R, MOUA-60HN1-R

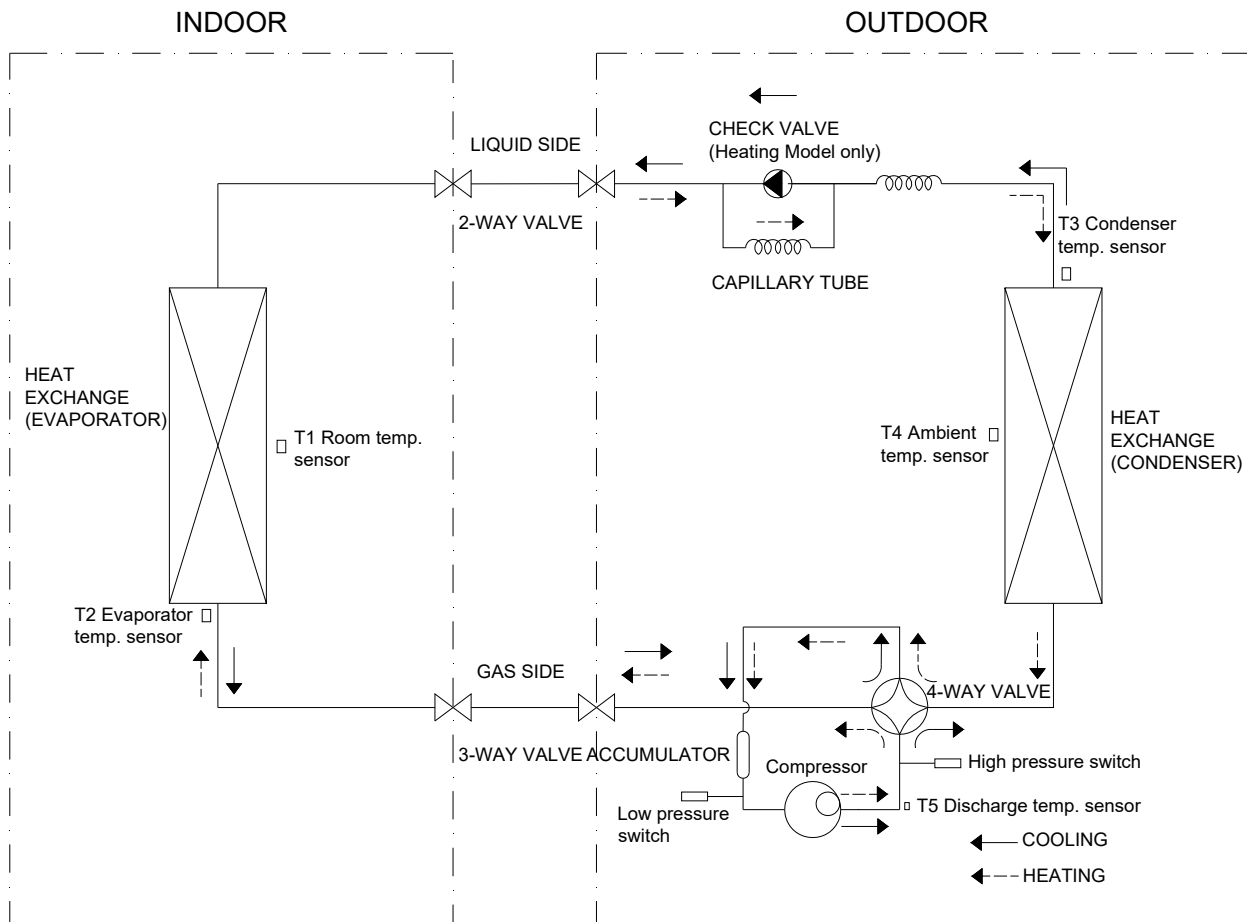

5. Wiring Diagrams

MOBA30U-12HN1-Q, MOBA30U-18HN1-Q

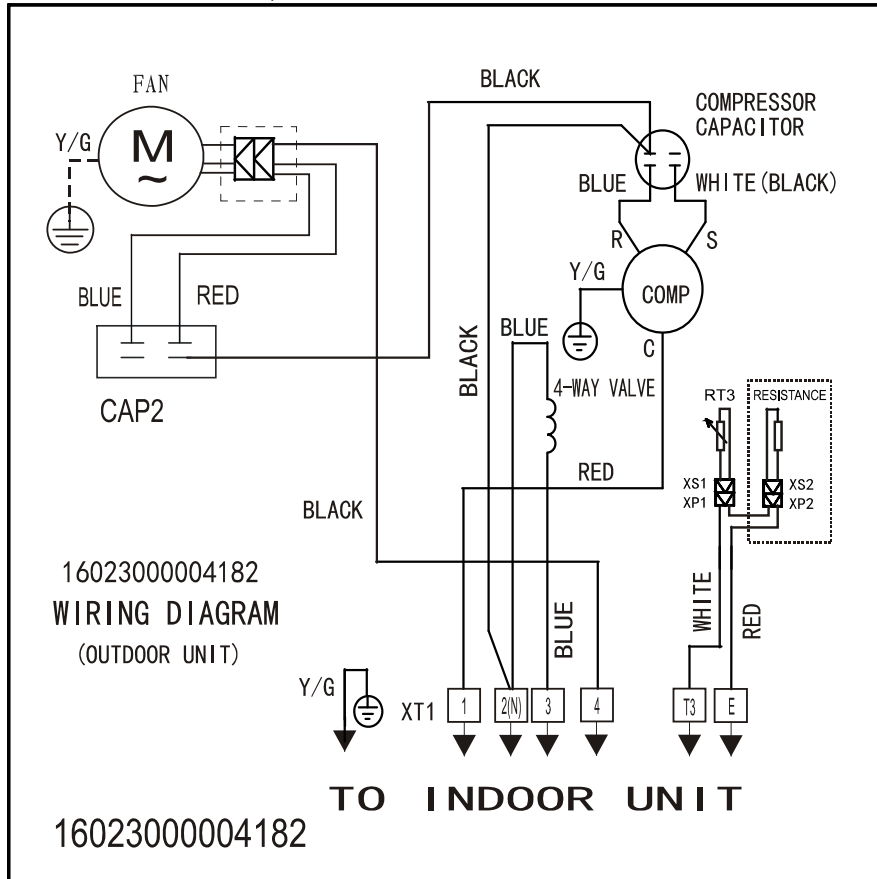

MOCA30U-24HN1-Q

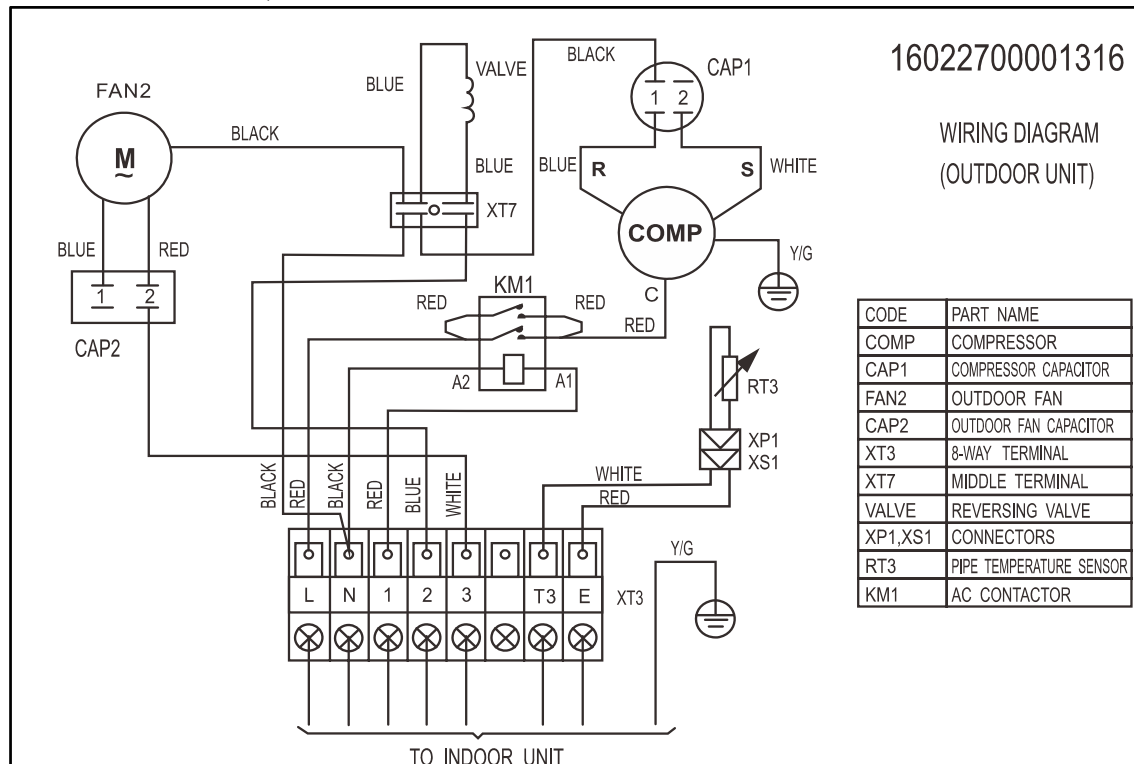

MOD31U-36HN1-R

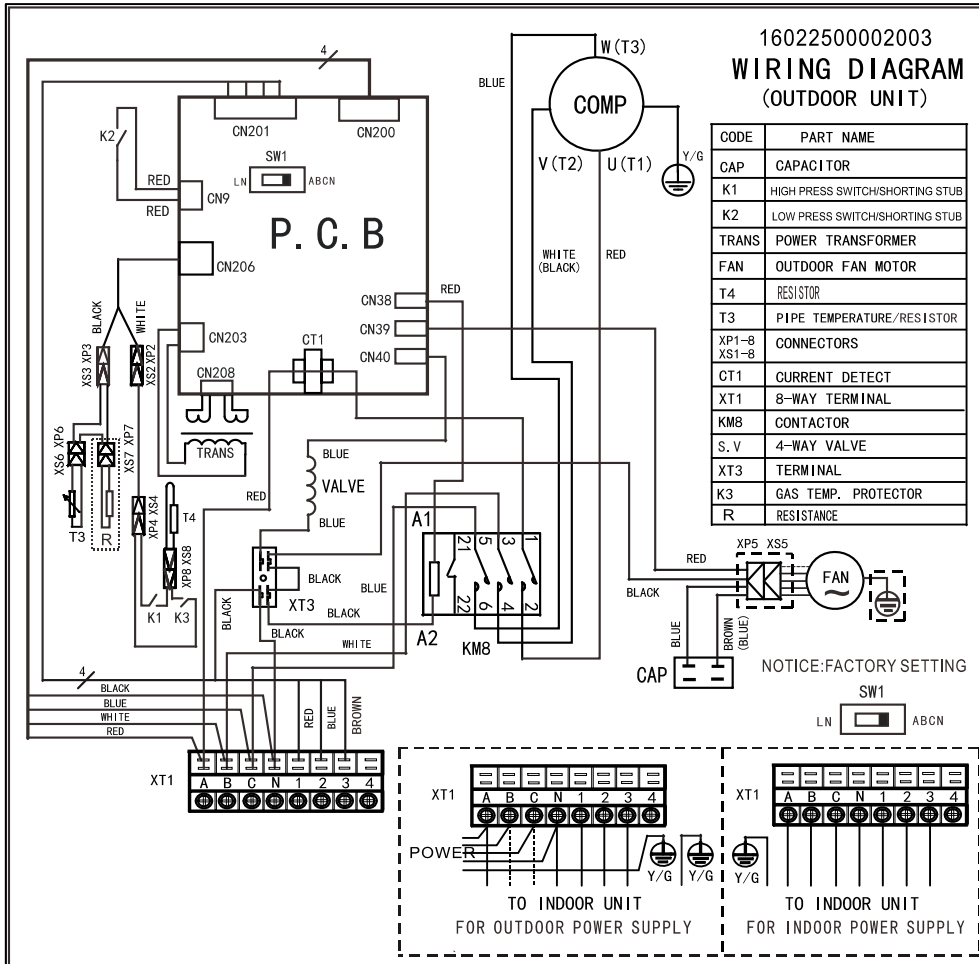

MOU-48HN1-R

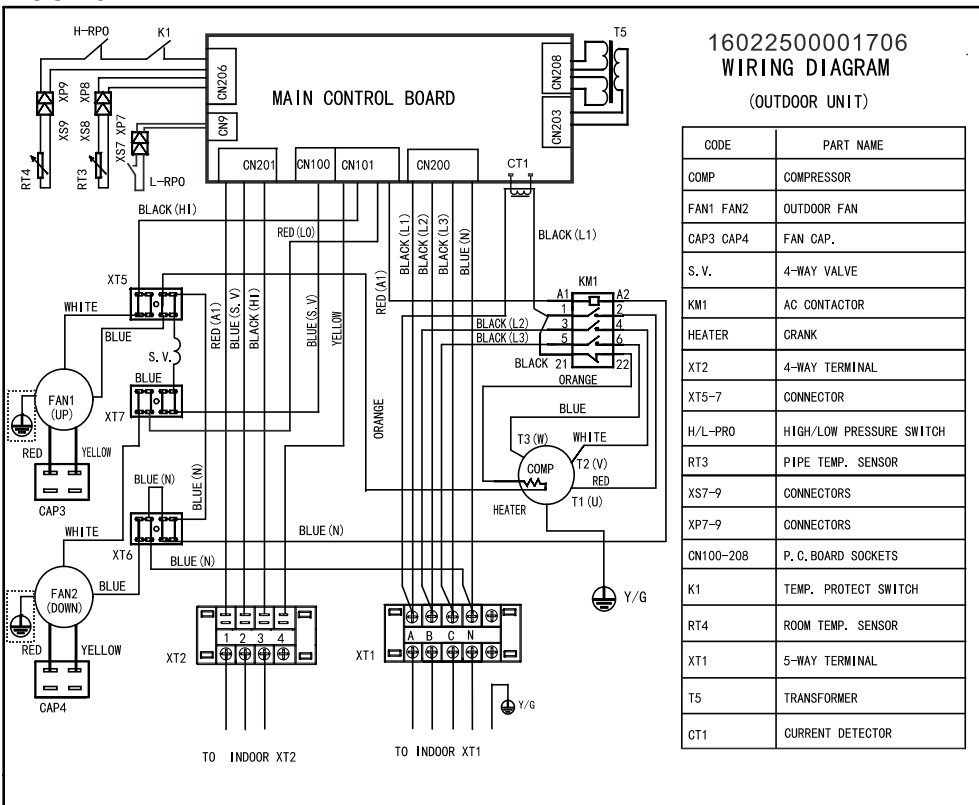

MOUA-60HN1-R

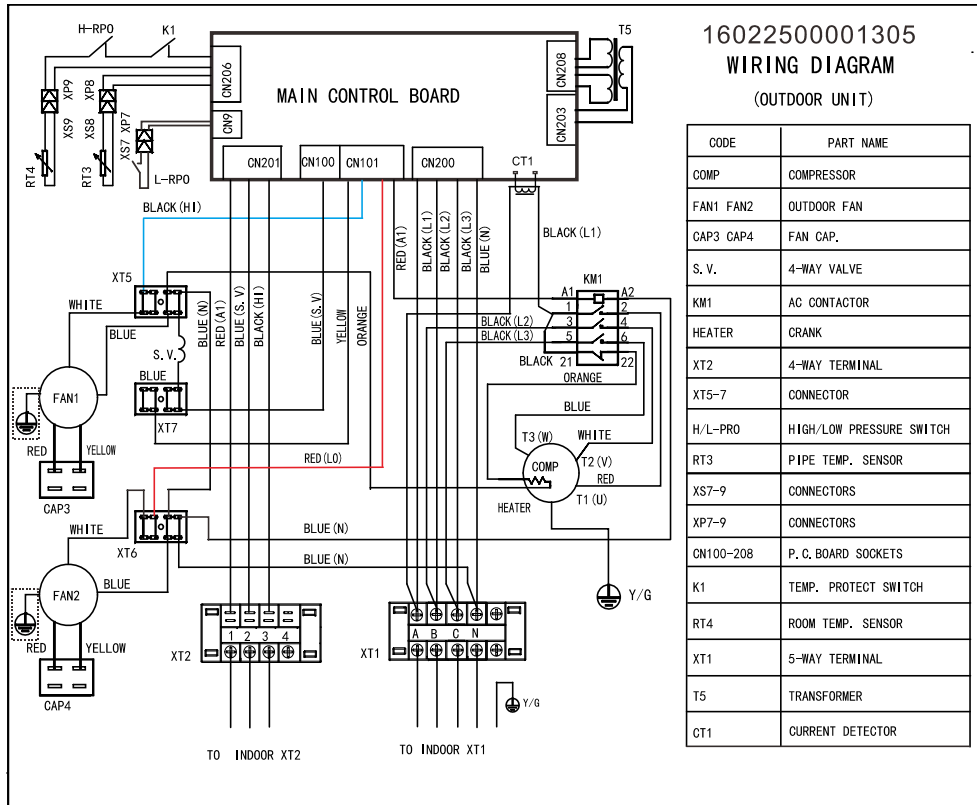

6. Electric Characteristics

Model	Outdoor Unit			
	Hz	Voltage	Min.	Max.
MOBA30U-12HN1-Q	50	220~240V	198V	254V
MOBA30U-18HN1-Q	50	220~240V	198V	254V
MOCA30U-24HN1-Q	50	220~240V	198V	254V
MOD31U-36HN1-R	50	380~415V	342V	436V
MOU-48HN1-R	50	380~415V	342V	436V
MOUA-60HN1-R	50	380~415V	342V	436V

7. Operation Limits

Mode \ Temperature	Cooling operation	Heating operation
Room temperature	17°C ~ 32°C	0°C ~ 30°C
Outdoor temperature	18°C ~ 43°C	-7°C ~ 24°C

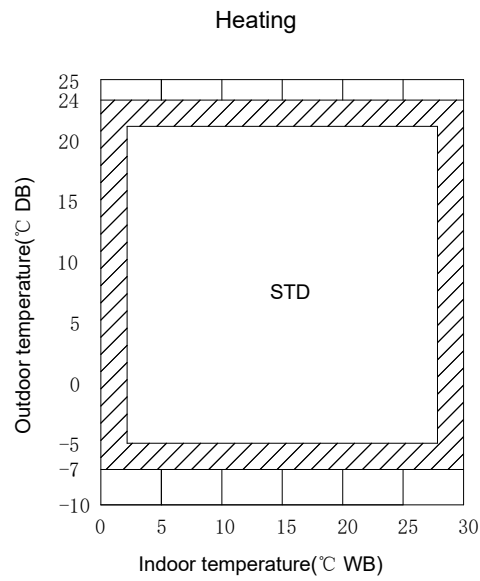
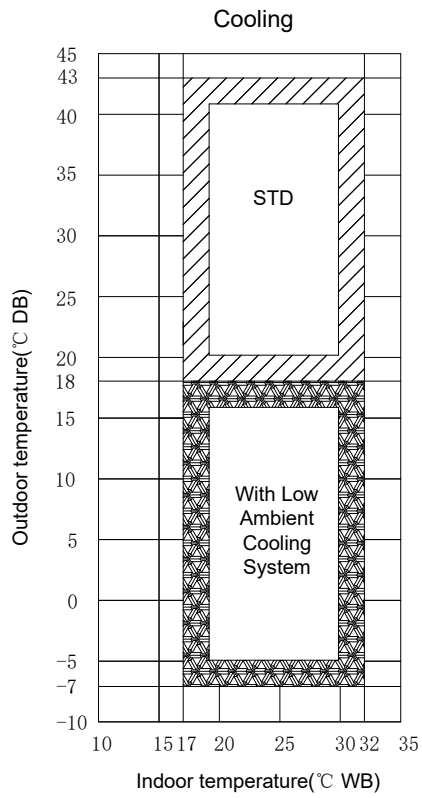

8. Sound Levels

Outdoor Unit

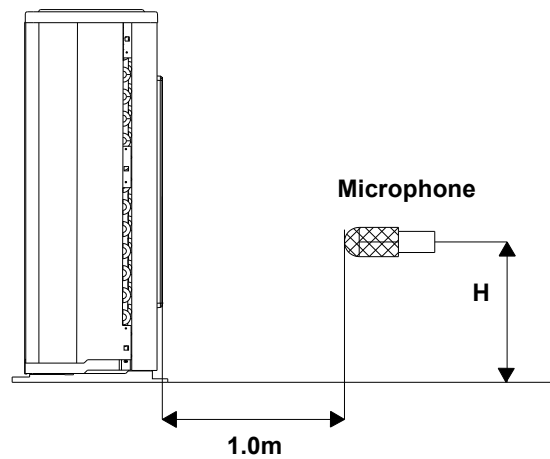

Note: $H = 0.5 \times$ height of outdoor unit

Model	Noise level dB(A)
MOBA30U-12HN1-Q	59
MOBA30U-18HN1-Q	62
MOCA30U-24HN1-Q	62
MOD31U-36HN1-R	64
MOU-48HN1-R	63
MOUA-60HN1-R	63

Part 4

Installation

1. Installation Procedure.....	131
2. Location selection	132
3. Indoor unit installation.....	133
4. Outdoor unit installation.....	155
5. Refrigerant pipe installation	156
6. Drainage pipe installation.....	158
7. Vacuum Drying and Leakage Checking	162
8. Additional refrigerant charge	163
9. Engineering of insulation	164
10. Engineering of electrical wiring	166
11. Test operation	167

1. Installation Procedure

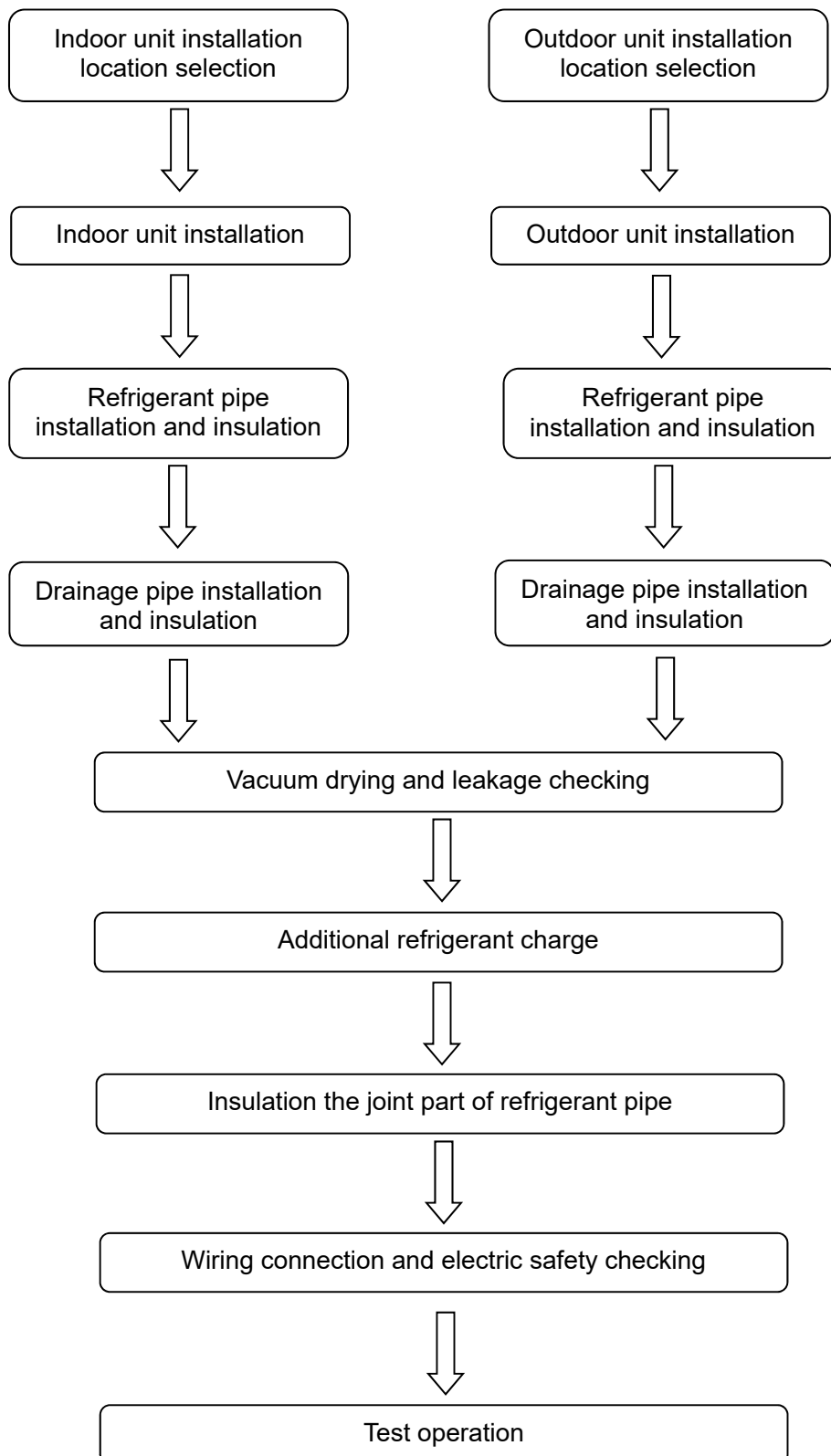

2. Location selection

2.1 Indoor unit location selection

- The place shall easily support the indoor unit's weight.
- The place can ensure the indoor unit installation and inspection.
- The place can ensure the indoor unit horizontally installed.
- The place shall allow easy water drainage.
- The place shall easily connect with the outdoor unit.
- The place where air circulation in the room should be good.
- There should not be any heat source or steam near the unit.
- There should not be any oil gas near the unit
- There should not be any corrosive gas near the unit
- There should not be any salty air near the unit
- There should not be strong electromagnetic wave near the unit
- There should not be inflammable materials or gas near the unit
- There should not be strong voltage vibration.

2.2 Outdoor unit location selection

- The place shall easily support the outdoor unit's weight.
- Locate the outdoor unit as close to indoor unit as possible
- The piping length and height drop can not exceed the allowable value.
- The place where the noise, vibration and outlet air do not disturb the neighbors.
- There is enough room for installation and maintenance.
- The air outlet and the air inlet are not impeded, and not face the strong wind.
- It is easy to install the connecting pipes and cables.
- There is no danger of fire due to leakage of inflammable gas.
- It should be a dry and well ventilation place
- The support should be flat and horizontal
- Do not install the outdoor unit in a dirty or severely polluted place, so as to avoid blockage of the heat exchanger in the outdoor unit.
- If is built over the unit to prevent direct sunlight, rain exposure, direct strong wind, snow and other scraps accumulation, make sure that heat radiation from the condenser is not restricted.

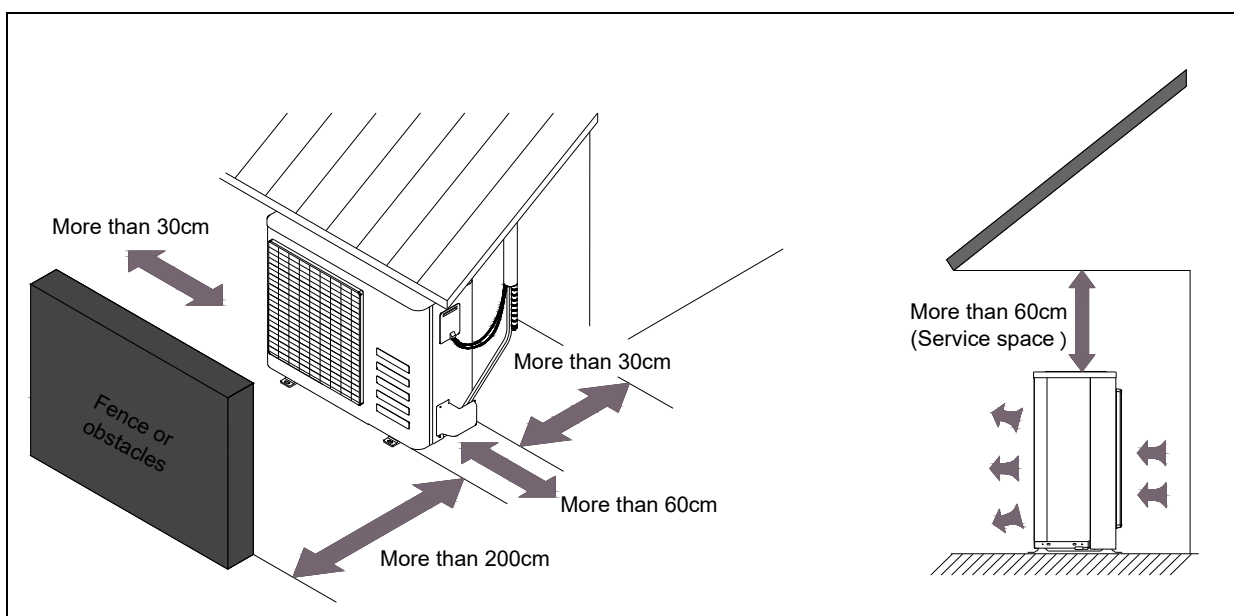

3. Indoor unit installation

3.1 Compact cassette indoor unit installation

3.1.1 Service space for indoor unit

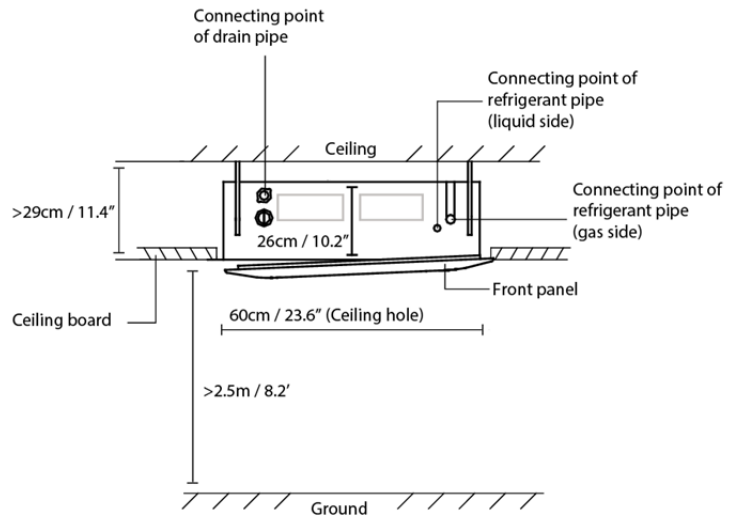
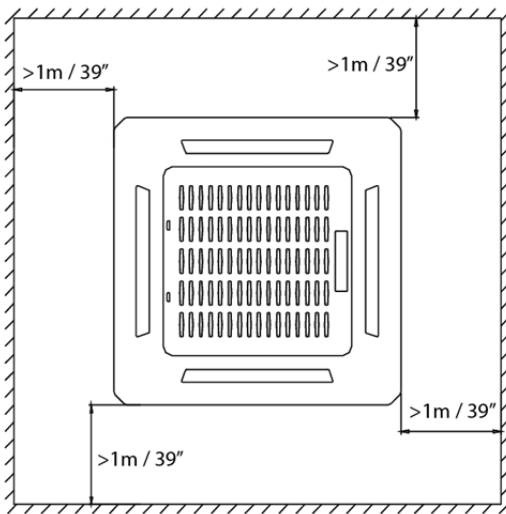

3.1.2 Bolt pitch

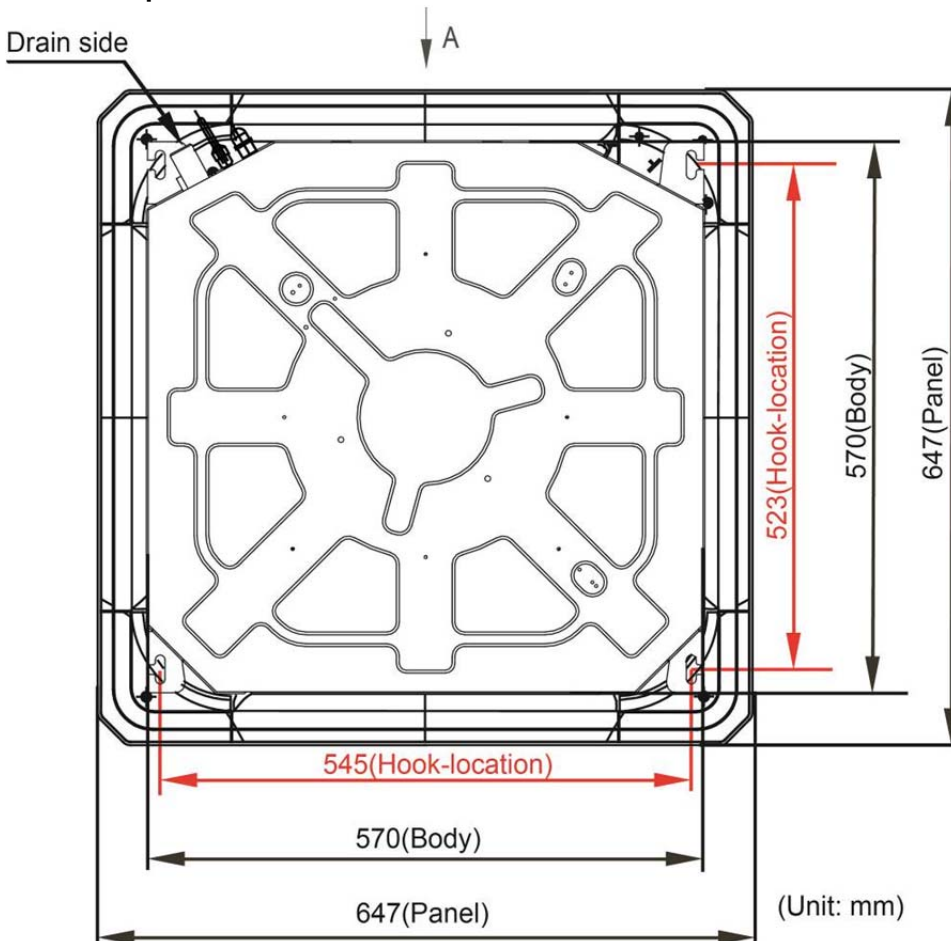

3.1.3 Install the pendant bolt

Select the position of installation hooks according to the hook holes positions showed in upper picture. Drill four holes of $\text{Ø}12\text{mm}$, 45~50mm deep at the selected positions on the ceiling. Then embed the expansible hooks (fittings).



Face the concave side of the installation hooks toward the expansible hooks. Determine the length of the installation hooks from the height of ceiling, then cut off the unnecessary part.

If the ceiling is extremely high, please determine the length of the installation hook depending on the real situation.

3.1.4 Install the main body

Make the 4 suspender through the 4 hanger of the main body to suspend it. Adjust the hexangular nuts on the four installation hooks evenly, to ensure the balance of the body. Use a leveling instrument to make sure the levelness of the main body is within $\pm 1^\circ$.

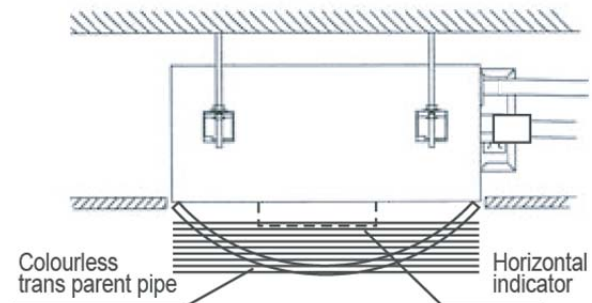

Adjust the position to ensure the gaps between the body and the four sides of ceiling are even. The body's lower part should sink into the ceiling for 10~12 mm. In general, L is half of the screw length of the installation hook.

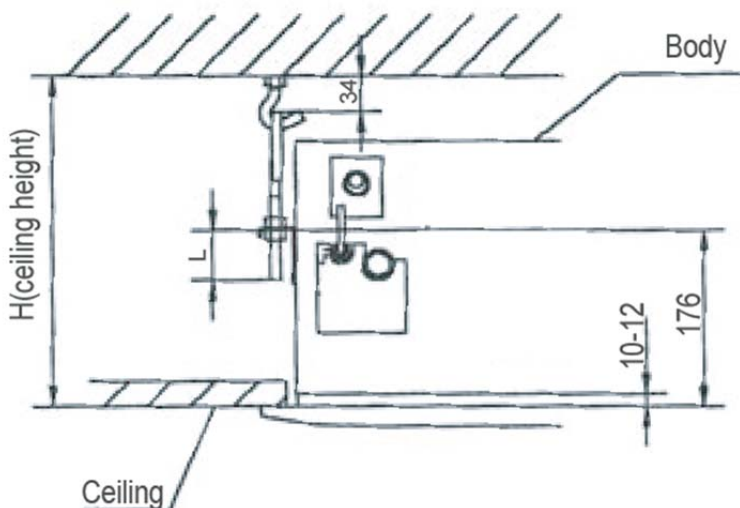

Locate the air conditioner firmly by wrenching the nuts after having adjusted the body's position well.

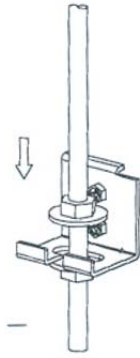

3.1.5 Install the panel

Remove the grille

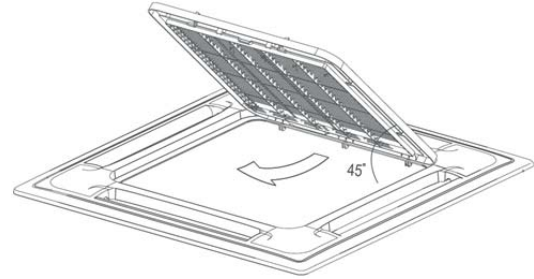
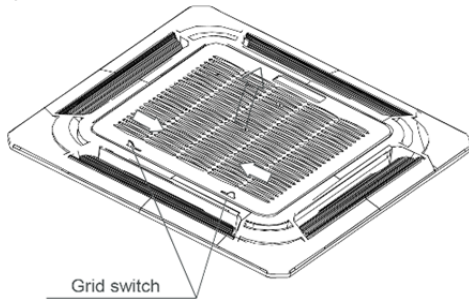

Hang the panel to the hooks on the mainbody.

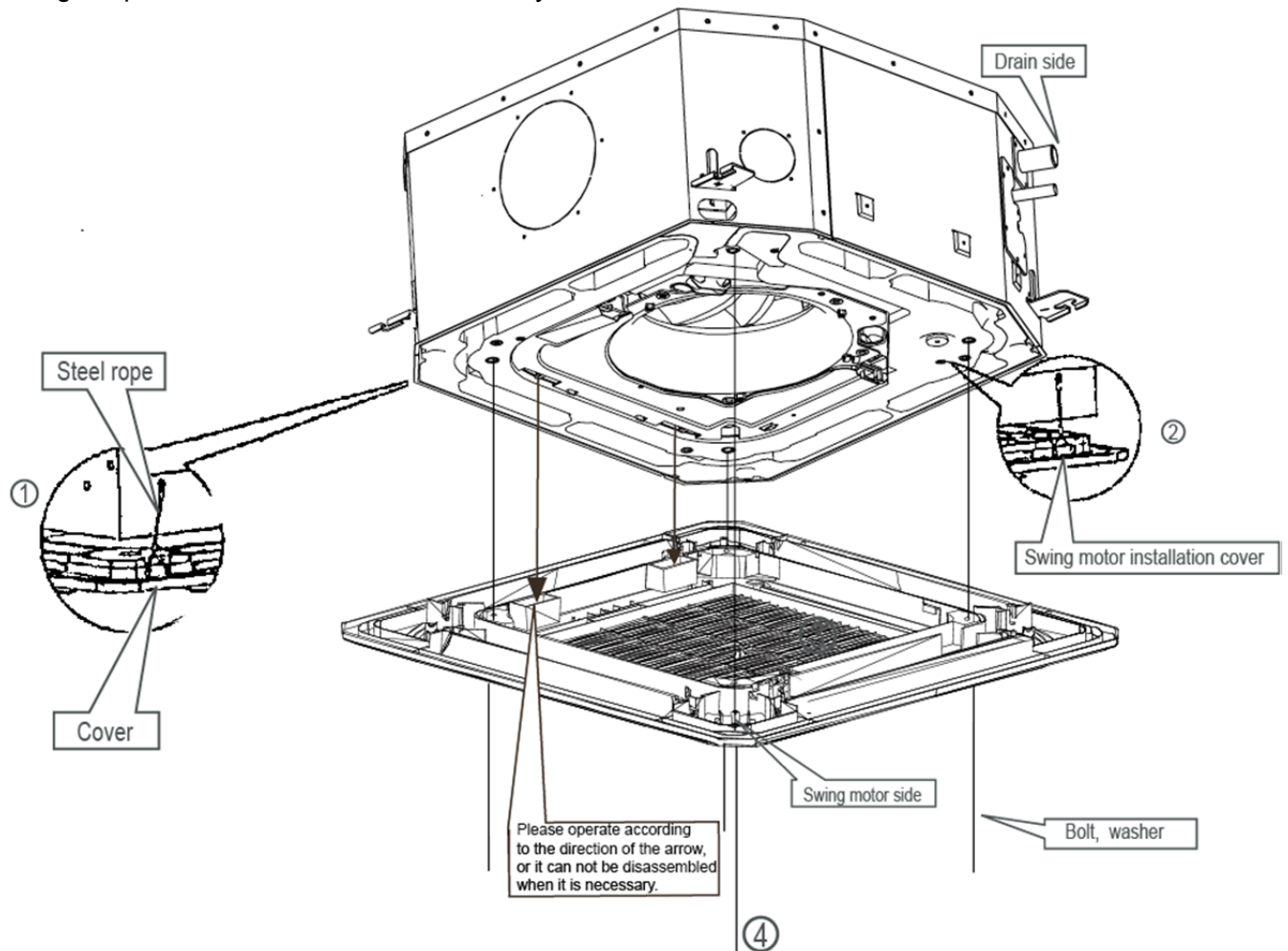

Tighten the screws under the panel hooks till the panel closely stick on the ceiling to avoid condensate water.

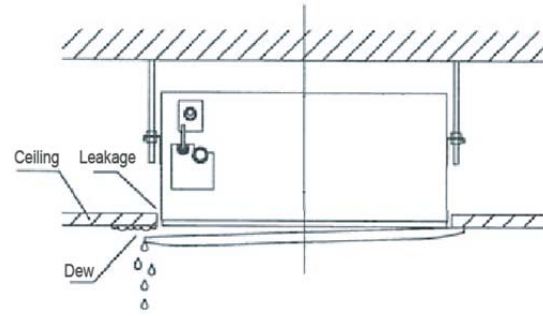
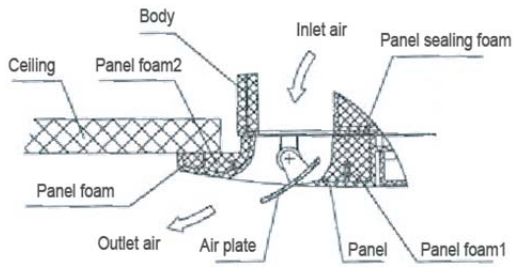

Hang the air-in grill to the panel, then connect the lead terminator of the swing motor and that of the control box with corresponding terminators on the body respectively.

Note: The panel shall be installed after the wiring connected.

3.2 Super-slim cassette indoor unit installation

3.2.1 Service space for indoor unit

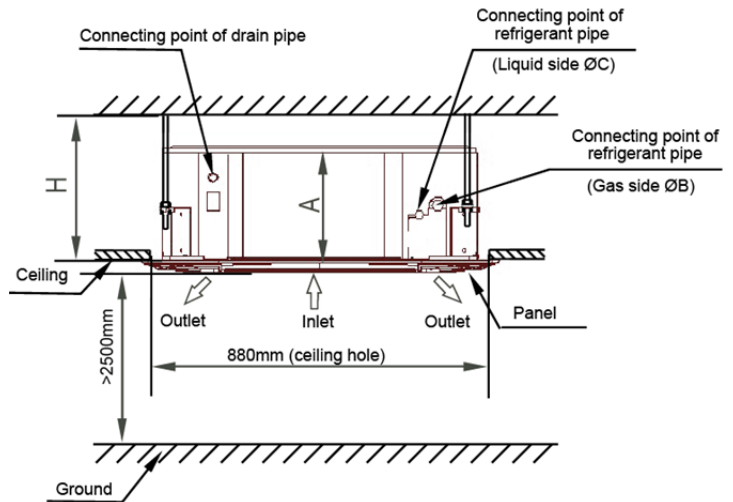
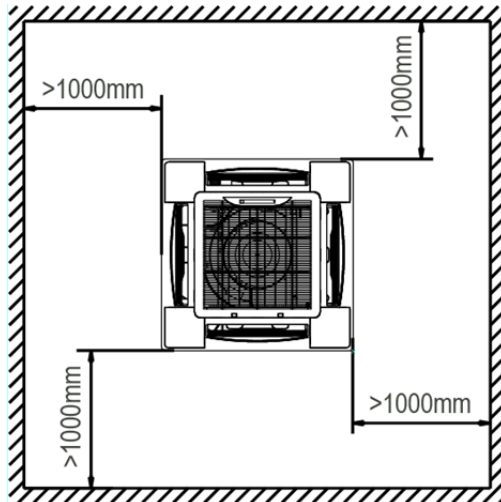

Model	A	H	Remark
18/24	205	>235	Cooling / Cooling & Heating
36/48	245	>275	Cooling / Cooling & Heating
60	287	>317	Cooling / Cooling & Heating

3.2.2 Bolt pitch

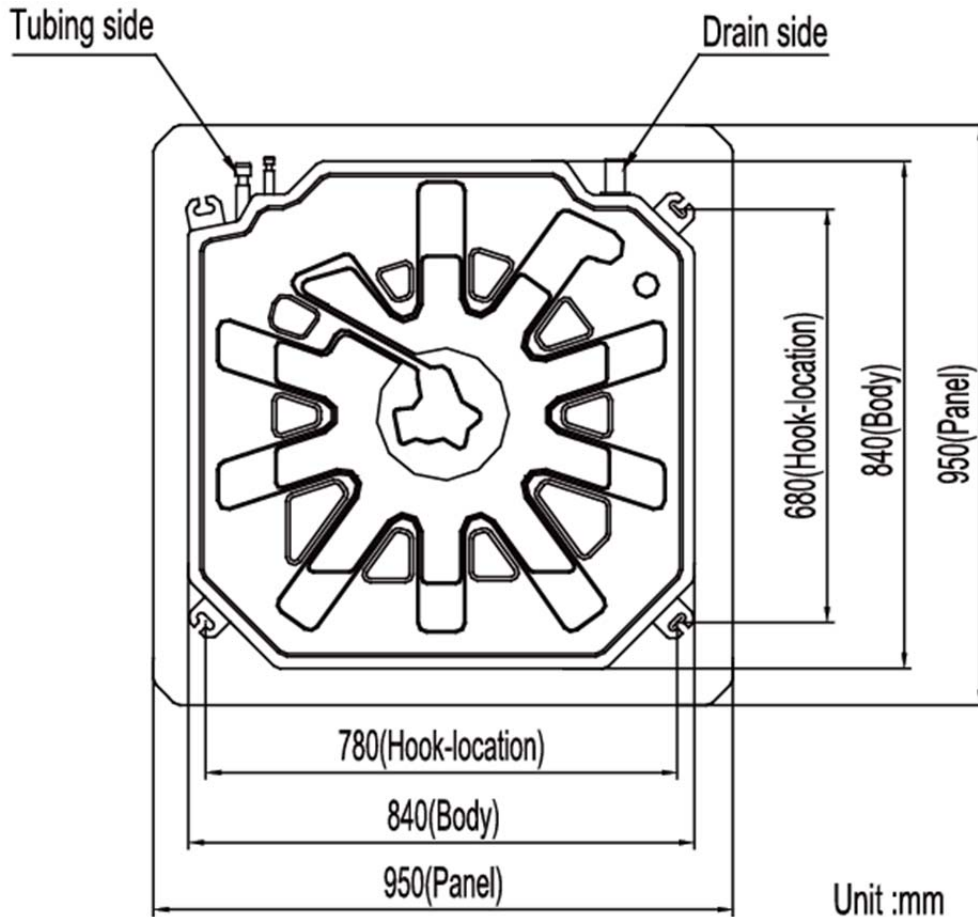

3.2.3 Install the pendant bolt

Select the position of installation hooks according to the hook holes positions showed in upper picture. Drill four holes of $\text{Ø}12\text{mm}$, 45~50mm deep at the selected positions on the ceiling. Then embed the expansible hooks (fittings).



3.2.4 Install the main body

Make the 4 suspender through the 4 hanger of the main body to suspend it. Adjust the hexangular nuts on the four installation hooks evenly, to ensure the balance of the body. Use a leveling instrument to make sure the levelness of the main body is within $\pm 1^\circ$.



Adjust the position to ensure the gaps between the body and the four sides of ceiling are even. The body's lower part should sink into the ceiling for 10~12 mm. In general, L is half of the screw length of the installation hook.

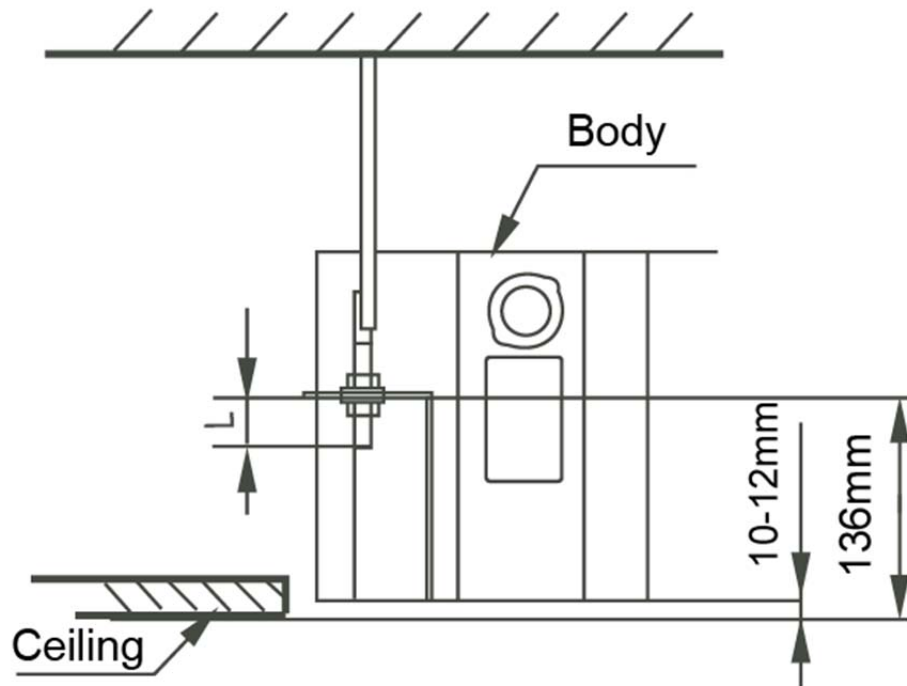

Locate the air conditioner firmly by wrenching the nuts after having adjusted the body's position well.

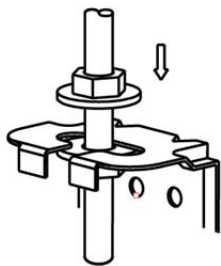

3.2.5 Install the panel

Remove the grille

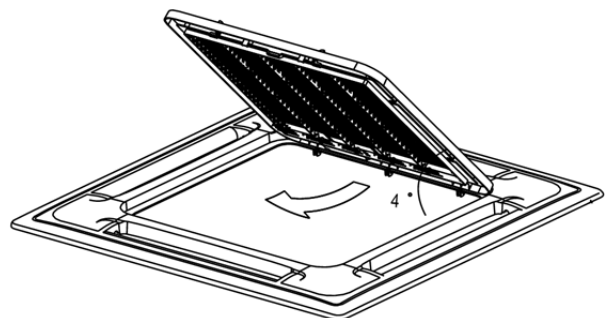
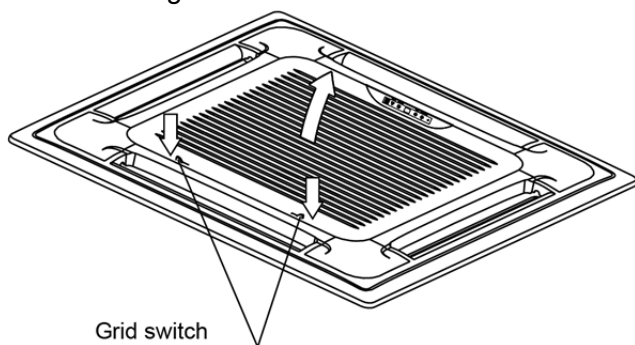

Remove the 4 corner covers.

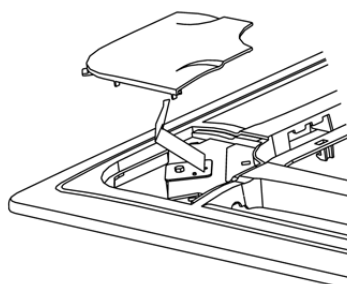

Hang the panel to the hooks on the mainbody. If the panel is with auto-lift grille, please watch the ropes lifing the grille, DO NOT make the ropes enwinded or blocked.

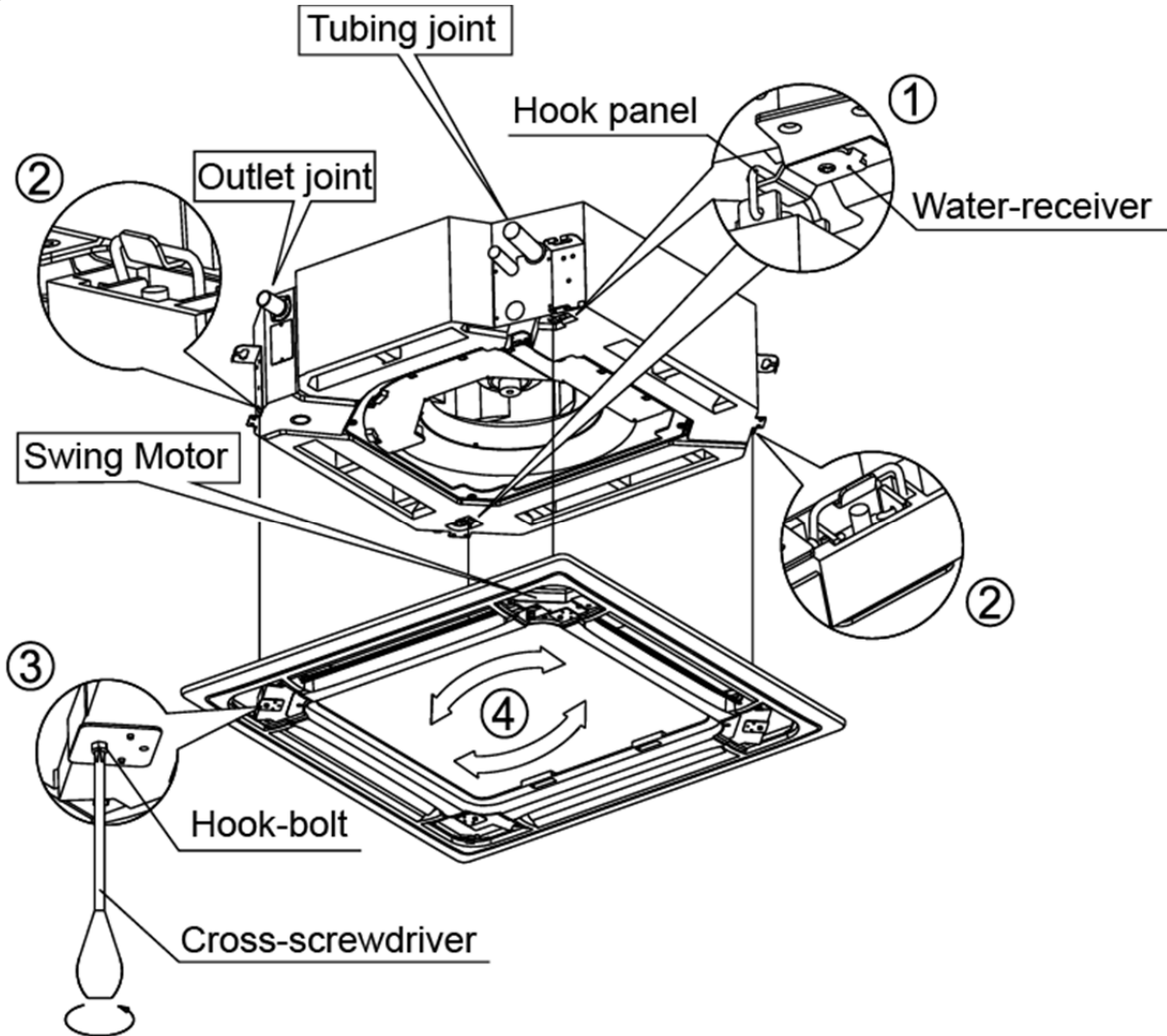

Tighten the screws under the panel hooks till the panel closely stick on the ceiling to avoid condensate water.

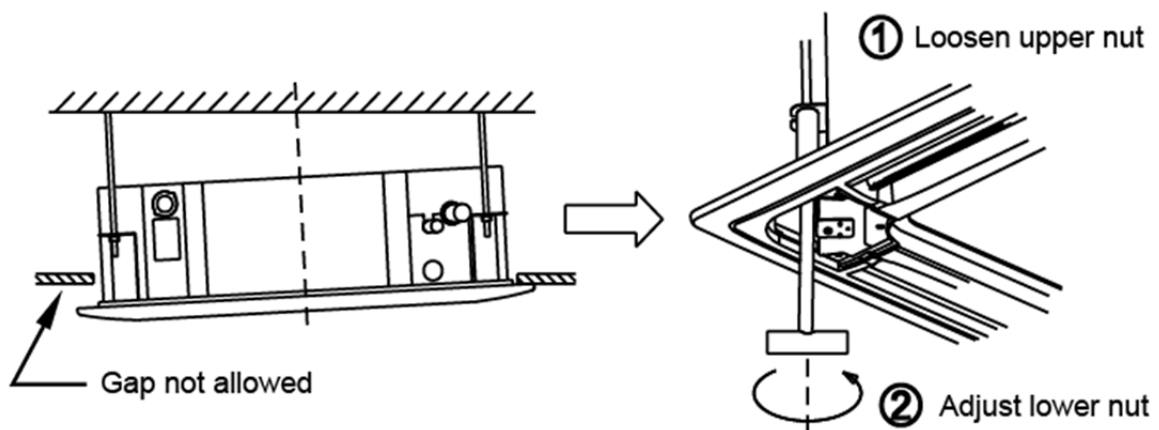

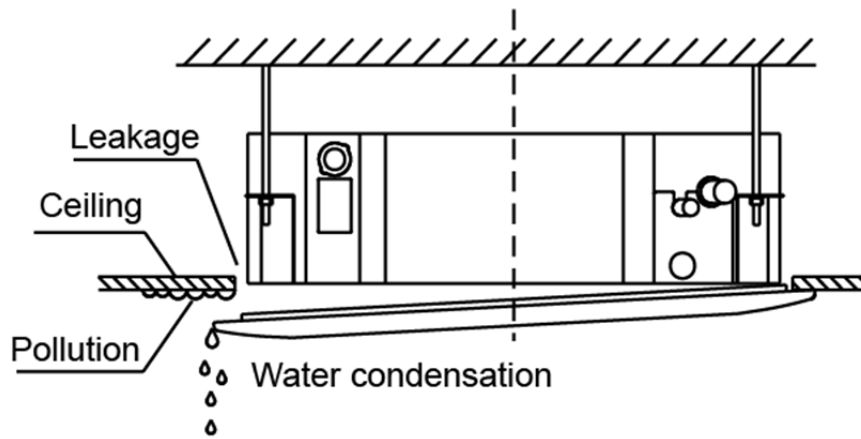

Hang the air-in grill to the panel, then connect the lead terminator of the swing motor and that of the control box with corresponding terminators on the body respectively.

Install the 4 corner covers back.

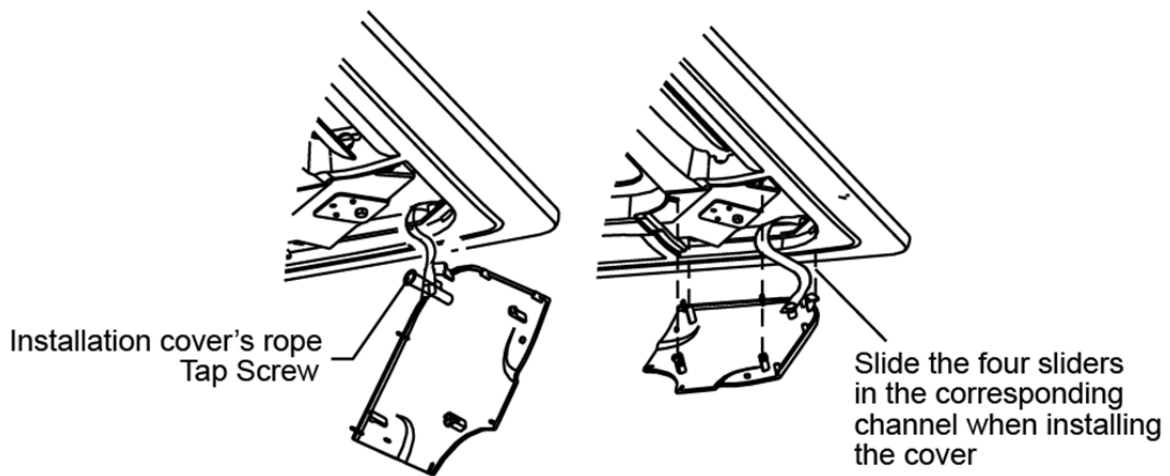

Note: The panel shall be installed after the wiring connected.

3.3 MSP duct (MTB) indoor unit installation

3.3.1 Service space for indoor unit

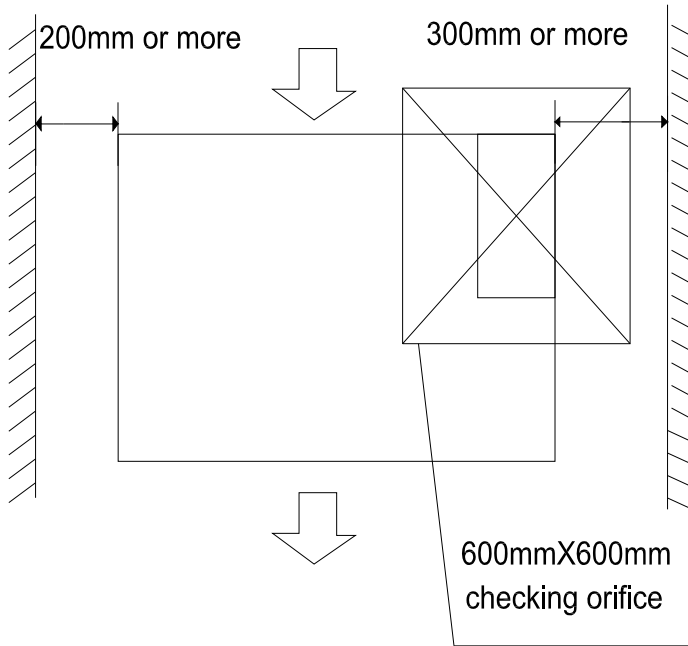

3.3.2 Bolt pitch

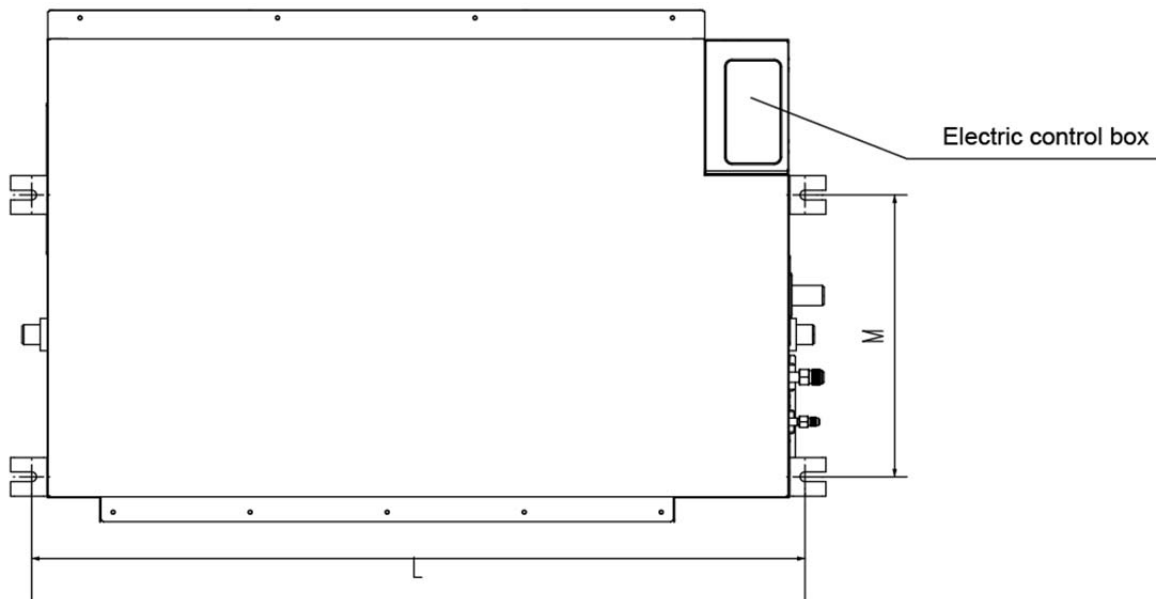

Capacity (KBtu)	Size of outline dimension mounted plug	
	L	M
9/12	740	350
18	960	350
24	960	350
36	1180	490
48/60	1240	500

3.3.3 Install the pendant bolt

Select the position of installation hooks according to the hook holes positions showed in upper picture. Drill four holes of $\text{Ø}12\text{mm}$, 45~50mm deep at the selected positions on the ceiling. Then embed the expansible hooks (fittings).



3.3.4 Install the main body

Make the 4 suspender through the 4 hanger of the main body to suspend it. Adjust the hexangular nuts on the four installation hooks evenly, to ensure the balance of the body. Use a leveling instrument to make sure the levelness of the main body is within $\pm 1^\circ$.

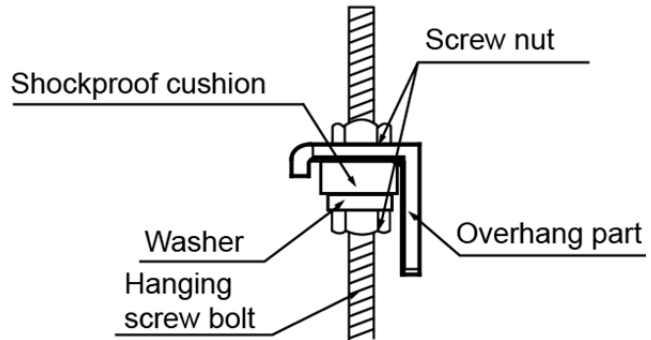

3.3.5 Install the air filter

Insert the air filter through the filter slot and fix it with 2 screws.

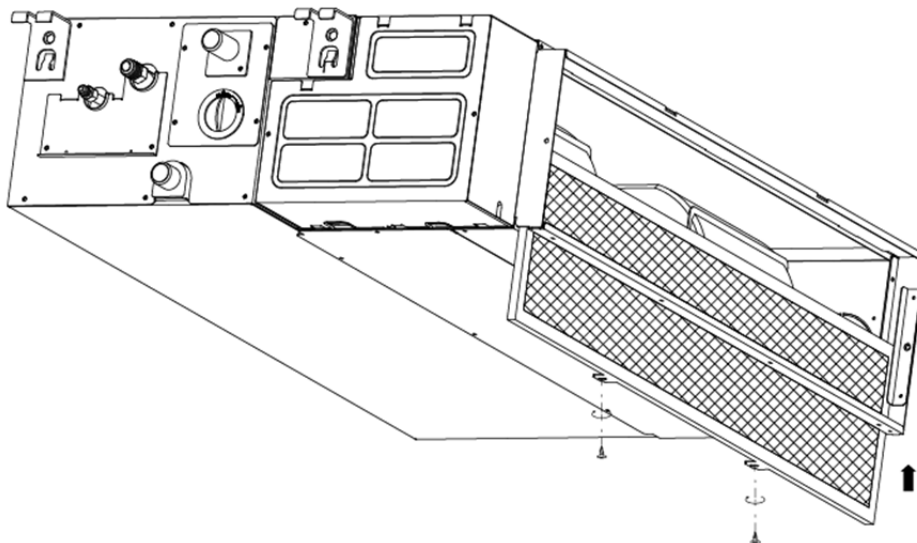

3.3.6 Install the air duct

Please design the air duct as below recommended picture

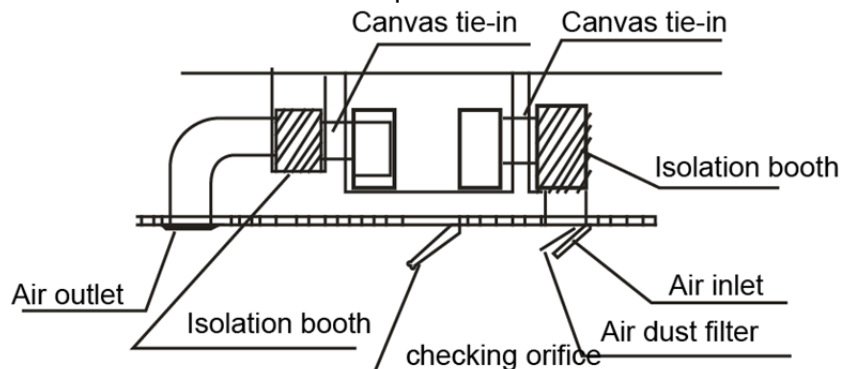

3.3.7 Change the air inlet direction

- ① Take off ventilation panel and flange, cut off the staples at side rail.

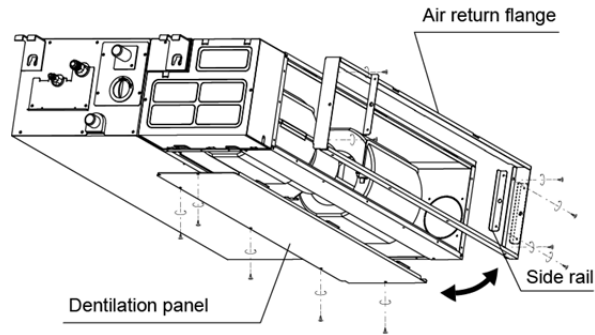

- ② Stick the attached seal sponge as per the indicating place in the following fig, and then change the mounting positions of air return panel and air return flange .

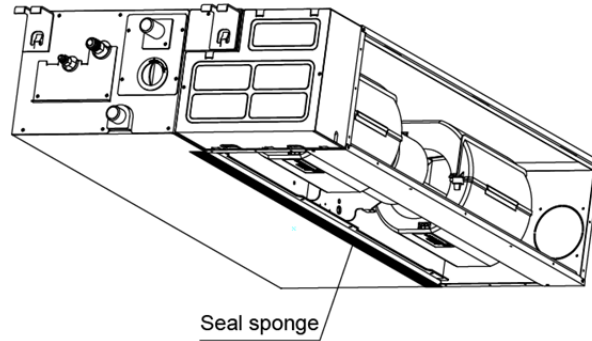

- ③ When install the filter mesh, please plug it into flange inclined from air return opening, and then push up.

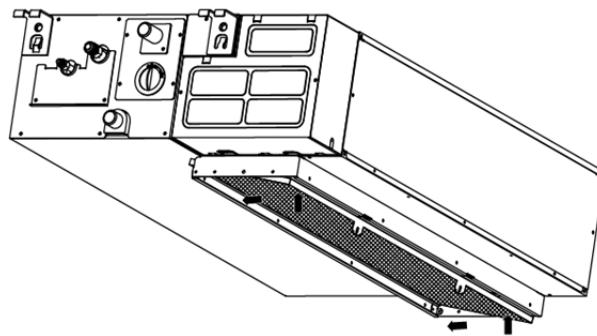

- ④ The installation has finish, upon filter mesh which fixing blocks have been insert to the flange positional holes.

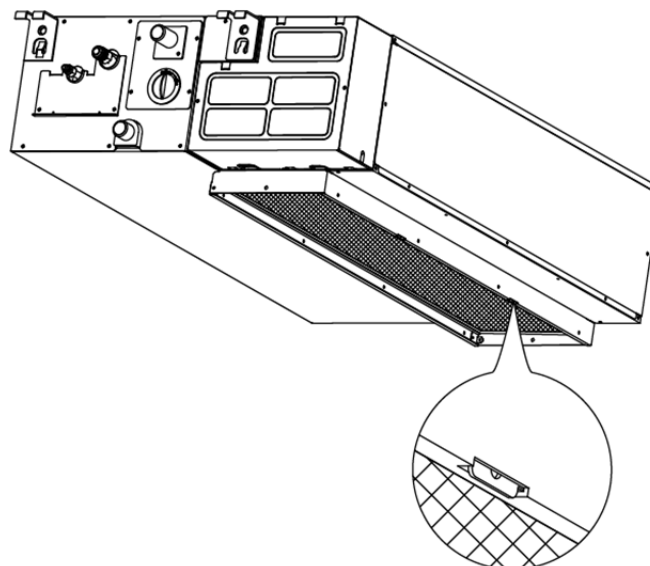

3.4 MSP duct (MTI) indoor unit installation

3.4.1 Service space for indoor unit

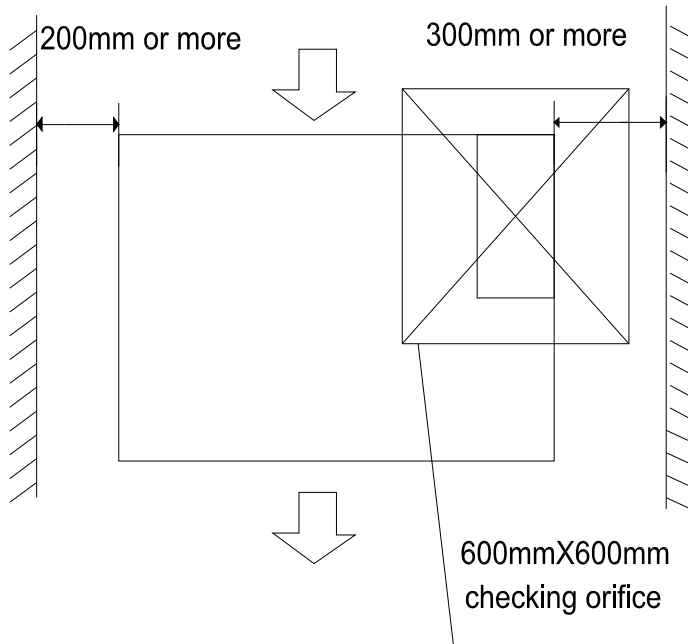

3.4.2 Bolt pitch

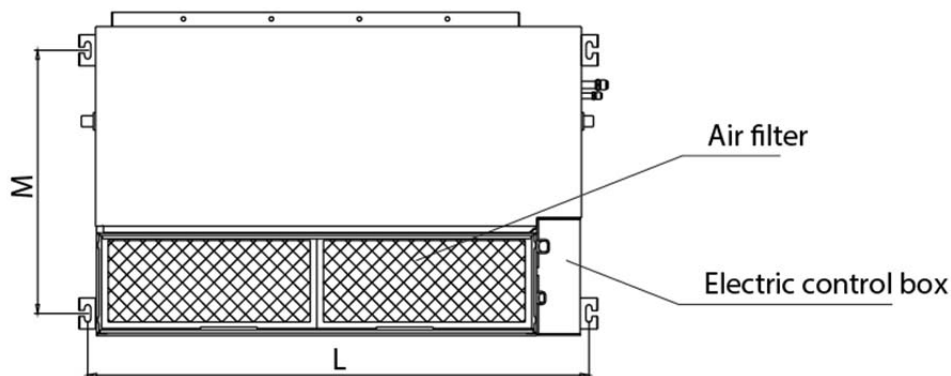

Capacity	Size of outline dimension mounted plug	
	L	M
18K	920	508
24K~36K	1140	598
48K~60K	1240	697

3.4.3 Hang indoor unit

1. Please refer to the upper data to locate the four positioning screw bolt hole on the ceiling. Be sure to mark the areas where ceiling hook holes will be drilled.
2. Carry out the pipe and line operation in the ceiling after finishing the installation of the main body. While choosing where to start the operation, determine the direction of the pipes to be drawn out. Especially in case there is a ceiling, position the refrigerant pipes, drain pipes, indoor & outdoor lines to the connection places before hanging up the machine.
3. The installation of hanging screw bolts.
 - Cut off the roof beam.
 - Strengthen the place that has been cut off, and consolidate the roof beam.
4. After the selection of installation location position the refrigerant pipes, drain pipes, indoor & outdoor wires to the connection places before hanging up the machine.

5. Drill 4 holes 10cm (4") deep at the ceiling hook positions in the internal ceiling. Be sure to hold the drill at a 90° angle to the ceiling.
- a 90° angle to the ceiling.
6. Secure the bolt using the included washers and nuts.
7. Install the four suspension bolts.
8. Mount the indoor unit. You will need two people to lift and secure it. Insert suspension bolts into the unit's hanging holes. Fasten them using the included washers and nuts

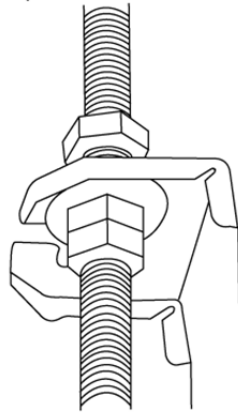

9. Overhang the indoor unit onto the hanging screw bolts with block. Position the indoor unit in a flat level by using the level indicator, unless it may cause leakage.

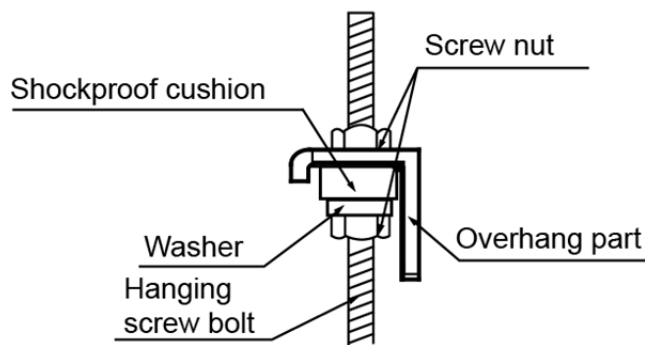

Note: Confirm the minimum drain tilt is 1/100 or more.

3.4.4 Duct and accessories installation

1. Install the filter(optional) according to air inlet size.
2. Install the canvas tie-in between the body and duct.
3. Air inlet and air outlet duct should be apart far enough to avoid air passage short-circuit.
4. Recommended duct connection.

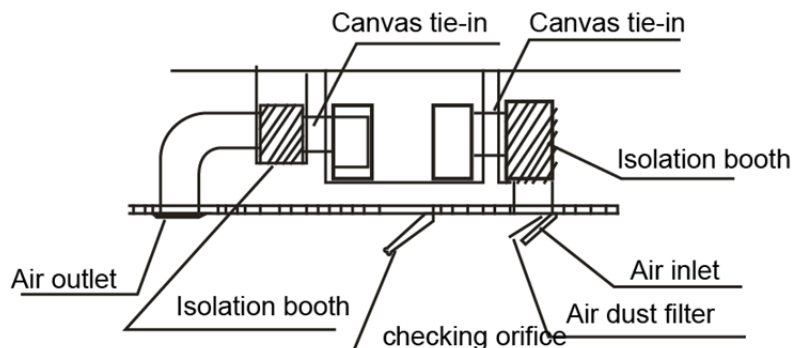

5. Please refer to the following static pressure to install..

Model(KBtu/h)	Static Pressure(Pa)
18~30	0~80
36	0~100
48~60	0~160

Change the fan motor static pressure corresponding to external duct static pressure.

NOTE: 1.Do not put the connecting duct weight on the indoor unit.

2.When connecting duct, use inflammable canvas tie-in to prevent vibrating.

3.Insulation foam should be wrapped outside the duct to avoid condensate and internal duct underlayer shall be added to reduce the noise for special requirement.

3.4.7 Adjust the air inlet direction(From rear side to under-side.)

① Take off ventilation panel and flange,

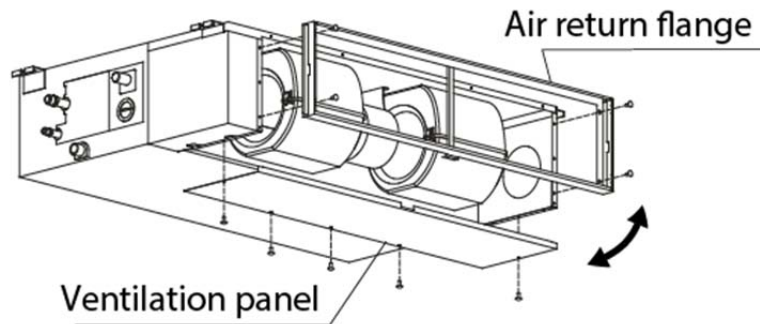

② Change the mounting positions of ventilation panel and air return flange .

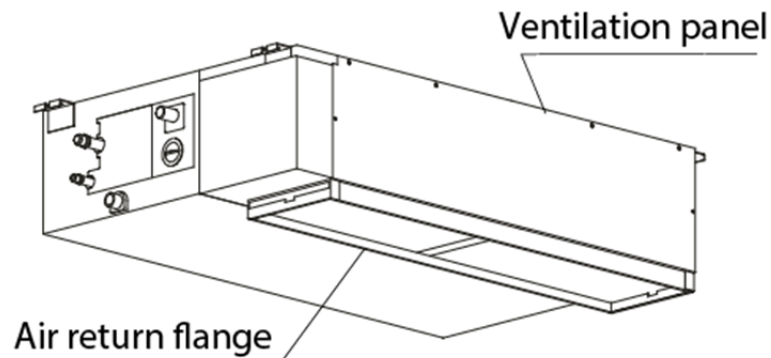

③ When install the filter mesh, please plug it into flange as shown in figure below.

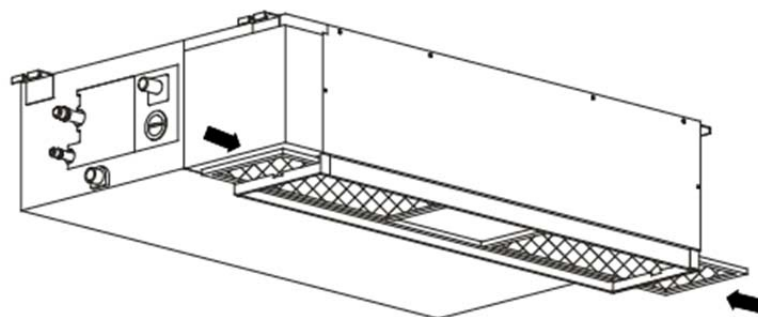

NOTE: All the figures in this manual are for explanation purpose only. They may be slightly different from the air conditioner you purchased.

The actual unit shall prevail.

3.5 HSP duct indoor unit installation

3.1 Service space for indoor unit

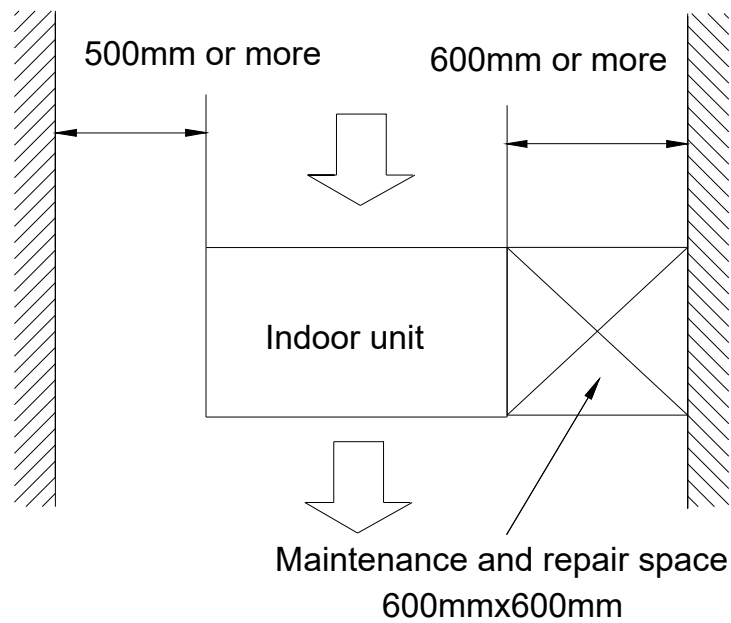

3.2 Bolt pitch

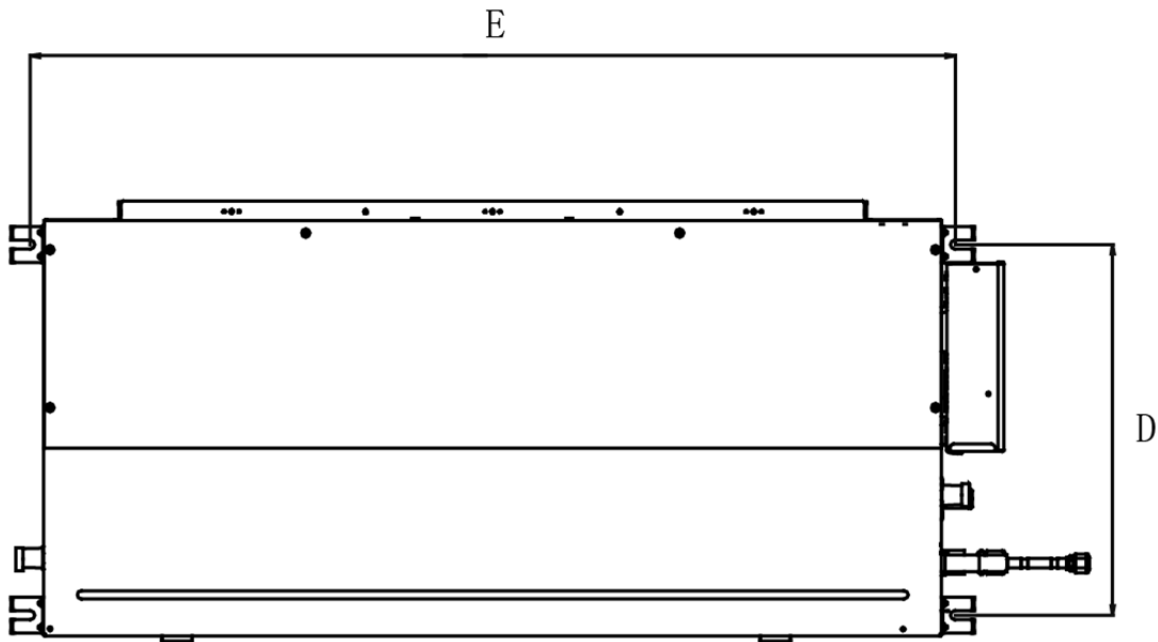

Capacity (KBtu)	Size of mounted lug	
	D	E
24	397	936
36	397	1146
48/60	495	1236

3.3 Install the pendant bolt

Select the position of installation hooks according to the hook holes positions showed in upper picture. Drill four holes of Ø12mm, 45~50mm deep at the selected positions on the ceiling. Then embed the expansible hooks (fittings).



3.4 Install the main body

Make the 4 suspender through the 4 hanger of the main body to suspend it. Adjust the hexangular nuts on the four installation hooks evenly, to ensure the balance of the body. Use a leveling instrument to make sure the levelness of the main body is within $\pm 1^\circ$.

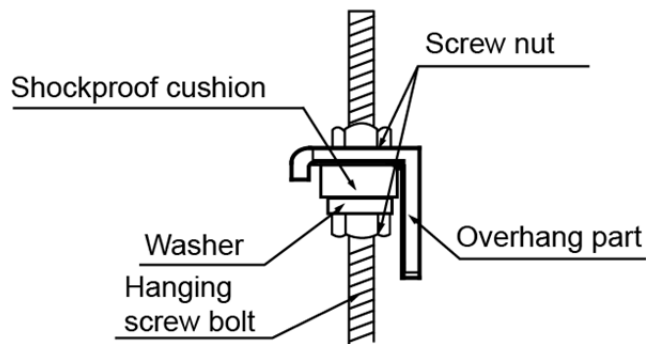

3.5 Install the air duct

Please design the air duct as below recommended picture

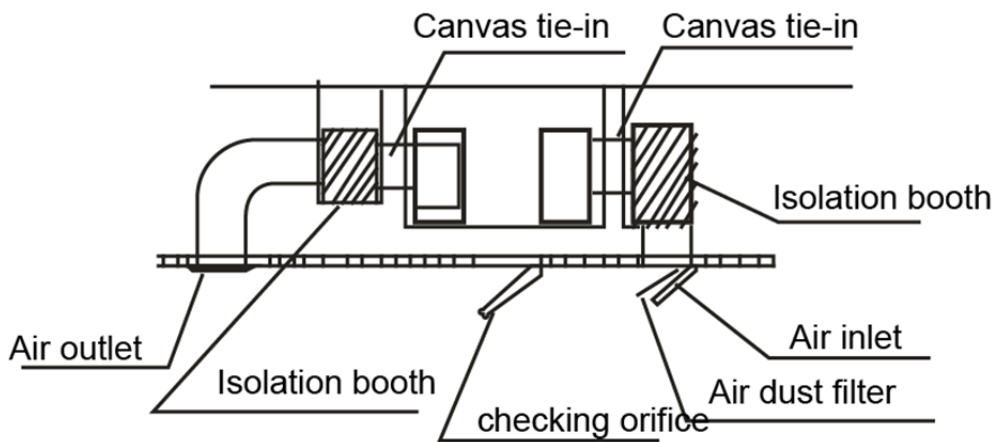

3.6 Ceiling & floor indoor unit installation

3.6.1 Service space for indoor unit

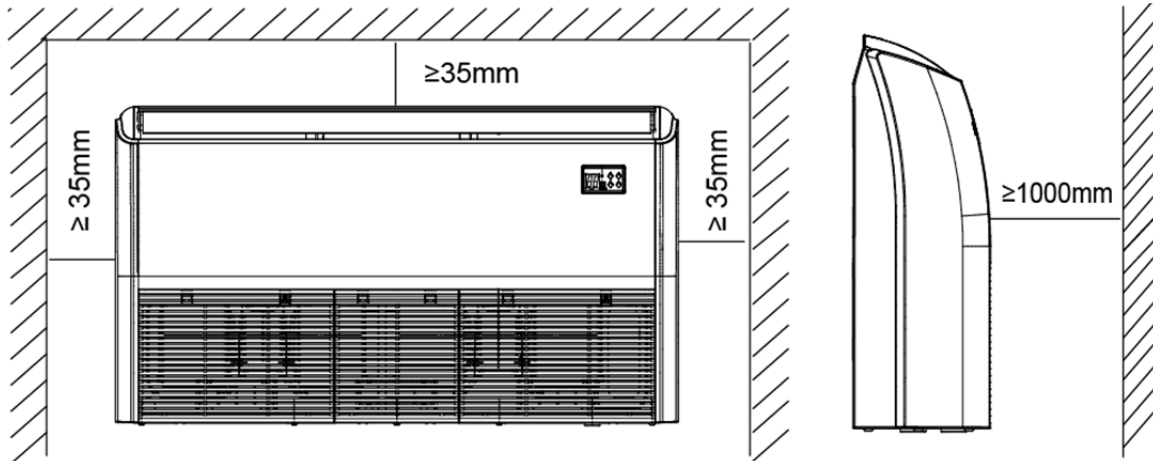

3.6.2 Bolt pitch

① Ceiling installation

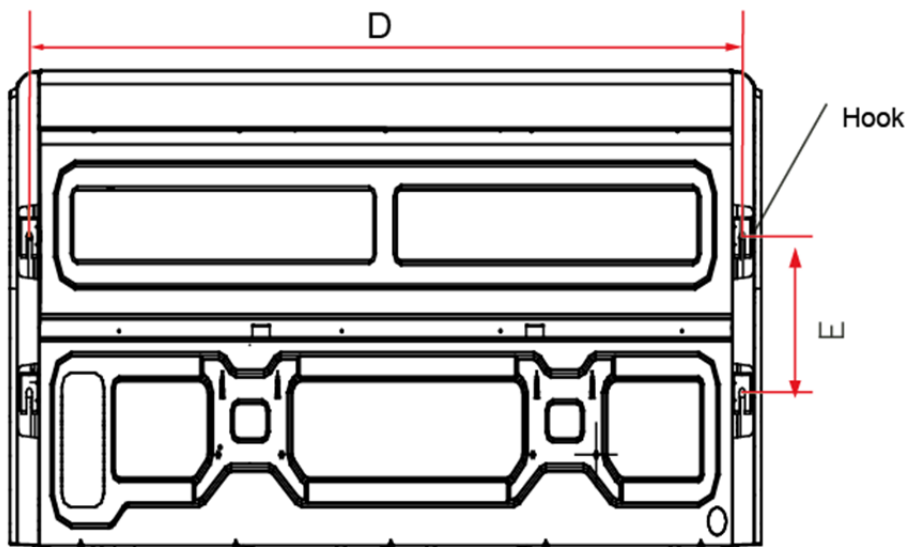

Capacity (Btu/h)	D	E
12-24K	983	220
30~36K	1200	220
48-60K	1565	220

② Wall-mounted installation

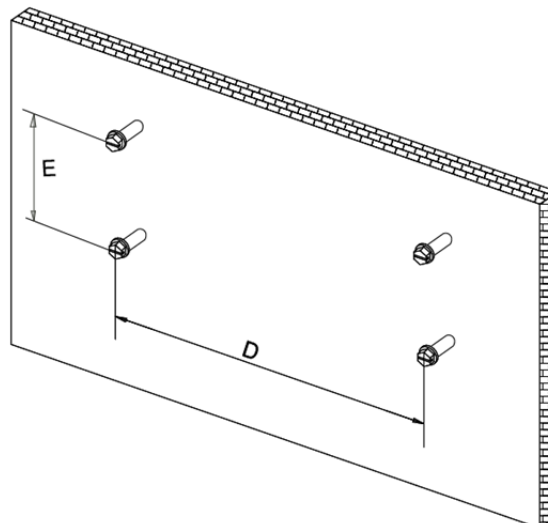

3.6.3 Install the pendant bolt

① Ceiling installation

Select the position of installation hooks according to the hook holes positions showed in upper picture. Drill four holes of $\varnothing 12\text{mm}$, 45~50mm deep at the selected positions on the ceiling. Then embed the expansible hooks (fittings).



② Wall-mounted installation

Install the tapping screws onto the wall.(Refer to picture below)

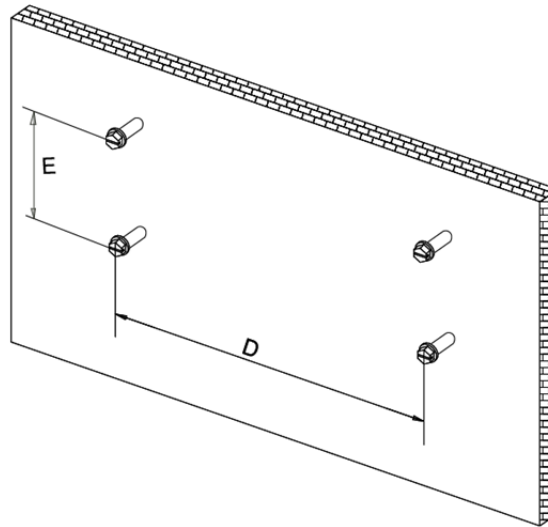

3.6.4 Install the main body

① Ceiling installation (The only installation method for the unit with drain pump)

Remove the side board and the grille.

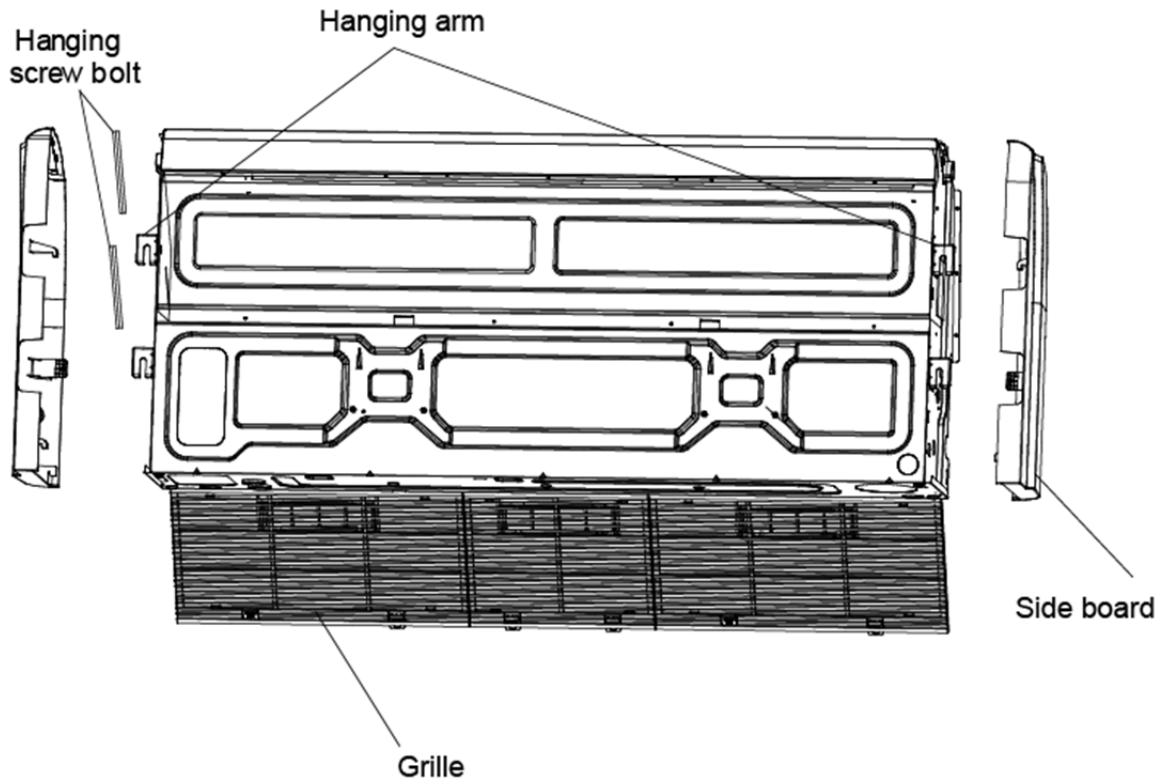

Locate the hanging arm on the hanging screw bolt. Prepare the mounting bolts on the unit.

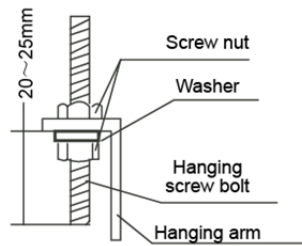

Put the side panels and grilles back.

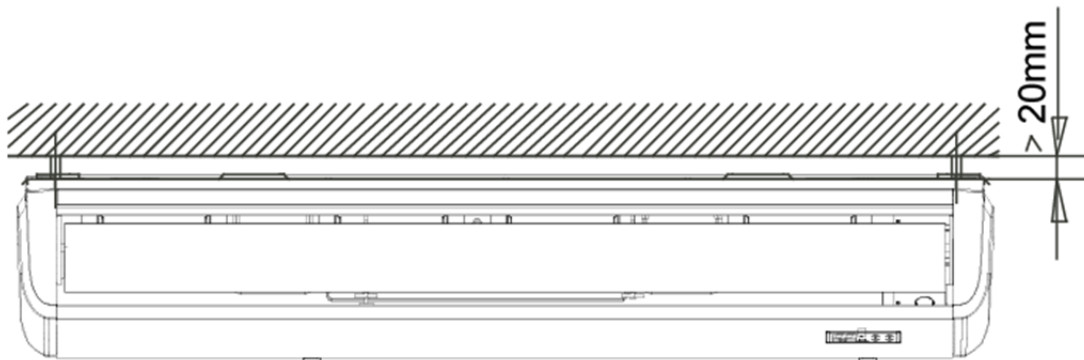

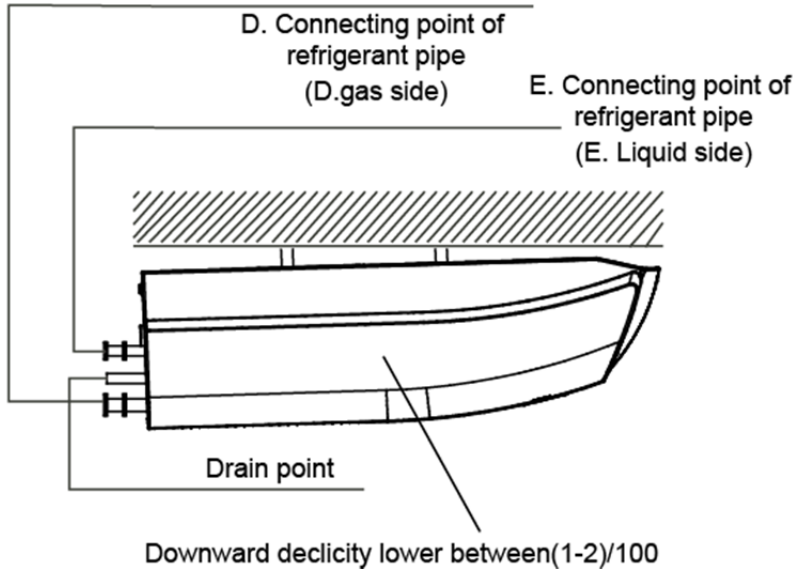

② Wall-mounted installation

Hang the indoor unit by insert the tapping screws into the hanging arms on the main unit. (The bottom of body can touch with floor or suspended, but the body must install vertically.)

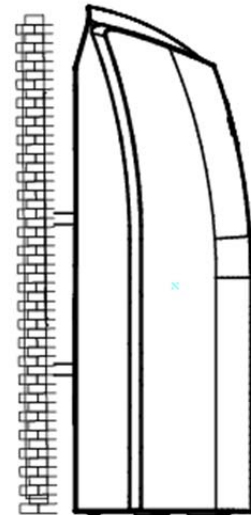
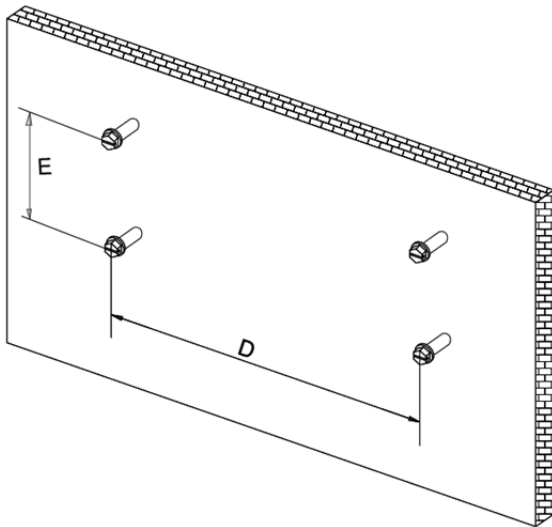

3.7 Floor standing indoor unit installation

3.7.1 Service space for indoor unit

- A place which provides the spaces around the indoor unit as required above in the diagram.
- A place where is no obstacle near the inlet and outlet area.
- A place which can bear the weight of the indoor unit.
- A place which allows the air filter to be removed downward.
- A place where the reception range is not exposed to direct sunlight.
- In the center of the room where possible.

3.8.1.1 Please stand the unit in hard and flat ground;

Please reserve space for installation and maintenance.

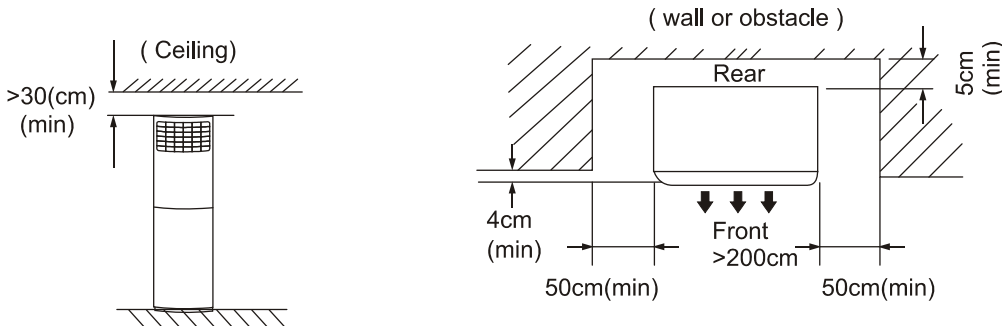

3.7.2 Installing

3.7.2.1. Anti-falling;

To prevent the indoor unit from falling, you must:

- Pay full attention to the unit because its long outer shape makes it easy to fall;
- Firmly fix the unit to the wall or in the ground to avoid accidental falling.

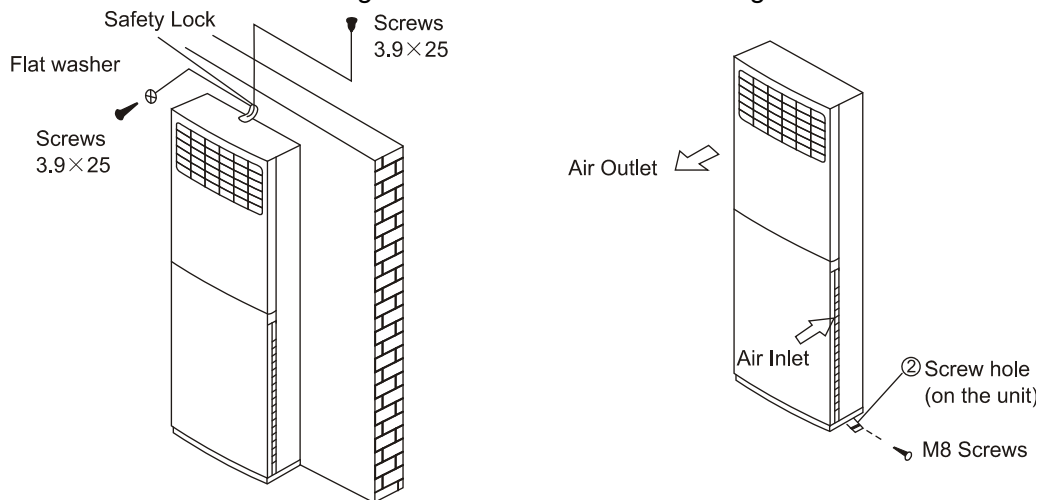

3.7.2.2. Dismounting the air-inlet grid

Please take off the air-inlet grid before connecting the pipes/wires.

The grid is hitched by a loop inside. To dismount the air-inlet grid, hold both sides of the grid and pull it up, let it slant downwards until the loop become straight. Then removing the screws fastened the loop with the grid, and the grid goes free.

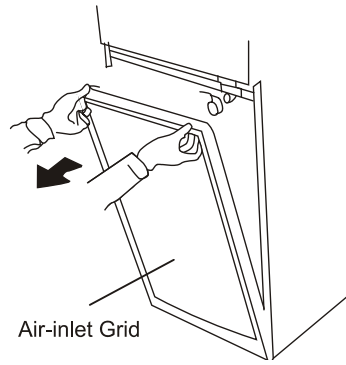

3.7.2.3. Take the Pipe Clip off before connecting the pipes and wiring; fit it when these finished.
Use accessories to connect the pipes/wires on both sides and back side.

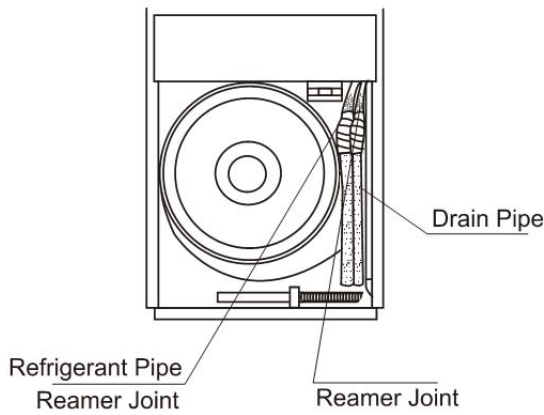

Pipe/wire-hole positions on both sides

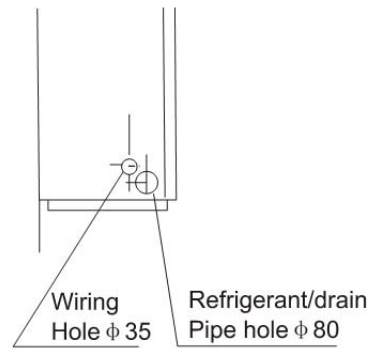

Pipe/wire-hole position on back side

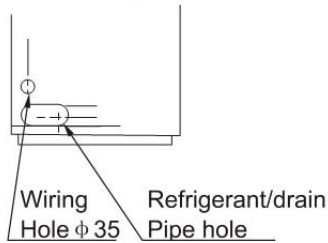

Pipe/wire-hole position on the bottom

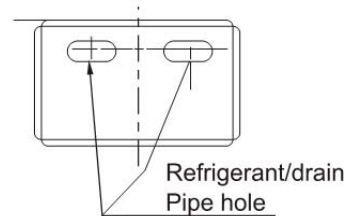

4. Outdoor unit installation

4.1 Service space for outdoor unit

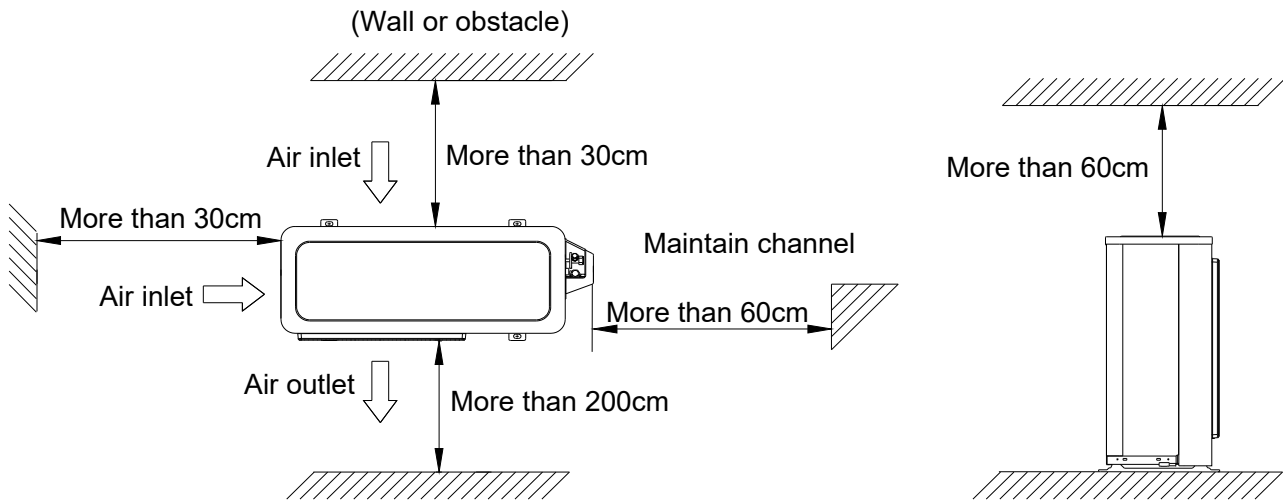

4.2 Bolt pitch

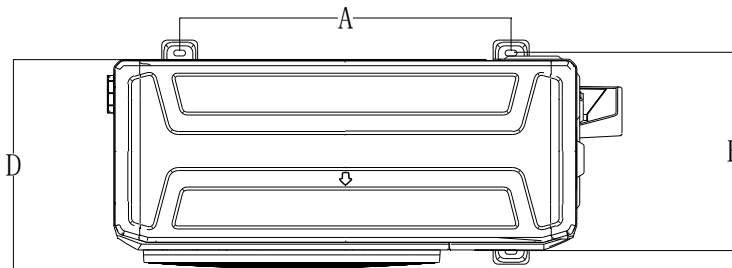

For the value of A,B and D, please refer to the dimension part.

4.3 Install the Unit

Since the gravity center of the unit is not at its physical center, so please be careful when lifting it with a sling.
 Never hold the inlet of the outdoor unit to prevent it from deforming.
 Do not touch the fan with hands or other objects.
 Do not lean it more than 45°, and do not lay it sidelong.
 Make concrete foundation according to the specifications of the outdoor units.
 Fasten the feet of this unit with bolts firmly to prevent it from collapsing in case of earthquake or strong wind.

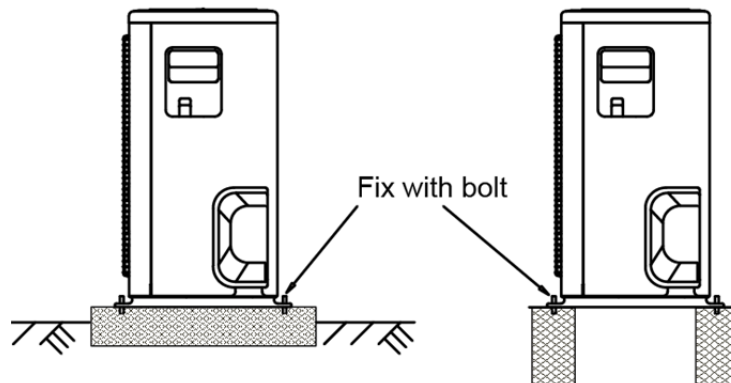

5. Refrigerant pipe installation

5.1 Maximum pipe length and height drop

Considering the allowable pipe length and height drop to decide the installation position. Make sure the distance and height drop between indoor and outdoor unit not exceeded the date in the following table.

Capacity	Max. Length	Max. Elevation
12,000Btu/h	15m	8m
18,000Btu/h~24,000Btu/h	25m	15m
36,000Btu/h	30m	20m
48,000Btu/h~60,000Btu/h	50m	30m

5.2 The procedure of connecting pipes

5.2.1 Choose the pipe size according to the specification table.

5.2.2 Confirm the cross way of the pipes.

5.2.3 Measure the necessary pipe length.

5.2.4 Cut the selected pipe with pipe cutter

- Make the section flat and smooth.

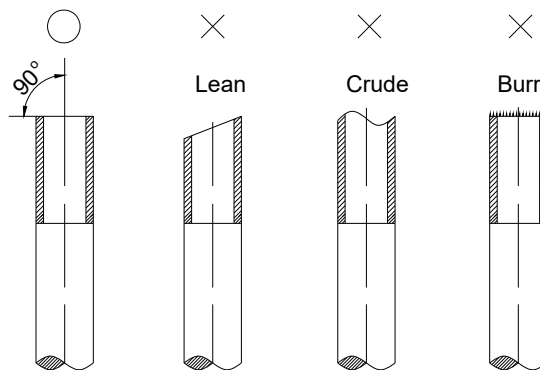

5.2.5 Insulate the copper pipe

- Before test operation, the joint parts should not be heat insulated.

5.2.6 Flare the pipe

- Insert a flare nut into the pipe before flaring the pipe
- According to the following table to flare the pipe

Pipe diameter	Flare dimension A (mm)		Flare shape
	Min	Max	
1/4" (6.35)	8.3	8.7	
3/8" (9.52)	12.0	12.4	
1/2" (12.7)	15.4	15.8	
5/8" (15.9)	18.6	19.1	
3/4" (19)	22.9	23.3	

- After flared the pipe, the opening part must be seal by end cover or adhesive tape to avoid duct or exogenous impurity come into the pipe.

5.2.7 Drill holes if the pipes need to pass the wall.

5.2.8 According to the field condition to bend the pipes so that it can pass the wall smoothly.

5.2.9 Bind and wrap the wire together with the insulated pipe if necessary.

5.2.10 Set the wall conduit

5.2.11 Set the supporter for the pipe.**5.2.12 Locate the pipe and fix it by supporter**

- For horizontal refrigerant pipe, the distance between supporters should not be exceed 1m.
- For vertical refrigerant pipe, the distance between supporters should not be exceed 1.5m.

5.2.13 Connect the pipe to indoor unit and outdoor unit by using two spanners.

- Be sure to use two spanners and proper torque to fasten the nut, too large torque will damage the bellmouthing, and too small torque may cause leakage. Refer the following table for different pipe connection.

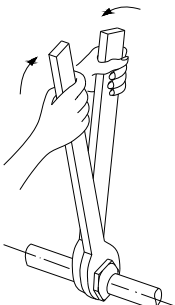
Pipe Diameter	Torque		Sketch map
	(kgf.cm)	(N.cm)	
1/4" (6.35)	144~176	1420~1720	
3/8" (9.52)	333~407	3270~3990	
1/2" (12.7)	504~616	4950~6030	
5/8" (15.9)	630~770	6180~7540	
3/4" (19)	990~1210	9270~11860	

6. Drainage pipe installation

Install the drainage pipe as shown below and take measures against condensation. Improperly installation could lead to leakage and eventually wet furniture and belongings.

6.1 Installation principle

- Ensure at least 1/100 slope of the drainage pipe
- Adopt suitable pipe diameter
- Adopt nearby condensate water discharge

6.2 Key points of drainage water pipe installation

6.2.1 Considering the pipeline route and elevation

- Before installing condensate water pipeline, determine its route and elevation to avoid intersection with other pipelines and ensure slope is straight.

6.2.2 Drainage pipe selection

- The drainage pipe diameter shall not small than the drain hose of indoor unit
- According to the water flowrate and drainage pipe slope to choose the suitable pipe, the water flowrate is decided by the capacity of indoor unit.

Relationship between water flowrate and capacity of indoor unit

Capacity (x1000Btu)	Water flowrate (l/h)
12	2.4
18	4
24	6
36	8
48	12
60	14

According to the above table to calculate the total water flowrate for the confluence pipe selection.

For horizontal drainage pipe (The following table is for reference)

PVC pipe	Reference value of inner diameter of pipe (mm)	Allowable maximum water flowrate (l/h)		Remark
		Slope 1/50	Slope 1/100	
PVC25	20	39	27	For branch pipe
PVC32	25	70	50	
PVC40	31	125	88	Could be used for confluence pipe
PVC50	40	247	175	
PVC63	51	473	334	

Attention: Adopt PVC40 or bigger pipe to be the main pipe.

For Vertical drainage pipe (The following table is for reference)

PVC pipe	Reference value of inner diameter of pipe (mm)	Allowable maximum water flowrate (l/h)	Remark
PVC25	20	220	For branch pipe
PVC32	25	410	
PVC40	31	730	Could be used for confluence pipe
PVC50	40	1440	
PVC63	51	2760	
PVC75	67	5710	
PVC90	77	8280	

Attention: Adopt PVC40 or bigger pipe to be the main pipe.

6.2.3 Individual design of drainage pipe system

- The drainage pipe of air conditioner shall be installed separately with other sewage pipe, rainwater pipe and drainage pipe in building.
- The drainage pipe of the indoor unit with water pump should be apart from the one without water pump.

6.2.4 Supporter gap of drainage pipe

- In general, the supporter gap of the drainage pipe horizontal pipe and vertical pipe is respectively 1m~1.5m and 1.5m~2.0m.
- Each vertical pipe shall be equipped with not less than two hangers.
- Overlarge hanger gap for horizontal pipe shall create bending, thus leading to air block.

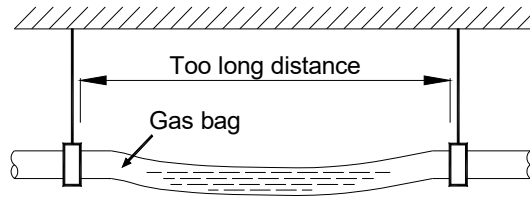

6.2.5 The horizontal pipe layout should avoid converse flow or bad flow

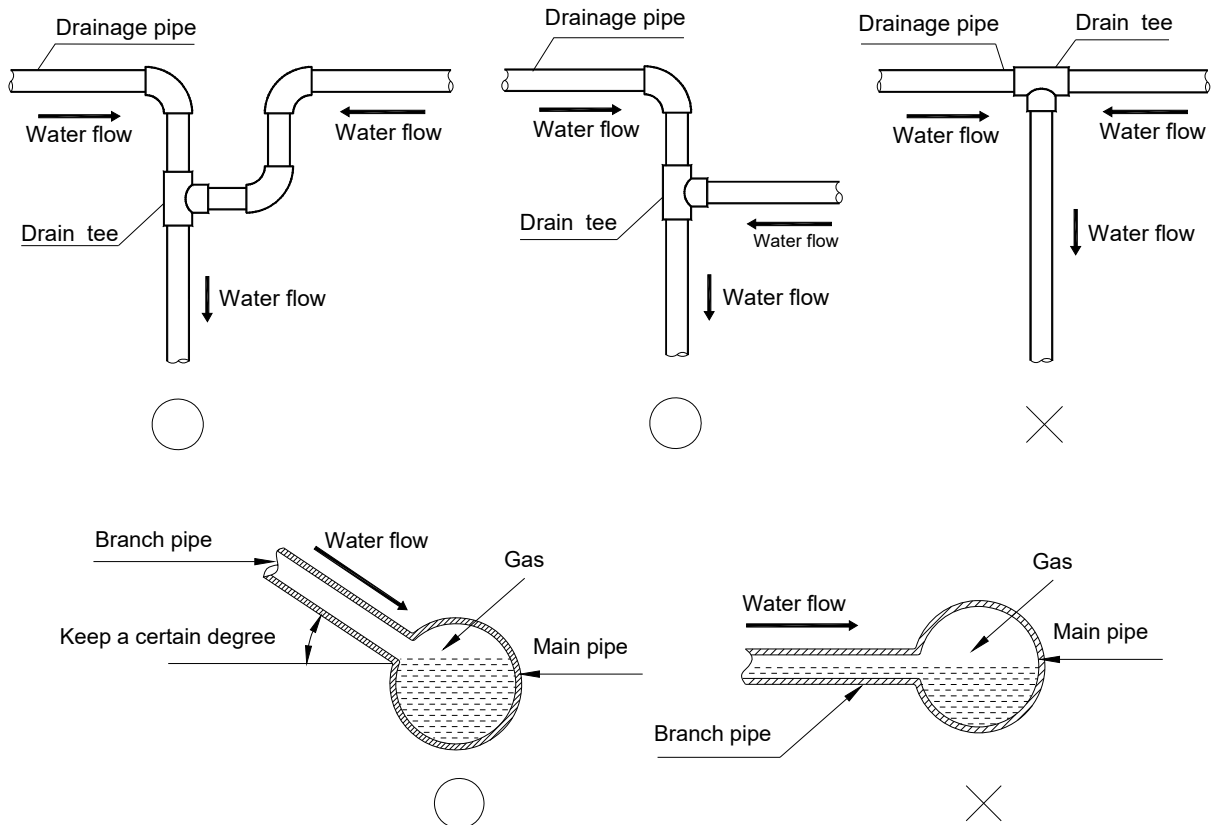

- The correct installation will not cause converse water flow and the slope of the branch pipes can be adjusted freely
- The false installation will cause converse water flow and the slope of the branch pipe can not be adjusted.

6.2.6 Water storage pipe setting

- If the indoor unit has high extra static pressure and without water pump to elevate the condensate water, such as high extra static pressure duct unit , the water storage pipe should be set to avoid converse flow or blow water phenomena.

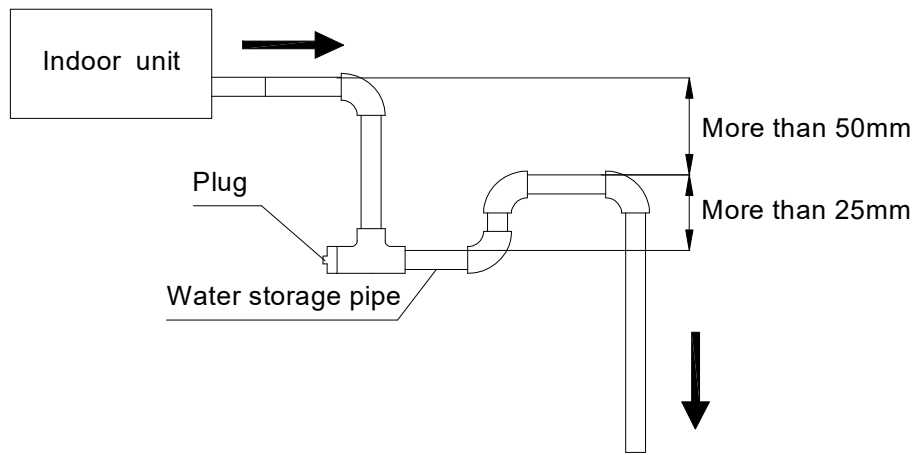

6.2.7 Lifting pipe setting of indoor unit with water pump

- The length of lifting pipe should not exceed the pump head of indoor unit water pump.
Pump head of big four way cassette: 750mm
Pump head of compact four way cassette: 500mm
- The drainage pipe should be set down inclined after the lifting pipe immediately to avoid wrong operation of water level switch.
- Refer the following picture for installation reference.

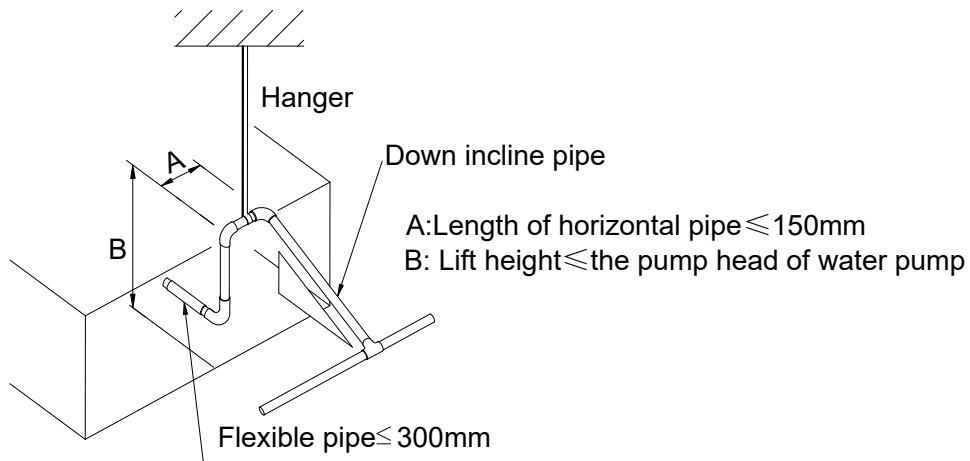

6.2.8 Blowhole setting

- For the concentrated drainage pipe system, there should design a blowhole at the highest point of main pipe to ensure the condensate water discharge smoothly.
- The air outlet shall face down to prevent dirt entering pipe.
- Each indoor unit of the system should be installed it.
- The installation should be considering the convenience for future cleaning.

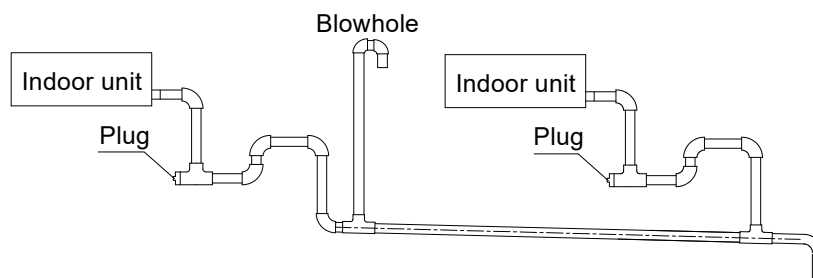

6.2.9 The end of drainage pipe shall not contact with ground directly.

6.3 Drainage test

6.3.1 Water leakage test

After finishing the construction of drainage pipe system, fill the pipe with water and keep it for 24 hours to check whether there is leakage at joint section.

6.3.2 Water discharge test

1. Natural drainage mode(the indoor unit with outdoor drainage pump)
Infuse above 600ml water through water test hole slowly into the water collector, observe whether the water can discharge through the transparent hard pipe at drainage outlet.
2. Pump drainage mode
- 2.1 Disconnect the plug of water level switch, remove the cover of water test hole and slowly infuse about 2000ml water through the water test hole, be sure that the water will not touch the motor of drainage pump.

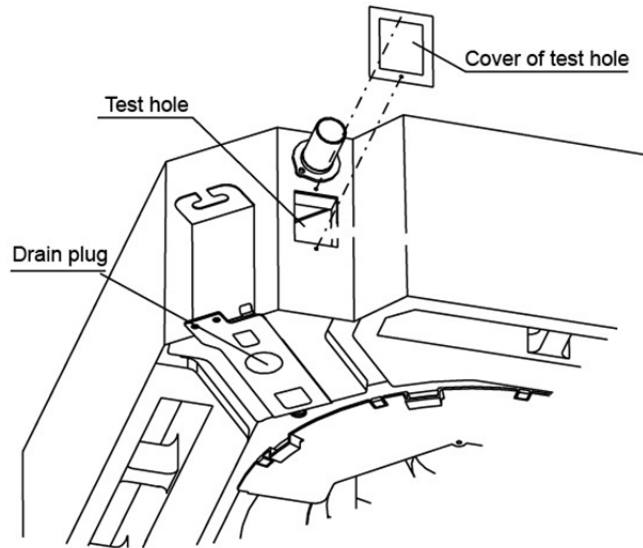

- 2.2 Power on and let the air conditioner operate for cooling. Check operation status of drainage pump, and then connect the plug of water level switch, check the operation sound of water pump and observe whether the water can discharge through the transparent hard pipe at drainage outlet. (In light of the length of drainage pipe, water shall be discharged about 1 minute delayed)
- 2.3 Stop the operation of air conditioner, power off the power supply and put the cover of water test hole back to the original place.
 - a. After stopped the air conditioner 3 minutes, check whether there is anything abnormal. If drainage pipes have not been distributed properly, over back-flow water shall cause the flashing of alarm indicator at remote-controlled receiving board and even water shall run over the water collector.
 - b. Continuously infusing water until water level alarmed, check whether the drainage pump could discharge water at once. If water level does not decline under warning water level 3 minutes later, it shall cause shutdown of unit. When this situation happens, the normal startup only can be recovered by turning down power supply and eliminating accumulated water.

Note: Drain plug at the main water-containing plate is used for eliminating accumulated water in water-containing plate when maintaining air conditioner fault. During normal operation, the plug shall be filled in to prevent leakage.

6.4 Insulation work of drainage pipe

Refer the introduction to the insulation engineering parts.

7. Vacuum Drying and Leakage Checking

7.1 Purpose of vacuum drying

- Eliminating moisture in system to prevent the phenomena of ice-blockage and copper oxidation. Ice-blockage shall cause abnormal operation of system, while copper oxide shall damage compressor.
- Eliminating the non-condensable gas (air) in system to prevent the components oxidizing, pressure fluctuation and bad heat exchange during the operation of system.

7.2 Selection of vacuum pump

- The ultimate vacuum degree of vacuum pump shall be -756mmHg or above.
- Precision of vacuum pump shall reach 0.02mmHg or above.

7.3 Operation procedure for vacuum drying

Due to different construction environment, two kinds of vacuum drying ways could be chosen, namely ordinary vacuum drying and special vacuum drying.

7.3.1 Ordinary vacuum drying

1. When conduct first vacuum drying, connect pressure gauge to the infusing mouth of gas pipe and liquid pipe, and keep vacuum pump running for 1hour (vacuum degree of vacuum pump shall be reached -755mmHg).
2. If the vacuum degree of vacuum pump could not reach -755mmHg after 1 hour of drying, it indicates that there is moisture or leakage in pipeline system and need to go on with drying for half an hour.
3. If the vacuum degree of vacuum pump still could not reach -755mmHg after 1.5 hours of drying, check whether there is leakage source.
4. Leakage test: After the vacuum degree reaches -755mmHg, stop vacuum drying and keep the pressure for 1 hour. If the indicator of vacuum gauge does not go up, it is qualified. If going up, it indicates that there is moisture or leak source.

7.3.2 Special vacuum drying

The special vacuum drying method shall be adopted when:

1. Finding moisture during flushing refrigerant pipe.
2. Conducting construction on rainy day, because rain water might penetrated into pipeline.
3. Construction period is long, and rain water might penetrated into pipeline.
4. Rain water might penetrate into pipeline during construction.

Procedures of special vacuum drying are as follows:

1. Vacuum drying for 1 hour.
2. Vacuum damage, filling nitrogen to reach 0.5Kgf/cm² .
Because nitrogen is dry gas, vacuum damage could achieve the effect of vacuum drying, but this method could not achieve drying thoroughly when there is too much moisture. Therefore, special attention shall be drawn to prevent the entering of water and the formation of condensate water.
3. Vacuum drying again for half an hour.
If the pressure reached -755mmHg, start to pressure leakage test. If it can not reached the value, repeat vacuum damage and vacuum drying again for 1 hour.
4. Leakage test: After the vacuum degree reaches -755mmHg, stop vacuum drying and keep the pressure for 1 hour. If the indicator of vacuum gauge does not go up, it is qualified. If going up, it indicates that there is moisture or leak source.

8. Additional refrigerant charge

- After the vacuum drying process is carried out, the additional refrigerant charge process need to be performed.
- The outdoor unit is factory charged with refrigerant. The additional refrigerant charge volume is decided by the diameter and length of the liquid pipe between indoor and outdoor unit. Refer the following formula to calculate the charge volume.

Diameter of liquid pipe (mm)	Φ6.35	Φ9.52	Φ12.7
Formula	$V=15g/m \times (L-5)$	$V=30g/m \times (L-5)$	$V=65g/m \times (L-5)$

V: Additional refrigerant charge volume (g).

L : The length of the liquid pipe (m).

Note:

- Refrigerant may only be charged after performed the vacuum drying process.
- Always use gloves and glasses to protect your hands and eyes during the charge work.
- Use electronic scale or fluid infusion apparatus to weight refrigerant to be recharged. Be sure to avoid extra refrigerant charged, it may cause liquid hammer of the compressor or protections.
- Use supplementing flexible pipe to connect refrigerant cylinder, pressure gauge and outdoor unit. And The refrigerant should be charged in liquid state. Before recharging, The air in the flexible pipe and manifold gauge should be exhausted.
- After finished refrigerant recharge process, check whether there is refrigerant leakage at the connection joint part.(Using gas leakage detector or soap water to detect).

9. Engineering of insulation

9.1 Insulation of refrigerant pipe

9.1.1 Operational procedure of refrigerant pipe insulation

Cut the suitable pipe → insulation (except joint section) → flare the pipe → piping layout and connection → vacuum drying → insulate the joint parts

9.1.2 Purpose of refrigerant pipe insulation

- During operation, temperature of gas pipe and liquid pipe shall be over-heating or over-cooling extremely. Therefore, it is necessary to carry out insulation; otherwise it shall debase the performance of unit and burn compressor.
- Gas pipe temperature is very low during cooling. If insulation is not enough, it shall form dew and cause leakage.
- Temperature of gas pipe is very high (generally 50-100°C) during heating. Insulation work must be carried out to prevent hurt by carelessness touching.

9.1.3 Insulation material selection for refrigerant pipe

- The burning performance should over 120°C
- According to the local law to choose insulation materials
- The thickness of insulation layer shall be above 10mm. If in hot or wet environment place, the layer of insulation should be thicker accordingly.

9.1.4 Installation highlights of insulation construction

- Gas pipe and liquid pipe shall be insulated separately, if the gas pipe and liquid pipe were insulated together; it will decrease the performance of air conditioner.

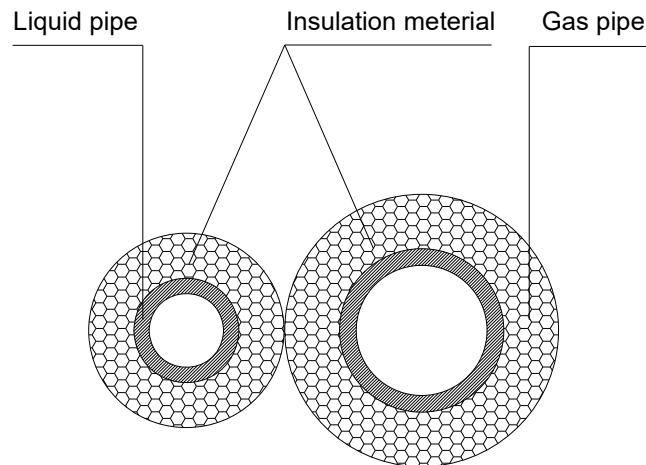

- The insulation material at the joint pipe shall be 5~10cm longer than the gap of the insulation material.
- The insulation material at the joint pipe shall be inserted into the gap of the insulation material.
- The insulation material at the joint pipe shall be banded to the gap pipe and liquid pipe tightly.
- The linking part should be use glue to paste together
- Be sure not bind the insulation material over-tight, it may extrude out the air in the material to cause bad insulation and cause easy aging of the material.

9.2 Insulation of drainage pipe

9.2.1 Operational procedure of refrigerant pipe insulation

Select the suitable pipe → insulation (except joint section) → piping layout and connection → drainage test → insulate the joint parts

9.2.2 Purpose of drainage pipe insulation

The temperature of condensate drainage water is very low. If insulation is not enough, it shall form dew and cause leakage to damage the house decoration.

9.2.3 Insulation material selection for drainage pipe

- The insulation material should be flame retardant material, the flame retardancy of the material should be selected according to the local law.
- Thickness of insulation layer is usually above 10mm.
- Use specific glue to paste the seam of insulation material, and then bind with adhesive tape. The width of tape shall not be less than 5cm. Make sure it is firm and avoid dew.

9.2.4 Installation and highlights of insulation construction

- The single pipe should be insulated before connecting to another pipe, the joint part should be insulated after the drainage test.
- There should be no insulation gap between the insulation material.

10. Engineering of electrical wiring

10.1 Highlights of electrical wiring installation

- All field wiring construction should be finished by qualified electrician.
- Air conditioning equipment should be grounded according to the local electrical regulations.
- Current leakage protection switch should be installed.
- Do not connect the power wire to the terminal of signal wire.
- When power wire is parallel with signal wire, put wires to their own wire tube and remain at least 300mm gap.
- According to table in indoor part named "the specification of the power" to choose the wiring, make sure the selected wiring not small than the date showing in the table.
- Select different colors for different wire according to relevant regulations.
- Do not use metal wire tube at the place with acid or alkali corrosion, adopt plastic wire tube to replace it.
- There must be not wire connect joint in the wire tube If joint is a must, set a connection box at the place.
- The wiring with different voltage should not be in one wire tube.
- Ensure that the color of the wires of outdoor and the terminal No. are same as those of indoor unit respectively.

11. Test operation

11.1 The test operation must be carried out after the entire installation has been completed.

11.2 Please confirm the following points before the test operation.

- The indoor unit and outdoor unit are installed properly.
- Tubing and wiring are correctly completed.
- The refrigerant pipe system is leakage-checked.
- The drainage is unimpeded.
- The ground wiring is connected correctly.
- The length of the tubing and the added stow capacity of the refrigerant have been recorded.
- The power voltage fits the rated voltage of the air conditioner.
- There is no obstacle at the outlet and inlet of the outdoor and indoor units.
- The gas-side and liquid-side stop valves are both opened.
- The air conditioner is pre-heated by turning on the power.

11.3 Test operation

Set the air conditioner under the mode of "COOLING" by remote controller, and check the following points.

Indoor unit

- Whether the switch on the remote controller works well.
- Whether the buttons on the remote controller works well.
- Whether the air flow louver moves normally.
- Whether the room temperature is adjusted well.
- Whether the indicator lights normally.
- Whether the temporary buttons works well.
- Whether the drainage is normal.
- Whether there is vibration or abnormal noise during operation.

Outdoor unit

- Whether there is vibration or abnormal noise during operation.
- Whether the generated wind, noise, or condensed of by the air conditioner have influenced your neighborhood.
- Whether any of the refrigerant is leaked.

Part 5

Electrical Control System

1. Electrical Control Function	169
2. Troubleshooting	177

1. Electrical Control Function

1.1 Abbreviation

- T1: Indoor room temperature
T2: Evaporator coil temperature
T3: Condenser coil temperature
T4: Outdoor ambient temperature
T5: Compressor discharge temperature
Ts: Setting temperature

1.2 Main Protection

1.2.1 Compressor Restart Delay

1.2.2 Sensor protection at open circuit and breaking disconnection.

1.2.3 Phase check function(for 3-phase models)

If the phase sequence is detected wrong or lack of 1 or 2 phase, the unit won't start and there is error code displayed on outdoor PCB.

1.2.4 Low pressure check function(for 48-60K models)

The low pressure switch should be always closed. If it is open, the system will stop until the fault is cleared. Within 5 minutes after the compressor starts and 4 minutes after defrosting ends, low pressure switch won't be checked.

Note: If this protection occurs 3 times within 20 minutes, it won't recover automatically until the main power is cut off.

1.2.5 Over-current protection(for 48-60K models)

When compressor is running, if the current is over twice of the rated for 3 seconds, the compressor will stop and an error code will be displayed on the outdoor PCB. If the current becomes normal, the compressor will restart after 3 minutes.

1.3 Operation Modes and Functions

1.3.1 Fan mode

- Outdoor fan and compressor cease operation.
- Temperature setting function is disabled, and no preset temperature is displayed.
- Indoor fan can be set to high, (medium), low, or auto.
- Louver operates the same as in cooling mode.
- Auto fan:

For floor standing units:

Auto fan will be controlled in line with cooling auto fan with temperature set to be 24°C.

For other units:

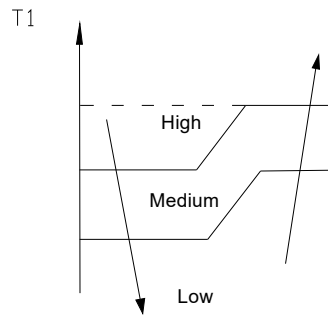

1.3.2 Cooling Mode

1.3.2.1 Compressor Running Guidelines

Once the compressor starts up, it will follow the below rules:

When $T1-Ts$ is higher than setting value, the compressor and outdoor fan cease operation. When $T1-Ts$ is lower than setting value, the compressor and outdoor fan activate..

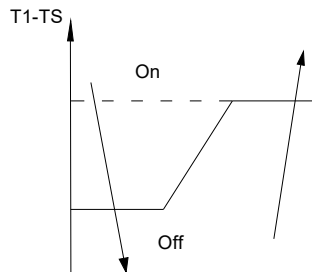

1.3.2.2 Outdoor Fan Running Guidelines

For single-fan units:

The outdoor fan will run following the compressor

For double-fan units:

The outdoor fans run depending on T3.

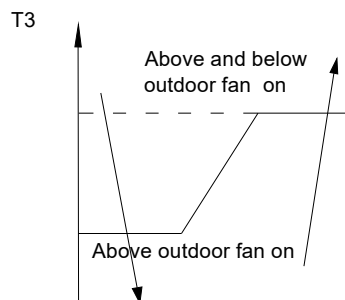

1.3.2.3 Indoor Fan Running Guidelines

In cooling mode, the indoor fan runs continuously. You can select the following speeds: high, (medium), low, or auto.

The auto fan acts according to the following principles:

For floor standing units:

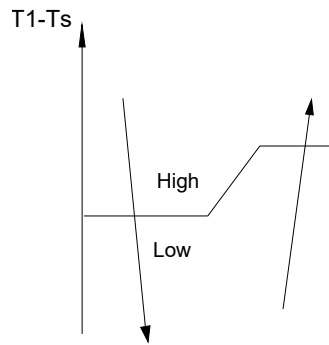

For other units:

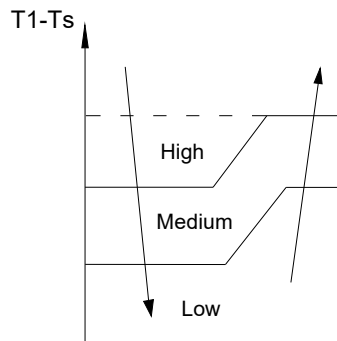

1.3.2.4 Low evaporator coil temperature T2 protection

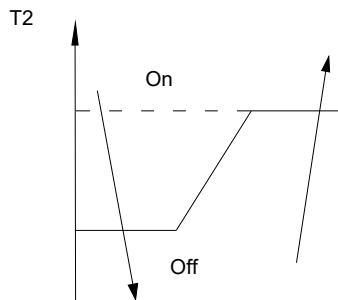

When the evaporator temperature goes below a preset value, the compressor stops.

1.3.2.5 Condenser high temperature T3 protection

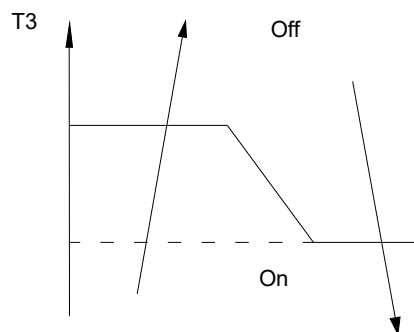

When condenser temperature exceeds the preset value, the compressor stops.

1.3.3 Heating Mode

1.3.3.1 Compressor Running Guidelines

Once the compressor starts up, it keeps running 7 minutes, then it will follow the below rules:

When T1-Ts is higher than setting value, the compressor and outdoor fan will shut off. When T1-Ts is lower than setting value, the compressor and outdoor fan will start up.

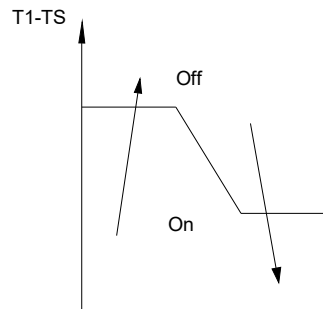

1.3.3.2 Outdoor Fan Running Guidelines

For single-fan units:

The outdoor fan will run following the compressor

For double-fan units:

The outdoor fans run depending on T4.

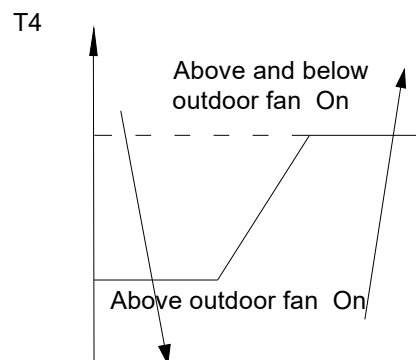

1.3.3.3 Indoor Fan Running Guidelines

When the compressor is on, the indoor fan can select the following speeds: high, (medium), low, or auto.. And the anti-cold wind function has the priority.

The auto fan acts according to the following principles:

For floor-standing units:

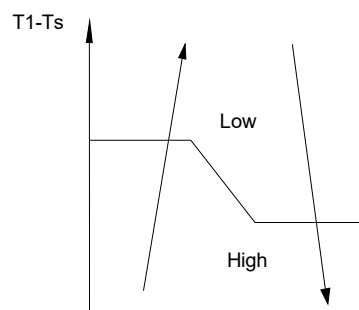

For other units:

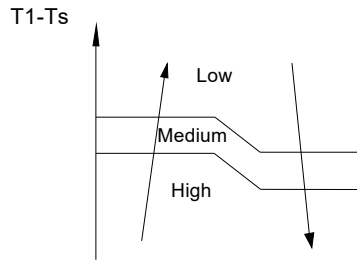

1.3.3.4 Defrosting mode :

the unit enters the defrosting mode according to the value of T3 and T4 as well as the compressor running time.

● **Defrosting action :**

For 12~30K floor-standing units:

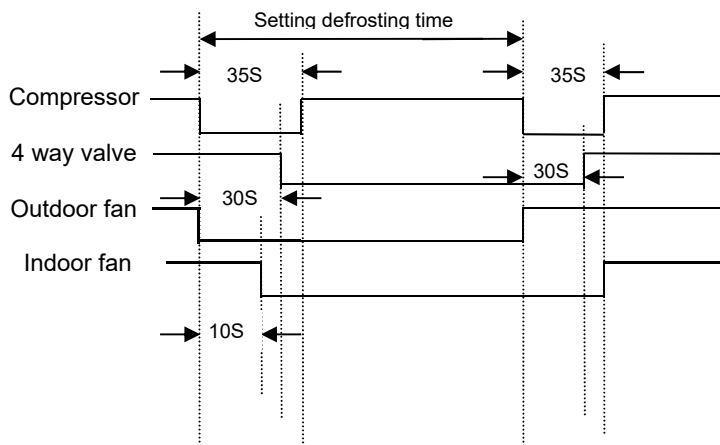

For 12~30 other units:

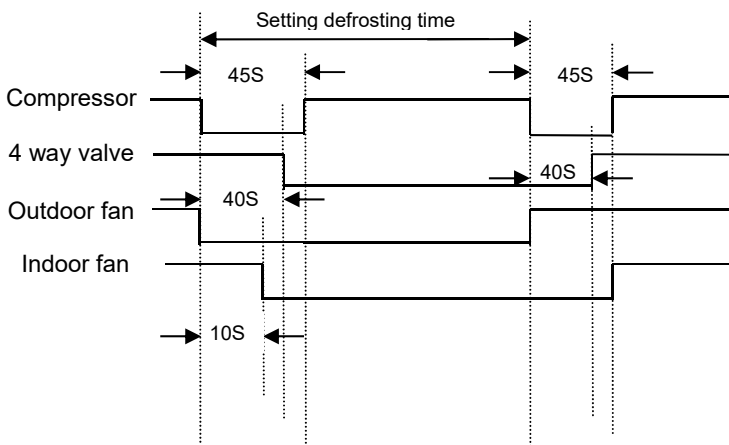

For 36~60K

In defrosting mode, the compressor continues to run, the indoor and outdoor motor stops

1.3.3.5 High evaporator coil temp.T2 protection:

For floor-standing units:

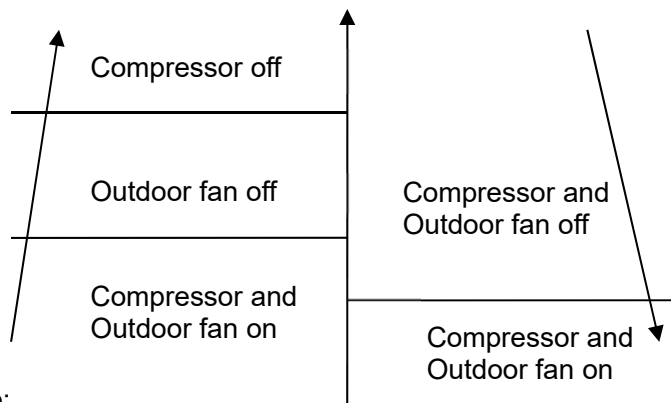
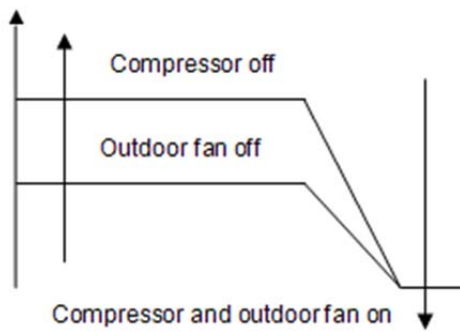

For Ceiling & floor type:

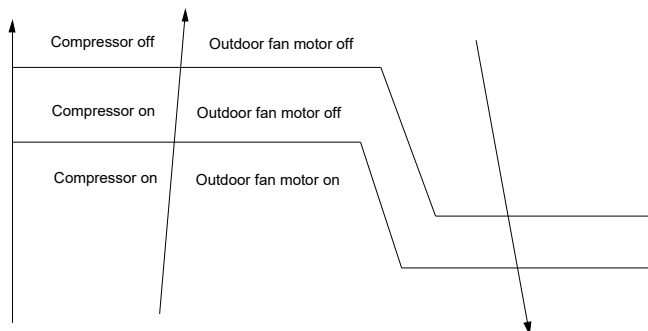

For other units:

1.3.4 Auto Mode

This mode can be selected with the remote controller and the temperature setting can be adjusted between 17°C~30°C

In auto mode, the machine selects cooling, heating, or fan-only mode on the basis of ΔT ($\Delta T = T1 - Ts$).

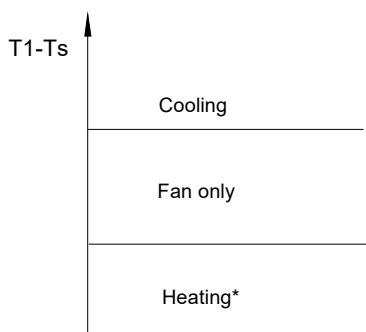

Heating*: In auto mode, cooling only models run the fan.

Indoor fans run at the auto fan speed of the relevant mode.

The louver operates the same as in relevant mode.

If the machine switches mode between heating and cooling, the compressor pauses for a certain period of time intermittently and then selects a mode based on T1-Ts.

If the setting temperature is modified, the machine selects a new running function.

1.3.5 Dehumidifier Mode

1.3.5.1 Indoor fan speed is fixed at low and cannot be changed

1.3.5.2 All protections are activated and operate the same as they do in cooling mode.

1.3.5.3 The louver operates the same as in cooling mode.

1.3.6 Timer function

1.3.6.1 The timing range is 24 hours.

1.3.6.2 Timer On. The machine turns on automatically at the preset time.

1.3.6.3 Timer Off. The machine turns off automatically at the preset time.

1.3.6.4 Timer On/Off. The machine turns on automatically at the preset On Time, and then turns off automatically at the preset Off Time.

1.3.6.5 Timer Off/On. The machine turns on automatically at the preset Off Time and then turns off automatically at the preset On Time.

1.3.6.6 The timer does not change the unit operation mode. If the unit is off now, it does not start up immediately after the "timer off" function is set. When the setting time is reached, the timer LED switches off and the unit running mode remains unchanged.

1.3.6.7 The timer uses relative time, not clock time.

1.3.7 Sleep function

1.3.7.1 The sleep function is available in cooling, heating, or auto mode.

1.3.7.2. The operational process for sleep mode is as follows:

When cooling, the temperature rises 1°C (to not higher than 30°C) every hour. After 2 hours, the temperature stops rising and the indoor fan is fixed to auto speed.

When heating, the temperature decreases 1°C (to not lower than 17°C) every hour. After 2 hours, the temperature stops decreasing and the indoor fan is fixed at auto speed. Anti-cold wind function takes priority.

1.3.7.3 The operating time for sleep mode is 7 hours, after which, the unit exits this mode and switches off.

1.3.7.4 The timer setting is available in this mode.

1.3.8 Auto-Restart function

The indoor unit has an auto-restart module that allows the unit to restart automatically. The module automatically stores the current settings (not including the Swing setting) and, in the case of a sudden power failure, will restore those settings automatically within 3 minutes after power returns.

1.3.9 Drain Pump Control (For Duct and Cassette)

Use the water-level switch to control drain pump.

The system checks the water level every 5 seconds.

---When the A/C operates in cooling (including auto cooling) or forced cooling mode, the pump begins running immediately and continuously until cooling stops.

---If the water level increases up to the control point, the LED displays an alarm code and the drain pump opens and continually monitors the water level. If the water level falls and LED alarm code is no longer displayed (drain pump close delay is 1 minute), the unit goes back into its last mode. Otherwise, the entire system (including the pump) stops and the LED displays an alarm again after 3 minutes.

2. Troubleshooting

2.1 Display board

2.1.1 Display board of MSP Duct & HSP Duct

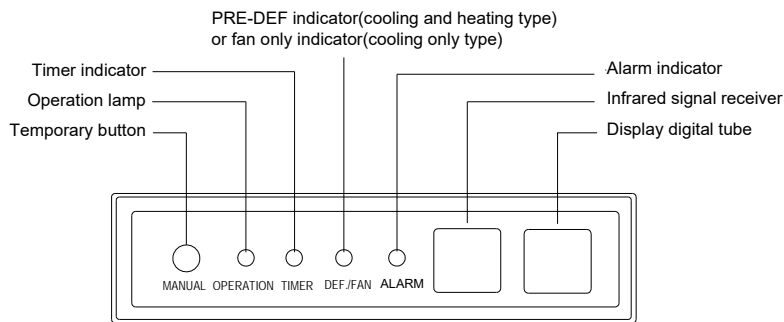

2.1.2 Display board of super slim cassette

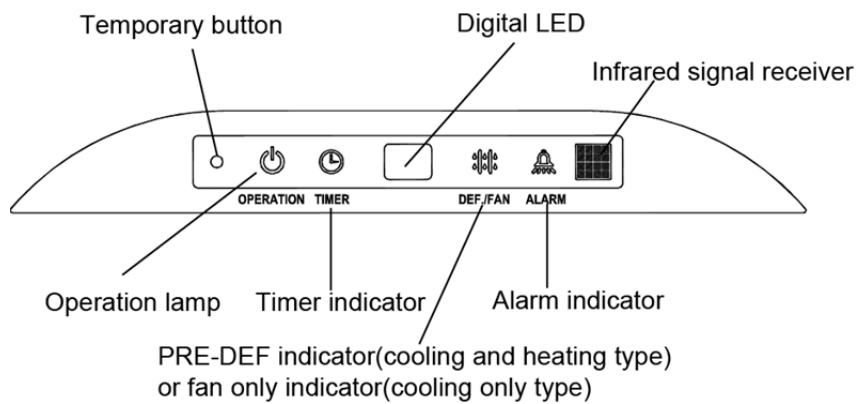

2.1.3 Display board of ceiling & Floor

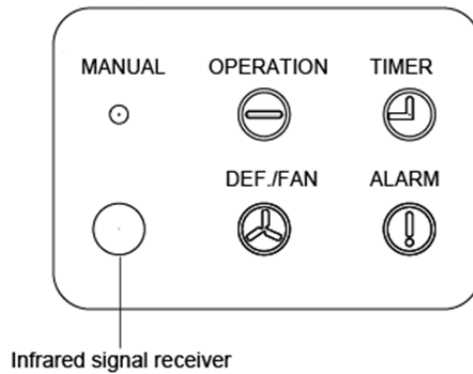

2.1.4 Display board of Compact cassette

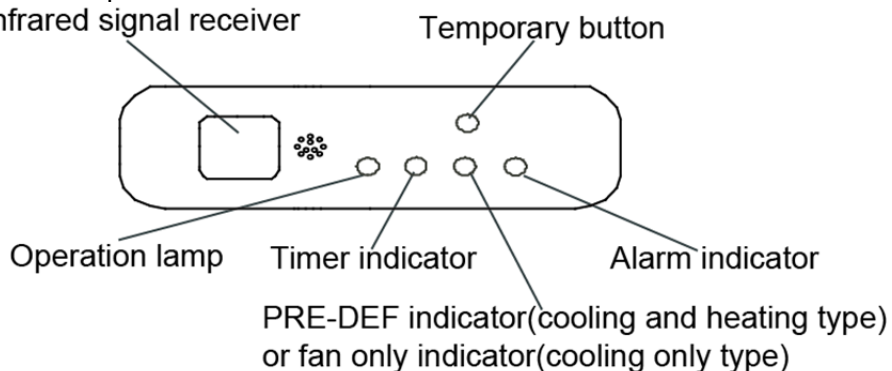



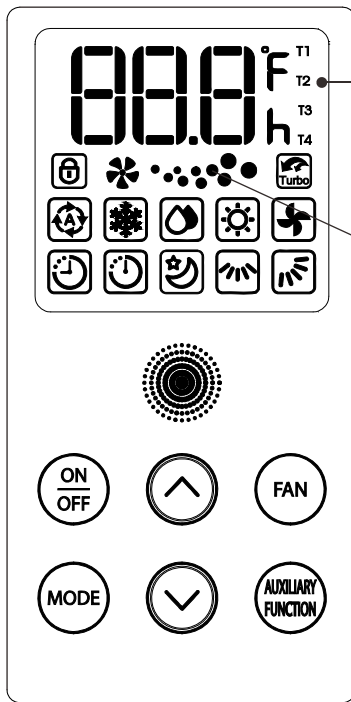









2.1.5 Display board of floor-standing



Room Temp /Set Temp /Set Timer display

Fan speed operation display

Indicators

-  Auto operation display
-  Cooling operation display
-  Dry operation display
-  Heating operation display
-  Fan operation display
-  Vertical airflow display(optional)
-  Horizontal airflow display
-  Sleep operation display
-  Turbo operation display(optional)
-  Off timer operation display
-  On timer operation display
-  Lock operation display

2.2. Self-diagnosis

Indoor unit's LED indication

During malfunction or protection, the indicators and digital LED displays as follow:

For MSP Duct (MTB), HSP Duct, Ceiling & floor type:

No	Malfunction or protection	Operation	Timer	Def/Fan	Alarm	Digital LED Display
1	T1 temperature sensor open or short circuit	X	☆	X	X	E2
2	T2 temperature sensor open or short circuit	☆	X	X	X	E3
3	T3 temperature sensor open or short circuit	X	X	☆	X	E4
4	Indoor EEPROM malfunction	☆	☆	X	X	E7

O (on) X(off) ☆(flash at 5Hz)
Note: Digital display is available for duct type.

For Super-slim 4-way Cassette Type:

NO.	Malfunction	Running lamp	Timer lamp	Defrosting lamp	Alarm lamp	Display(digital tube)
1	T1 temperature sensor open or short circuit	X	☆	X	X	E2
2	T2 temperature sensor open or short circuit	☆	X	X	X	E3
3	T3 temperature sensor open or short circuit	X	X	☆	X	E4
4	Indoor EEPROM malfunction	☆	☆	X	X	E7
5	Water level alarm	X	X	X	☆	E8
6	Communication error between auto-lifting panel and slim cassette	☆	X	☆	☆	F0
7	Auto-lifting panel is faulty (for slim cassettes with an auto-lifting panel)	X	☆	☆	☆	F1
8	Auto-lifting panel is not closed (for slim cassettes with an auto-lifting panel)	X	O	☆	☆	F2

O (on) X(off) ☆(flash at 5Hz)

For Compact cassette Type:

NO.	Malfunction	Running lamp	Timer lamp	Defrosting lamp	Alarm lamp
1	T1 temperature sensor open or short circuit	X	☆	X	X
2	T2 temperature sensor open or short circuit	☆	X	X	X
3	T3 temperature sensor open or short circuit	X	X	☆	X
4	Indoor EEPROM malfunction	☆	☆	X	X
5	Water level alarm	X	X	X	☆

O (on) X(off) ☆(flash at 5Hz)

For MSP Duct (MTI):

Malfunction	Error Code	Timer Lamp	Operation Lamp (flashes)
Indoor EEPROM malfunction	E0	X	1
T1 temperature sensor open or short circuit	E4	X	5
T2 temperature sensor open or short circuit	E5	X	6
Refrigerant leakage detection	EC	X	7
Water level alarm malfunction	EE	X	8
T3 temperature sensor open or short circuit	F2	O	3
Dual chips communication malfunction	FA	O	11

O (on) X(off)

For Floor-standing type:

Codes	Contents
P4	Indoor evaporator temperature protection
P5	Outdoor condenser temperature protection
P9	Anti-cold wind(for S2, it means defrosting)
E1	T1 temperature sensor open or short circuit
E2	T2 temperature sensor open or short circuit
E3	T3 temperature sensor open or short circuit
E6	Outdoor unit malfunction
HS	Defrosting
P0	Communication malfunction between indoor main PCB and display PCB(J2,S4)

LEDs' for the indication of outdoor trouble(for 36-60K models)

Type	Contents	LED1	LED2	LED3
Trouble	Phase sequence	Flash	Off	Off
Trouble	Lack of phase(A,B)	Flash	Off	Off
Trouble	Lack of phase(C)	Off	Off	Off
Trouble	Low pressure protection	Flash	Flash	Off
Trouble	Overload of current	Off	Off	Flash
Trouble	T3 temperature sensor open or short circuit	Off	Flash	Flash
Trouble	Temperature sensor open or short circuit of T4 or T5 or high pressure protection	Off	Flash	Off
Trouble	High temperature protection of condenser	Flash	Flash	Flash

Note:

1. If the LED1-LED3 are flashing slowly, means the system is stand-by.
2. T3: Outdoor condenser temperature sensor
3. T4: Outdoor ambient temperature sensor

2.3. Solving steps for typical malfunction

(1) For indoor unit

a. T1 or T2 temperature sensor open or short circuit

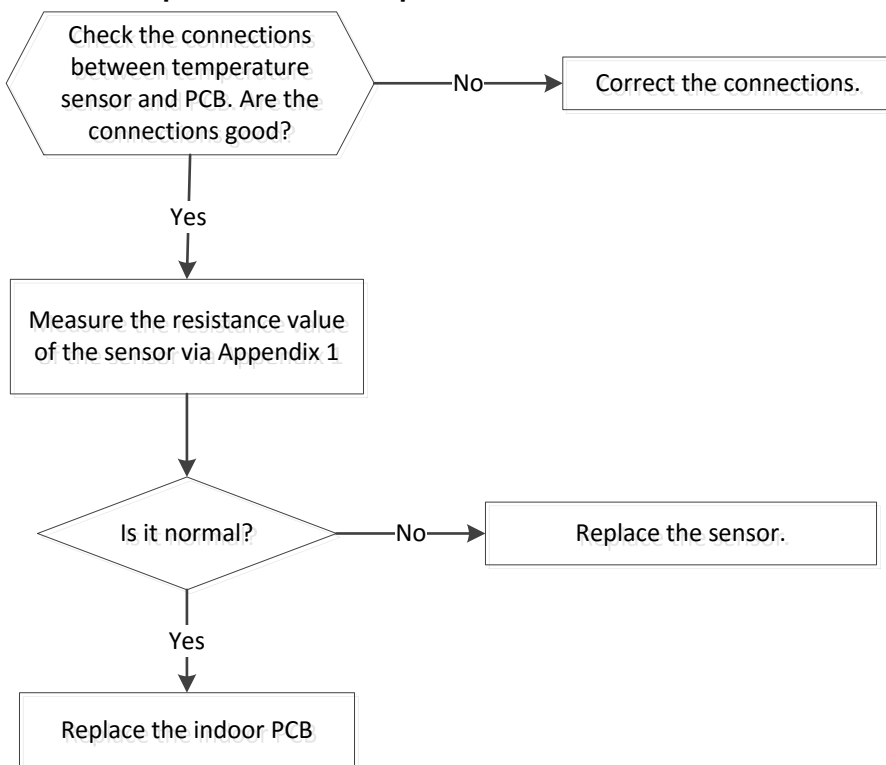

b. T3 temperature sensor open or short circuit

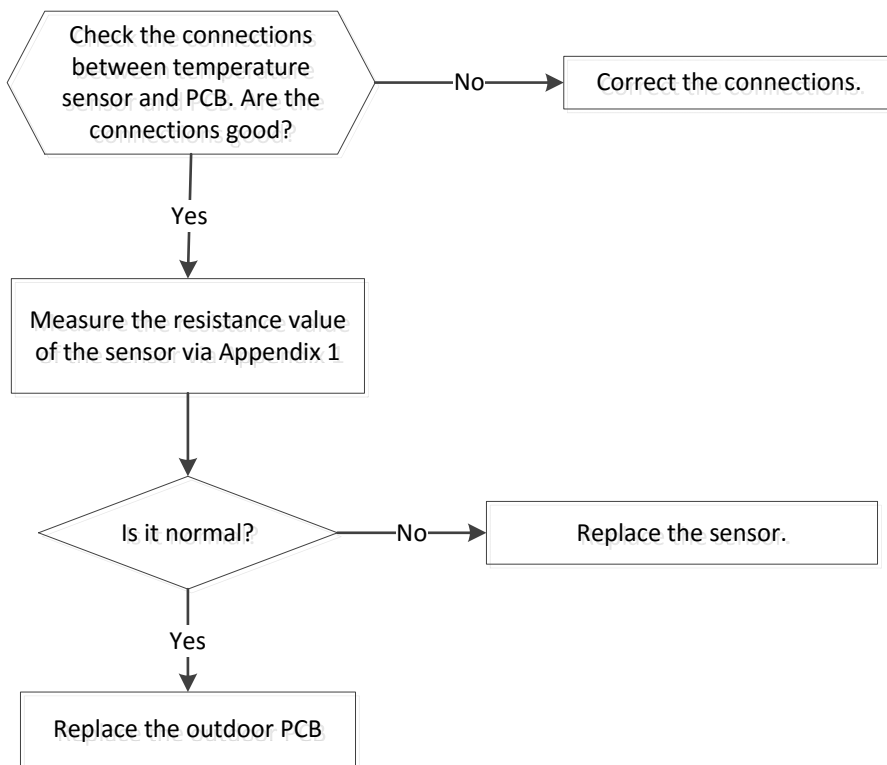

c. Indoor EEPROM malfunction

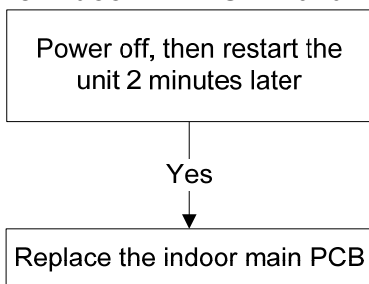

EEPROM: An electrically erasable programmable read-only memory whose contents can be erased and reprogrammed using a pulsed voltage.

d. Water level alarm

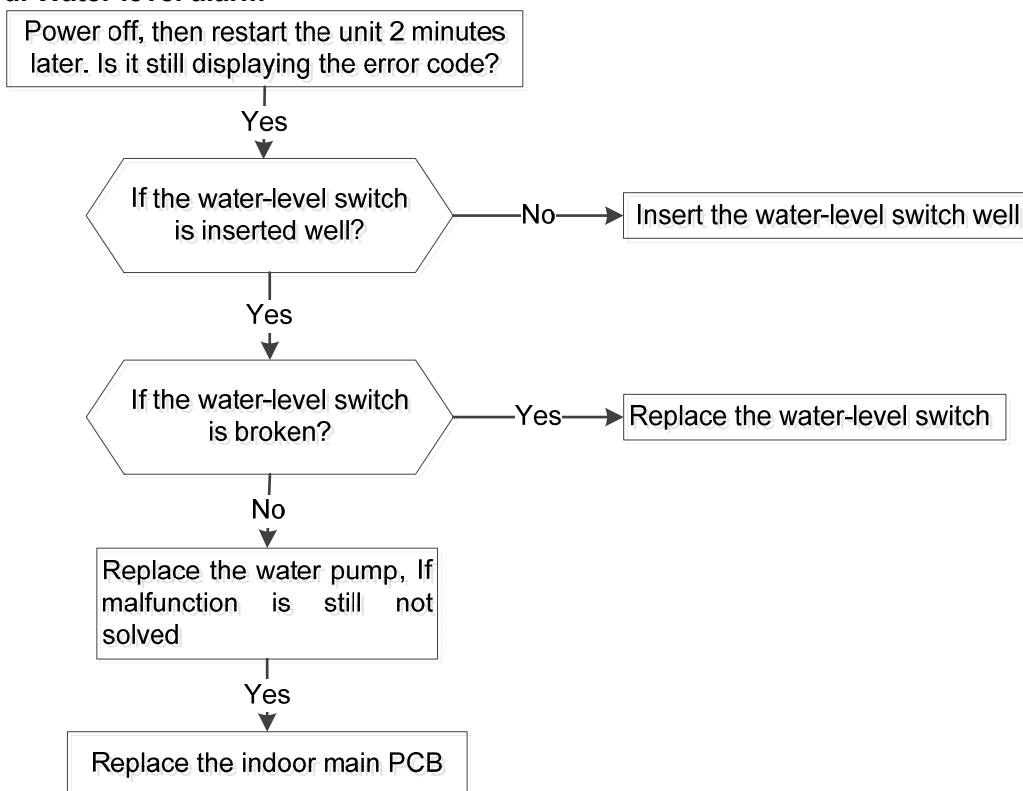

e. Communication malfunction between indoor main PCB and display PCB

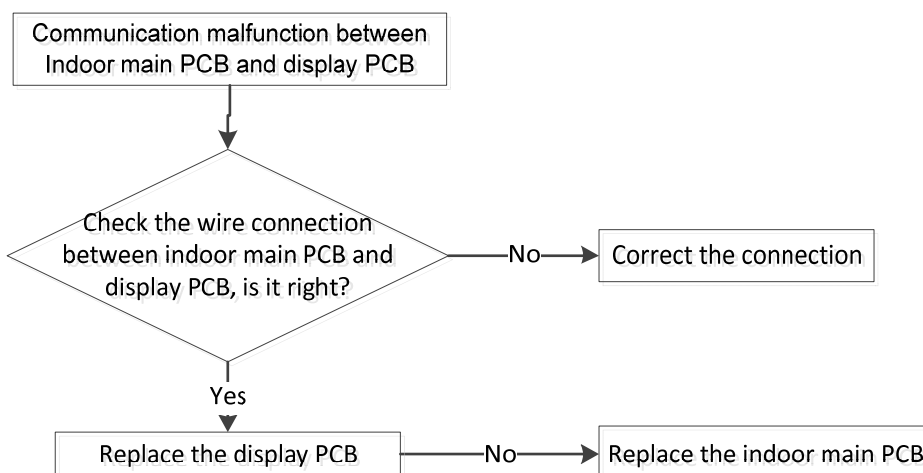

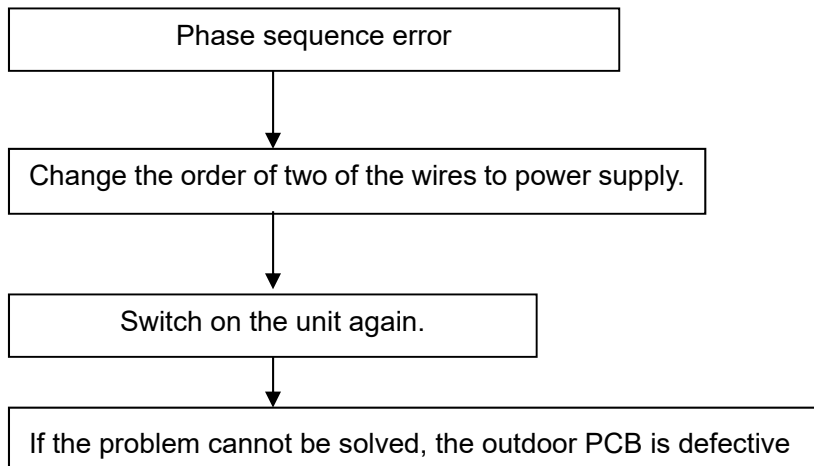
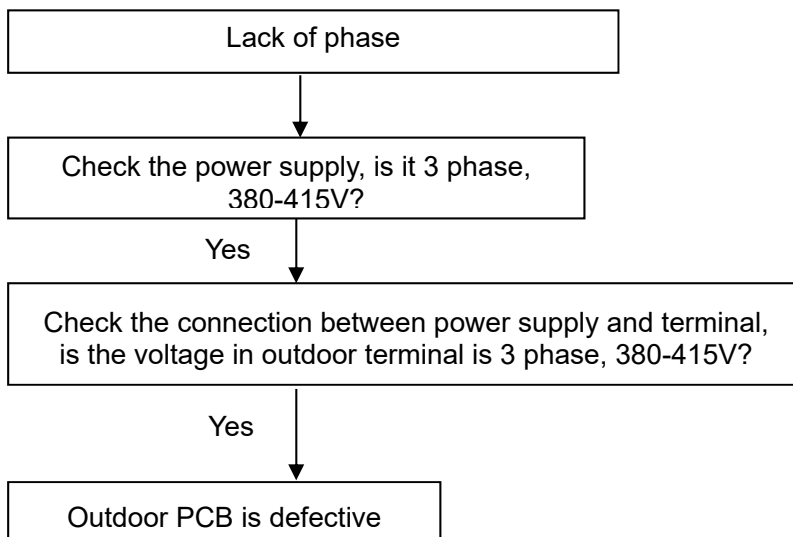
(2) For the outdoor unit**a. Phase sequence error:****b. Lack of phase**

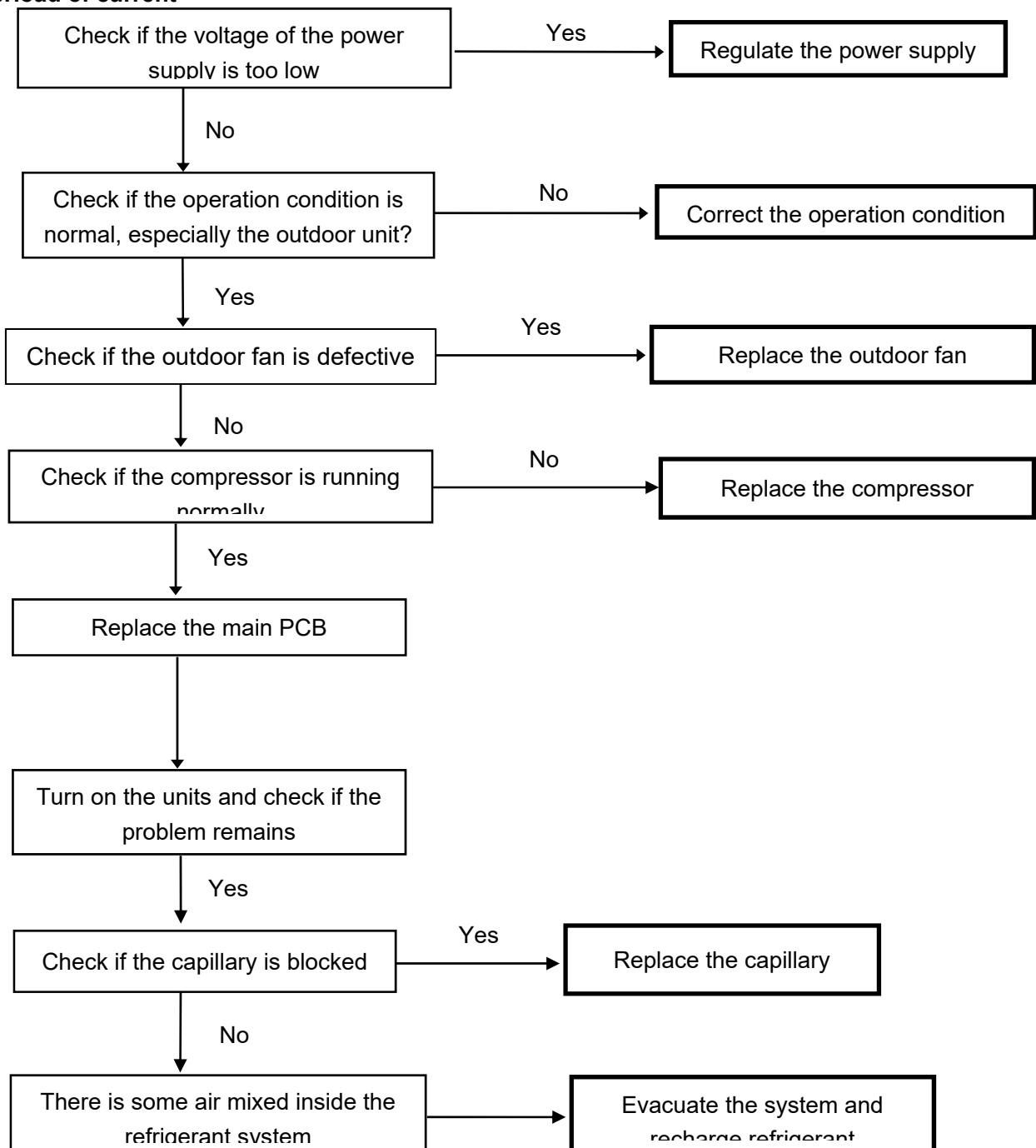
c. Overload of current

d. Protection of pressure or temp.

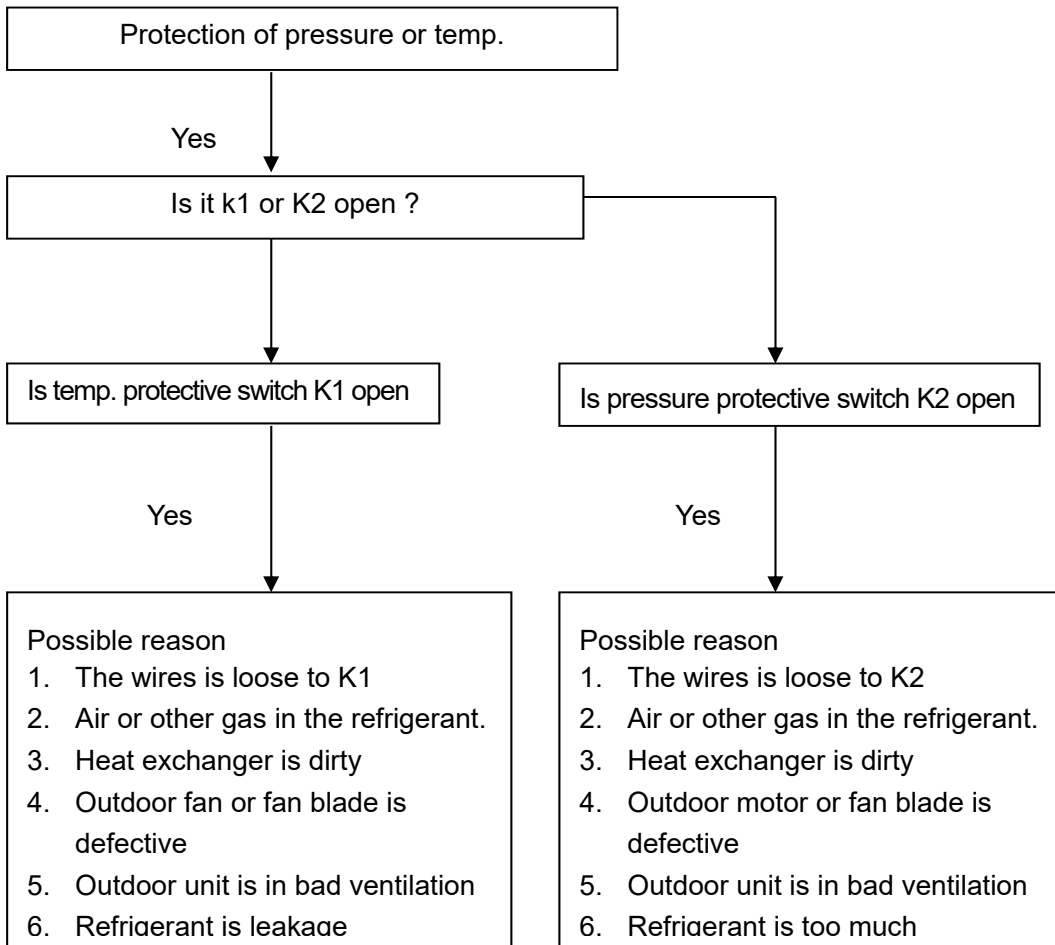

e. Temperature sensor open or short circuit

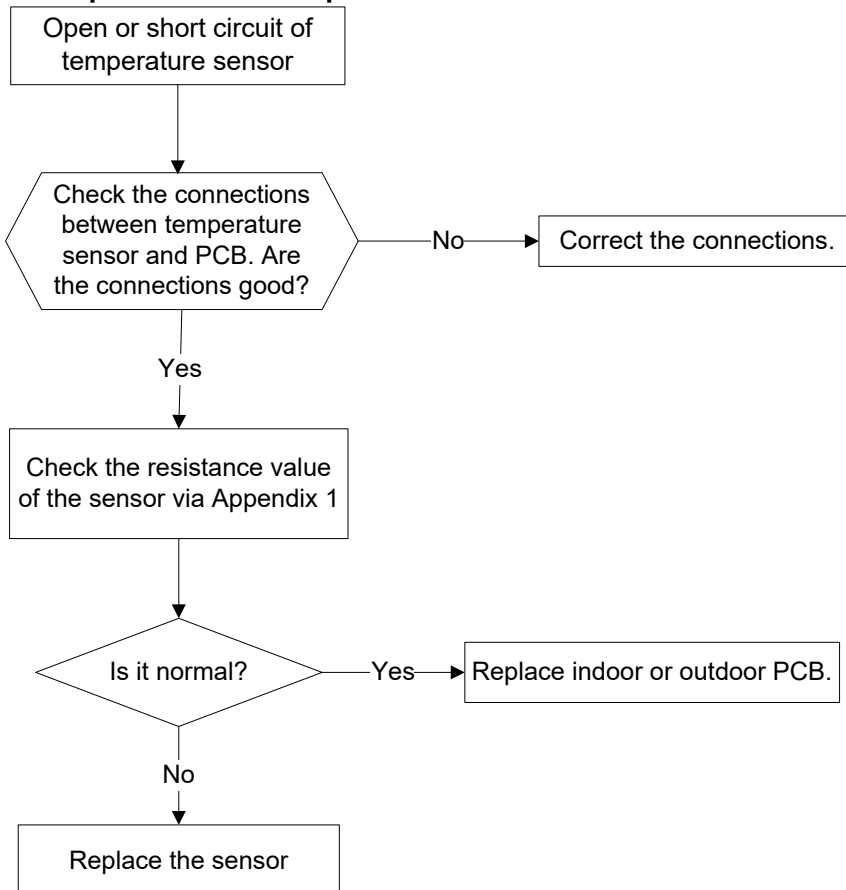

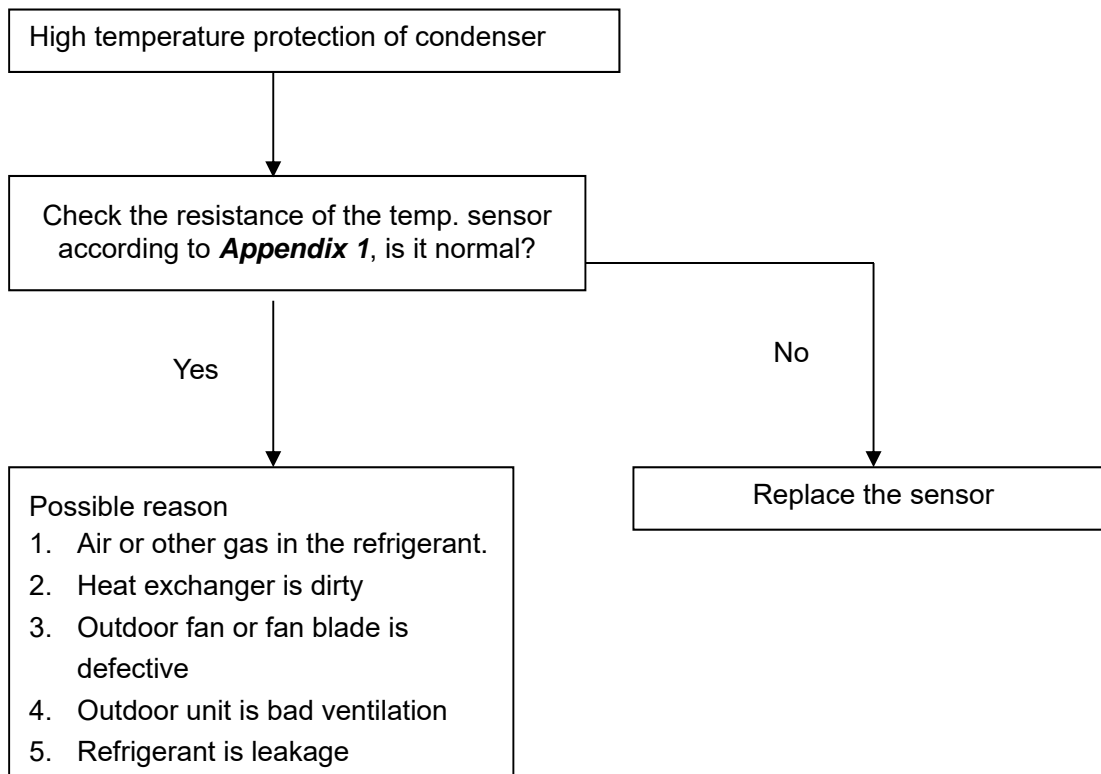
f. High temperature protection of condenser

Appendix 1 Temperature Sensor Resistance Value Table (°C--K)

°C	K Ohm	°C	K Ohm	°C	K Ohm	°C	K Ohm
-20	115.266	20	12.6431	60	2.35774	100	0.62973
-19	108.146	21	12.0561	61	2.27249	101	0.61148
-18	101.517	22	11.5000	62	2.19073	102	0.59386
-17	96.3423	23	10.9731	63	2.11241	103	0.57683
-16	89.5865	24	10.4736	64	2.03732	104	0.56038
-15	84.2190	25	10.0000	65	1.96532	105	0.54448
-14	79.3110	26	9.55074	66	1.89627	106	0.52912
-13	74.5360	27	9.12445	67	1.83003	107	0.51426
-12	70.1698	28	8.71983	68	1.76647	108	0.49989
-11	66.0898	29	8.33566	69	1.70547	109	0.48600
-10	62.2756	30	7.97078	70	1.64691	110	0.47256
-9	58.7079	31	7.62411	71	1.59068	111	0.45957
-8	56.3694	32	7.29464	72	1.53668	112	0.44699
-7	52.2438	33	6.98142	73	1.48481	113	0.43482
-6	49.3161	34	6.68355	74	1.43498	114	0.42304
-5	46.5725	35	6.40021	75	1.38703	115	0.41164
-4	44.0000	36	6.13059	76	1.34105	116	0.40060
-3	41.5878	37	5.87359	77	1.29078	117	0.38991
-2	39.8239	38	5.62961	78	1.25423	118	0.37956
-1	37.1988	39	5.39689	79	1.21330	119	0.36954
0	35.2024	40	5.17519	80	1.17393	120	0.35982
1	33.3269	41	4.96392	81	1.13604	121	0.35042
2	31.5635	42	4.76253	82	1.09958	122	0.3413
3	29.9058	43	4.57050	83	1.06448	123	0.33246
4	28.3459	44	4.38736	84	1.03069	124	0.32390
5	26.8778	45	4.21263	85	0.99815	125	0.31559
6	25.4954	46	4.04589	86	0.96681	126	0.30754
7	24.1932	47	3.88673	87	0.93662	127	0.29974
8	22.5662	48	3.73476	88	0.90753	128	0.29216
9	21.8094	49	3.58962	89	0.87950	129	0.28482
10	20.7184	50	3.45097	90	0.85248	130	0.27770
11	19.6891	51	3.31847	91	0.82643	131	0.27078
12	18.7177	52	3.19183	92	0.80132	132	0.26408
13	17.8005	53	3.07075	93	0.77709	133	0.25757
14	16.9341	54	2.95896	94	0.75373	134	0.25125
15	16.1156	55	2.84421	95	0.73119	135	0.24512
16	15.3418	56	2.73823	96	0.70944	136	0.23916
17	14.6181	57	2.63682	97	0.68844	137	0.23338
18	13.9180	58	2.53973	98	0.66818	138	0.22776
19	13.2631	59	2.44677	99	0.64862	139	0.22231

Appendix 2

Unit: °C---K				Discharge temp. sensor table			
-20	542.7	20	68.66	60	13.59	100	3.702
-19	511.9	21	65.62	61	13.11	101	3.595
-18	483	22	62.73	62	12.65	102	3.492
-17	455.9	23	59.98	63	12.21	103	3.392
-16	430.5	24	57.37	64	11.79	104	3.296
-15	406.7	25	54.89	65	11.38	105	3.203
-14	384.3	26	52.53	66	10.99	106	3.113
-13	363.3	27	50.28	67	10.61	107	3.025
-12	343.6	28	48.14	68	10.25	108	2.941
-11	325.1	29	46.11	69	9.902	109	2.86
-10	307.7	30	44.17	70	9.569	110	2.781
-9	291.3	31	42.33	71	9.248	111	2.704
-8	275.9	32	40.57	72	8.94	112	2.63
-7	261.4	33	38.89	73	8.643	113	2.559
-6	247.8	34	37.3	74	8.358	114	2.489
-5	234.9	35	35.78	75	8.084	115	2.422
-4	222.8	36	34.32	76	7.82	116	2.357
-3	211.4	37	32.94	77	7.566	117	2.294
-2	200.7	38	31.62	78	7.321	118	2.233
-1	190.5	39	30.36	79	7.086	119	2.174
0	180.9	40	29.15	80	6.859	120	2.117
1	171.9	41	28	81	6.641	121	2.061
2	163.3	42	26.9	82	6.43	122	2.007
3	155.2	43	25.86	83	6.228	123	1.955
4	147.6	44	24.85	84	6.033	124	1.905
5	140.4	45	23.89	85	5.844	125	1.856
6	133.5	46	22.89	86	5.663	126	1.808
7	127.1	47	22.1	87	5.488	127	1.762
8	121	48	21.26	88	5.32	128	1.717
9	115.2	49	20.46	89	5.157	129	1.674
10	109.8	50	19.69	90	5	130	1.632
11	104.6	51	18.96	91	4.849		
12	99.69	52	18.26	92	4.703		
13	95.05	53	17.58	93	4.562		
14	90.66	54	16.94	94	4.426		
15	86.49	55	16.32	95	4.294	B(25/50)=3950K	
16	82.54	56	15.73	96	4.167		
17	78.79	57	15.16	97	4.045	R(90°C)=5KΩ±3%	
18	75.24	58	14.62	98	3.927		
19	71.86	59	14.09	99	3.812		